

CAM424/426/428/432

Features

- ✓ Excellent picture quality 700TVL *NiteDevil* camera
- ✓ Built in heater, keeps lens clear in frosty conditions
- ✓ Special UV stabilised lens prevents discolouration
- ✓ Small compact design
- ✓ Low light capability (0.00019 lux approximately)
- ✓ No additional enclosures required
- ✓ Unique construction prevents the ingress of water to the sensitive electronics (IP67)
- ✓ Tough shock-proof resin protects against vibration damage
- ✓ Now supplied in 3.6mm, 6mm, 8mm and 12mm models



The System Q camera is built to a very high standard. With an outstanding picture quality the camera is easily connected to the Advanced-Vision Control unit. The electronics in the main camera body are sealed in an epoxy resin to give shock protection and a unique waterproofing quality that means the camera can be used outdoors without the need for any special enclosures. In the harshest of winters, the surrounding resin gently heats the lens at the front of the camera and this helps prevent any frosting on the lens down to approximately -20 degrees C. (External air temp.). Even in the sunniest of summers, the special UV stabilised lens prevents discoloration for a crystal clear image that lasts.

OPENING THE CAMERA.

The camera terminal block is contained within the camera base. To obtain access, tilt the camera head downwards and use a Philips screwdriver to reach the central retaining screw marked '2' in diagram A. Remove this screw to gain access to the back plate.

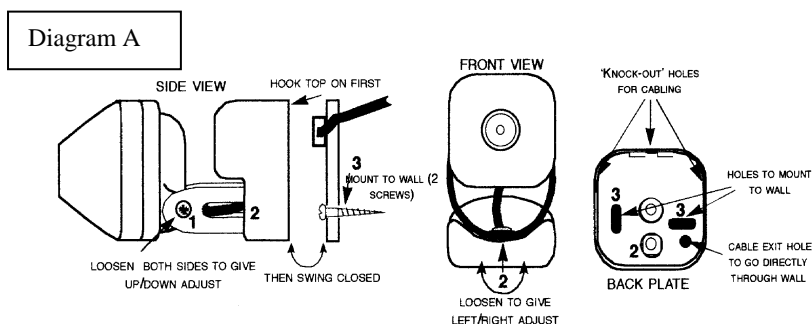

POSITIONING THE CAMERA

As with all CCD cameras, avoid directing the camera at any object or surface containing bright spots that may cause flare on the resulting camera picture. To reduce flaring, try to ensure that the camera is looking at a scene with uniform brightness and not a dark scene with one well-lit area. Otherwise the "auto iris" will become confused and the camera will "average" the picture to a dark scene and show the bright spot as a flared image. When trying

to identify a person with a CCD camera, plan the installation so that the person you are trying to identify will walk directly towards the camera. If therefore you are using a PIR to trigger the camera, position the PIR physically before the camera. This will have two advantages:

1. It will give recording equipment a time to react to obtain the desired shot.
2. The PIR will function far more accurately if positioned when a person walks past it rather than towards it.

It is for these reasons you will not find PIRs built into cameras in true professional CCTV equipment.

FASTENING THE CAMERA TO THE WALL.

The camera base has 2 holes used to fasten the camera to the wall using the appropriate screws. Cable entry can be via any of the appropriate cable "knock-outs" as indicated in diagram A

Connecting to System Q CCTV equipment.

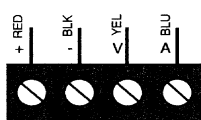

The Advanced Vision control unit and System Q camera both have colour coded terminal blocks making connection quick and easy. Simply connect Red to Red, Black to Black, Blue to Blue and Yellow to Yellow. Before installing the camera with the Advanced-Vision control unit, you must read the Advanced-Vision Control Units own instructions, which contain detailed installation notes.

Advanced-Vision Hi-Res NiteDevil Colour Camera

CONNECTING THE CAMERA TO ANY CCTV EQUIPMENT.

To do this, the camera requires a 12V 120mA **high quality regulated power supply** connected as in diagram 'C'.

Using the Video Out and OV Ground, you can connect the camera to any suitable monitor, DVR or TV using the Video-In Connector, or scart socket. On a scart socket, Video out goes to pin 20 and Video ground goes to pin 17. To see the picture on the TV you then need to switch the TV into AV mode. There is usually an AV button on the remote or try selecting Channel or button 0.

The terminals in the camera are as follow:

+ Red	+12V dc 120ma
- Black	0V D.C. / ground
V yellow	Video out @ 1V pp.
A Blue	Spare terminal for addition of an audio module

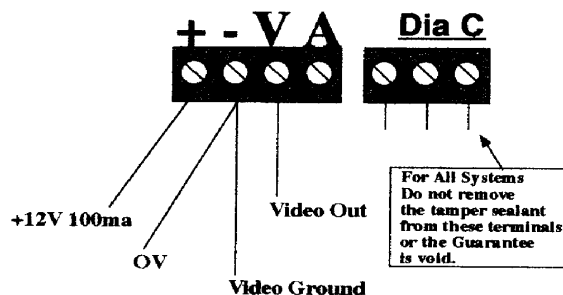

WATERPROOFING THE CAMERA The sensitive camera electronics are completely sealed and suitable for outdoor use without any further protection or enclosure. To prevent long term corrosion, it is recommended that the terminal strip in the camera base is sprayed with WD40 or similar.

The camera optics are UV stabilised to prevent image distortion after long term use.

CONDITIONS OF GUARANTEE

Because of the harsh environmental conditions our cameras are subject to, we take great steps to protect the sensitive electronics against the elements. No other camera is sealed in the same way. Once installed correctly the only fault the camera can exhibit from naturally occurring component failure, will be that of a poor or garbage output, but an output will be present. This will usually include some white in the picture.

What we can not protect against is human error

If the camera input leads are mixed up and the power is inadvertently cross connected, or even applied to the video out wire, the camera will be damaged. Depending upon what cross connection has occurred, the camera will exhibit a change of impedance that we can measure to determine how the camera became damaged. The symptoms for this damage by human error are a non-existent picture or black screen. We understand that human error is possible but advise you to take extreme caution when installing units to prevent cross connection of wires.

If you do accidentally damage a camera we will upgrade the unit for you using our competitive upgrade scheme. This obviously is a substantial saving on a new unit but charges will be levied.

All our products are covered by a guarantee valid for 12 months from the invoice date as per the conditions above. The guarantee is against defects in parts and workmanship but does not cover fair wear and tear or misuse. This guarantee is valid providing that the product has been used according to the operating instructions and has not been modified in any way by unauthorised personnel and is supplied with proof of purchase. The guarantee operates on a "return to base, repair or replace" basis.

SPECIFICATIONS

CAM404/406/412	Colour Indoor/Outdoor Camera
Element	1/3" Hi-Res Colour CCD
Lens	CAM424 3.6mm / CAM426 6mm / CAM 408 8mm / CAM432 12mm
Lens Angle	72° field of view
T.V. lines	700 TVL minimum
Min Illumination	0.00019 lux (NiteDevil mode) F2.0
Shutter speed	1/50 sec ~ 1/1000.000 sec
White Balance	Automatic
S/N Ratio	>52dB
Current Consumption	120mA
Power Voltage	12V dc
Iris Control	Electronic system
Mounting	Bracket Included
Housing	No additional enclosures needed for external use.
Size	H 40mm * W 40mm * L 40mm (80mm inc. brkt.)
IP Rating	IP67 Electronics

WARNING
Under no circumstances remove or disconnect the black 3-core cable that connects the front head of the camera to its base plate. By doing this you will void all



This symbol on the products and/or accompanying documents means that used electronic equipment must not be mixed with general household waste. For treatment, recovery and recycling please return this unit to your trade supplier or local designated collection point as defined by your local council.

WEE/CG0783SS

All specifications are approximate. Nitedevil.com reserves the right to change any product specifications or features without notice. Whilst every effort is made to ensure that these instructions are complete and accurate, nitedevil.com cannot be held responsible in any way for any losses, no matter how they arise, from errors or omissions in these instructions, or the performance or non-performance of the equipment that these instructions refer to.