



**The new DVR365 Compact DVR**  
H264 Compression – High Resolution  
Model DSD220 Series



**Operations Manual**

Version 4

# Table of Contents

<b>1</b>	<b>FEATURES AND SPECIFICATIONS .....</b>	<b>8</b>
1.1	FEATURES.....	8
1.2	SPECIFICATIONS.....	8
<b>2</b>	<b>OVERVIEW AND CONTROLS .....</b>	<b>11</b>
2.1	FRONT PANEL .....	11
2.2	REAR PANEL .....	13
2.2.1	Overview .....	13
2.2.2	Connection Sample .....	13
2.3	REMOTE CONTROL.....	14
2.4	MOUSE CONTROL.....	14
2.5	VIRTUAL KEYBOARD AND FRONT PANEL .....	16
2.5.1	Virtual Keyboard .....	16
2.5.2	Front Panel.....	16
<b>3</b>	<b>INSTALLATION AND CONNECTIONS .....</b>	<b>17</b>
3.1	CHECK UNPACKED DVR .....	17
3.2	HDD INSTALLATION .....	17
3.2.1	Choose Serial HDDs .....	17
3.2.2	Calculate HDD Size .....	17
3.2.3	HDD Installation.....	17
3.3	CD/DVD BURNER INSTALLATION.....	19
3.4	DESKTOP AND RACK MOUNTING.....	19
3.4.1	Desktop Mounting .....	19
3.4.2	Rack Mounting .....	19
3.5	CONNECTING POWER SUPPLY .....	19
3.6	CONNECTING VIDEO INPUT AND OUTPUT DEVICES .....	19
3.6.1	Connecting Video Input .....	19
3.6.2	Connecting Video Output.....	20
3.7	CONNECTING AUDIO INPUT/OUTPUT & LOOPTHROUGHS.....	21

3.7.1	Audio Input/One Audio Output .....	21
3.7.2	Looping video (available on certain 8 and 16 way DVRs only) .....	22
3.7.3	Matrix Video Output (optional) .....	22
3.7.4	Alarm Input and Relay Output .....	22
3.7.5	Alarm Input .....	22
3.7.6	Alarm Output .....	23
3.7.7	Alarm Input and Output Details .....	23
3.7.8	Relay Output Description .....	24
3.8	RS232 .....	26
3.9	RS485 .....	26
3.10	OTHER INTERFACES .....	26
<b>4</b>	<b>OVERVIEW OF NAVIGATION AND CONTROLS .....</b>	<b>28</b>
4.1	LOGIN, LOGOUT & MAIN MENU .....	28
4.1.1	Login .....	28
4.1.2	Main Menu .....	28
4.1.3	Logout .....	29
4.1.4	Auto Resume after Power Failure .....	29
4.1.5	Replace Button Battery (If DVR loses time or will not display correct date/time) .....	29
4.2	RECORDING OPERATION .....	30
4.2.1	Live Viewing .....	30
4.2.2	Manual record .....	30
4.3	SEARCH & PLAYBACK .....	32
4.3.1	Search Menu .....	32
4.3.2	Basic Operation .....	33
4.3.3	Calendar .....	35
4.4	RECORD SETUP (SCHEDULE) .....	36
4.4.1	Schedule Menu .....	36
4.4.2	Basic Operation .....	36
4.5	DETECT .....	38
4.5.1	Go to Motion Detect Menu .....	38
4.5.2	Motion Detect .....	38
4.5.3	Video Loss .....	41
4.5.4	Camera Masking .....	41
4.6	ALARM SETUP AND ALARM ACTIVATION .....	42
4.7	BACKUP .....	44

4.8	PTZ CONTROL AND COLOUR SETUP .....	45
4.8.1	Cable Connection .....	45
4.8.2	PTZ Setup.....	45
4.9	PRESET/ PATROL/PATTERN/SCAN .....	46
4.9.1	Preset Setup.....	47
4.9.2	Activate Preset.....	47
4.9.3	Patrol setup (Tour Setup) .....	47
4.9.4	Activate Patrol (tour) .....	47
4.9.5	Pattern Setup.....	47
4.9.6	Activate Pattern Function.....	48
4.9.7	Auto Scan Setup .....	48
4.9.8	Activate Auto Scan.....	48
<b>5</b>	<b>MENU OPERATIONS AND CONTROLS.....</b>	<b>49</b>
5.1	MENU TREE.....	49
5.2	MAIN MENU.....	49
5.3	SETTING.....	50
5.3.1	General .....	50
5.3.2	Encode.....	51
5.3.3	Schedule .....	51
5.3.4	RS232.....	51
5.3.5	Network.....	52
5.3.6	Alarm.....	59
5.3.7	Detect .....	59
5.3.8	Pan/Tilt/Zoom.....	59
5.3.9	Display .....	60
5.3.10	Default.....	61
5.4	SEARCH.....	61
5.5	ADVANCED.....	61
5.5.1	HDD Management .....	62
5.5.2	Alarm Output.....	63
5.5.3	Alarm Input .....	63
5.5.4	Manual Record.....	63
5.5.5	Account .....	63
5.5.6	Auto Maintain.....	64
5.5.7	TV Adjust.....	64
5.5.8	Video Matrix (Optional).....	65
5.6	INFORMATION .....	69
5.6.1	HDD Information.....	69

5.6.2	BPS.....	70
5.6.3	Log .....	70
5.6.4	Version .....	70
5.6.5	Online Users .....	71
5.7	EXIT .....	71
<b>6</b>	<b>ABOUT AUXILIARY MENU .....</b>	<b>72</b>
6.1	GO TO PAN/TILT/ZOOM MENU .....	72
6.1.1	3D Intelligent Positioning Key .....	73
6.2	PRESET /PATROL / PATTERN /BORDER FUNCTION.....	73
6.2.1	Preset Setup .....	74
6.2.2	Activate Preset.....	74
6.2.3	Patrol Setup .....	74
6.2.4	Activate Patrol .....	74
6.2.5	Pattern Setup.....	74
6.2.6	Activate Pattern Function.....	74
6.2.7	Border Setup.....	75
6.2.8	Activate Border Function .....	75
<b>7</b>	<b>WEB CLIENT OPERATION .....</b>	<b>76</b>
7.1	NETWORK CONNECTION .....	76
7.2	LOGIN AND LOGOUT .....	76
<b>8</b>	<b>SIGHTBOSS SYSTEM.....</b>	<b>103</b>
8.1	FEATURES.....	103
8.2	ENVIRONMENT.....	103
8.3	OVERVIEW.....	103
8.4	MORE DETAILS.....	104
<b>9</b>	<b>FREQUENTLY ASKED QUESTIONS .....</b>	<b>105</b>
<b>11</b>	<b>NETWORKING A DIGITAL VIDEO RECORDER.....</b>	<b>109</b>
11.1	BASIC NETWORK TROUBLESHOOTING .....	109
11.2.1	OPTION 1 : CONNECT A DVR DIRECTLY TO A SINGLE PC .....	112
11.2.2	OPTION 2 : CONNECT A DVR TO A PC VIA A SWITCH OR HUB.....	113
11.2.3	OPTION 3 : CONNECTING FOR INTERNET ACCESS.....	114
<b>APPENDIX A</b>	<b>HDD CAPACITY CALCULATION .....</b>	<b>116</b>

## **Welcome**

Thank you for purchasing our DVR!

This operating manual is designed to be a reference tool for the installation and operation of your system.

Here you can find information about this series DVR features and functions, as well as a detailed menu tree.

Before installation and operation please read the following safeguards and warnings carefully!

## **Important Safeguards and Warnings**

### **1 . Electrical safety**

The installation and operation of this DVR must conform to UK electrical safety standards. We accept no liability or responsibility for problems caused by improper handling or installation.

### **2 . Transportation Security and Installation**

Ensure that during transportation and installation of this equipment that the DVR is not subject to vibration, dampness or mishandling.

### **3 . Installation**

Keep upright and handle with care.

Do not apply power to the DVR before completing installation.

Do not place objects on top of the DVR or near any air vents.

### **4 . Qualified engineers needed**

All examination and repair work must be undertaken by a qualified service engineer.

We are not liable for any problems caused by unauthorised modifications or repairs.

### **5 . Environment**

The DVR should be installed in a cool, dry place, away from direct sunlight and any inflammable or explosive substances etc.

## **6. Accessories**

Only use accessories recommended by the manufacturer.

Before installation, please open the package and check all the components listed below are included:

- One power cable
- One Ethernet cable
- Four HDD cables
- Alarm & relay terminal blocks
- Extensional cable (for audio, loop & matrix)
- One remote control (including the battery)
- One USB mouse
- One CD (including DVR manual and Client software)
- A package of installation fittings

# 1 Features and Specifications

## 1.1 Features

This series DVR has the following features:

- H.264 compression algorithm.
- Real-time live display up to 16 cameras, up to 400fps recording for CIF. Note fps relates to 16 channel model.
- Pentaplex function: live, recording, playback, backup & remote access
- Intelligent search and playback support. You can playback motion detection video that occurs in an area you select.
- 4 HDDs supported and CD-RW/DVD-RW.
- Multiple control methods: front panel, IR remote control, keyboard, USB mouse and network keyboard.
- Smart video detection: motion detection, camera masking and video loss.
- Smart camera settings: privacy masking, camera lock, colour setting, and title display.
- Pan Tilt Zoom and Speed Dome Control: more than 60 protocols supported, preset, scan, auto pan, auto tour, pattern and auxiliary functions.
- Easy backup methods: USB, CD-RW/DVD-RW and network download
- Alarm triggering screen tips, buzzer, PTZ preset, e-mail, FTP upload.
- Smart HDD Management: HDD hibernation, HDD faulty alarm and Raid functionality.
- Powerful network software: built-in web server, EPSS. Networking access for remote live viewing, recording, playback, setting, system status, event log, e-mail and FTP function.
- Dual encoding stream support; flexible for network transmission.

## 1.2 Specifications

### Models

DSD200 Series            4/8/16 channel models

### System

Main Processor            High performance embedded microprocessor

Operating System        Embedded LINUX

System Resources        Pentaplex function: live, recording, playback, backup & remote access

User Interface            GUI, on-screen menu tips.

Control Device            Front panel, USB mouse, keyboard, IR remote control, network keyboard,.

Input Method             Numeral/Character/Denotation

System Status            HDD status, data stream statistics, log record, bios version, on-line user and etc.

### Video

Video Input                4/8/16 Channel, BNC, 1.0Vp-p, 75Ω, looping(optional),

Video Output              2-channel TV output BNC, 1.0Vp- p, 75Ω,1 VGA output, matrix output (optional)



Video Standards	PAL ( 625Line , 50f/s ) , NTSC ( 525Line , 60f/s )		
Video Compression	H.264		
Video Resolution	Format	NTSC	PAL
	CIF	352 * 240	352 * 288
Video Recording	CIF: PAL 1f/s-25f/s NTSC 1f/s-30f/s		
Video Display Split	Full and multiple screen display, 1 / 4 / 8 / 9 / 16 (Models vary)		
Tour Display	Provided		
Image Quality	1~6 level (level 6 is the best but will use more HDD space)		
Privacy Masking	Self-defined four-sided zone for privacy masking for each camera		
Camera Lock	Camera lock facility		
Camera Adjustment	Adjust colour according to different time periods		
Video Information	Camera title, time, video loss, camera lock, motion detection and recording		
TV Output Adjustment	Adjust TV output colour & display zone		
<b>Audio</b>			
Audio Input	4/8/16 channel, BNC, 200-2800mV, 30K $\Omega$		
bidirectional Audio Input	1-channel, RCA, 200-2800mV, 30K $\Omega$		
Audio Output	1-channel, RCA, 200-3000mv, 5K $\Omega$		
Audio Compression	ADPCM		
<b>Video Detection &amp; Alarm</b>			
Motion Detection	Zones: 192 (16*12) detection zones Sensitivity: 1~6 (level 6 is highest) Trigger recording, PTZ movement, tour, alarm & FTP		
Video Loss	Trigger recording, PTZ movement, tour, alarm & FTP		
Camera masking	Trigger recording, PTZ movement, tour, alarm & FTP		
Alarm Input	4/8/16 channel, programmable, ground, manual open/closed Trigger recording, PTZ movement, tour, alarm & FTP		
Relay output	3/6/6-channel, 30VDC, 1A, NO/NC, form-C		
<b>Hard Disk</b>			
Hard Disk	4 SATA ports, 4 HDDs supported.		
Space Occupation	Audio : 14.4MB/H Video : 56 ~ 400MB/H		
HDD Management	Hard disk hibernation technology, HDD faulty alarm & Raid (Redundancy)		
<b>Record, Playback &amp; Backup</b>			
Recording Mode	Manual, continuous, video detection (including motion detection, camera masking, video loss), Alarm		
Recording Priority	Manual > Alarm > Video Detection > Continuous.		
Recording Interval	1 to 120 minutes (default: 60 minutes)		
Overwrite Mode	Provided		
Raid Function	Provided		
Search Mode	Time/Date, Alarm, Motion Detection & exact search (accurate to one second)		

Playback	1-channel playback. Play, pause, stop, rewind, fast play, slow play, next file, previous file, next camera, previous camera, full screen, repeat, shuffle & backup selection.
Digital Zoom	Selected zone can zoom into full screen during playback
Backup Mode	Memory stick/ USB HDD/ USB CD-RW/DVD-RW/ built-in SATA Burner/ network download
<b>Network</b>	
Interface	RJ-45 Port (10/100M)
Network Functions	TCP/IP, DHCP, DDNS, PPPoE, E-mail, FTP
Remote operation	Monitor, PTZ control, playback, system setting, file download, log information
<b>Auxiliary Interface</b>	
USB Interface	2 USB 2.0 ports, 1 for mouse control, 1 for backup.
RS232	Keyboard, PC communication
RS485	PTZ control
<b>Environmental</b>	
Power Supply	220V 50Hz / 110V 60Hz
Power Consumption	25W/30W/40W (4ch/8ch/16ch)
Working Temperature	-10°C~ + 55°C
Power Consumption	25W/30W/40W (4ch/8ch/16ch)
Working Humidity	10%~90%
Atmosphere Pressure	86kpa~106kpa
Dimension	1.5U, 440mmx460mmx68mm (W*D*H)
Weight	6.0KG
Mounting	Desktop or rack

## 2 Overview and Controls

This section provides information about front panel and rear panel. When you install this series DVR for the first time, please refer to this part first.

### 2.1 Front Panel

This series DVR front panel is shown as in Figure 2-1 .

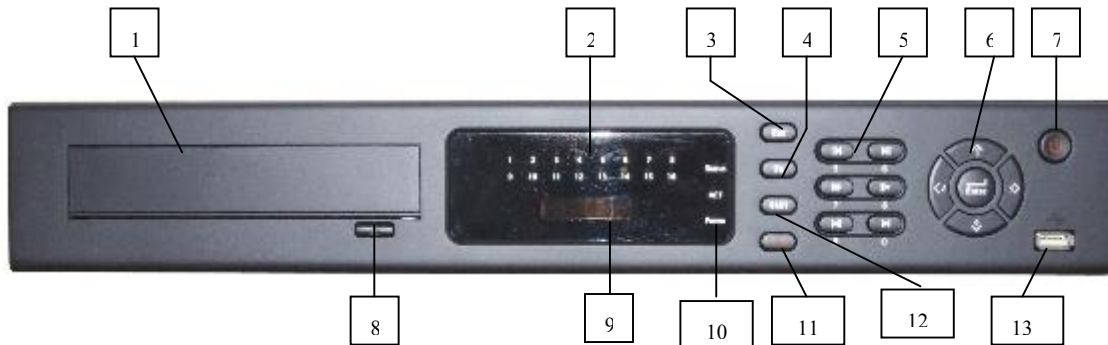

Figure 2-1

Ref	Type	Identifier	Function
1	DVD Writer	CD/DVD-R	Backup device
2	Recording Channels	Display	Channels recording
3	Escape button	ESC	Exiting from menus
4	Function button	Fn	Press to enter function
5	Dual function keys	Speed/Numeric keys	Select speed/numerics 5-9,0
6	Tri-functional keys	Direction/Numeric/Enter keys	Select direction/numerics 1-4, Enter functions
7	Power button	Power On/Off	Switch power on or off
8	Writer Tray button	Writer tray open and close	Press to enter CD/DVD media
9	Time	Display	Time display
10	LEDs	Status, ACT and Power	DVR functions
11	Record button	REC	Manual record button
12	Shift button	Shift	Shift function
13	USB connection	USB connector	USB 2 input for mouse



## 2.2 Rear Panel

### 2.2.1 Overview

Please refer to Figure 2-1 for information.

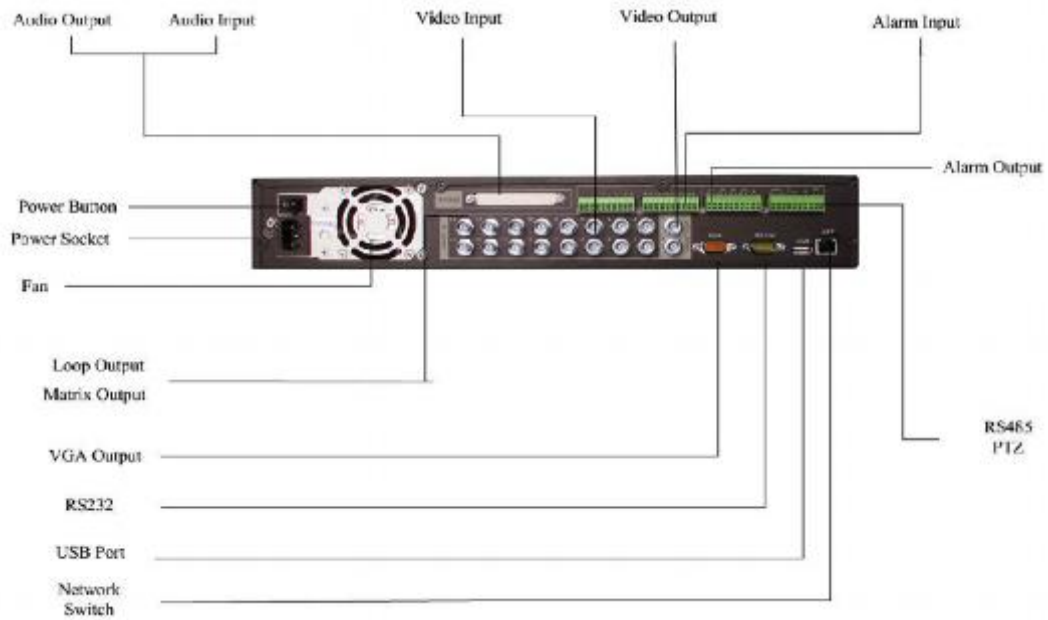

Figure 2-1

### 2.2.2 Connection Sample

Here is a connection sample for your reference. See Figure 2-2.

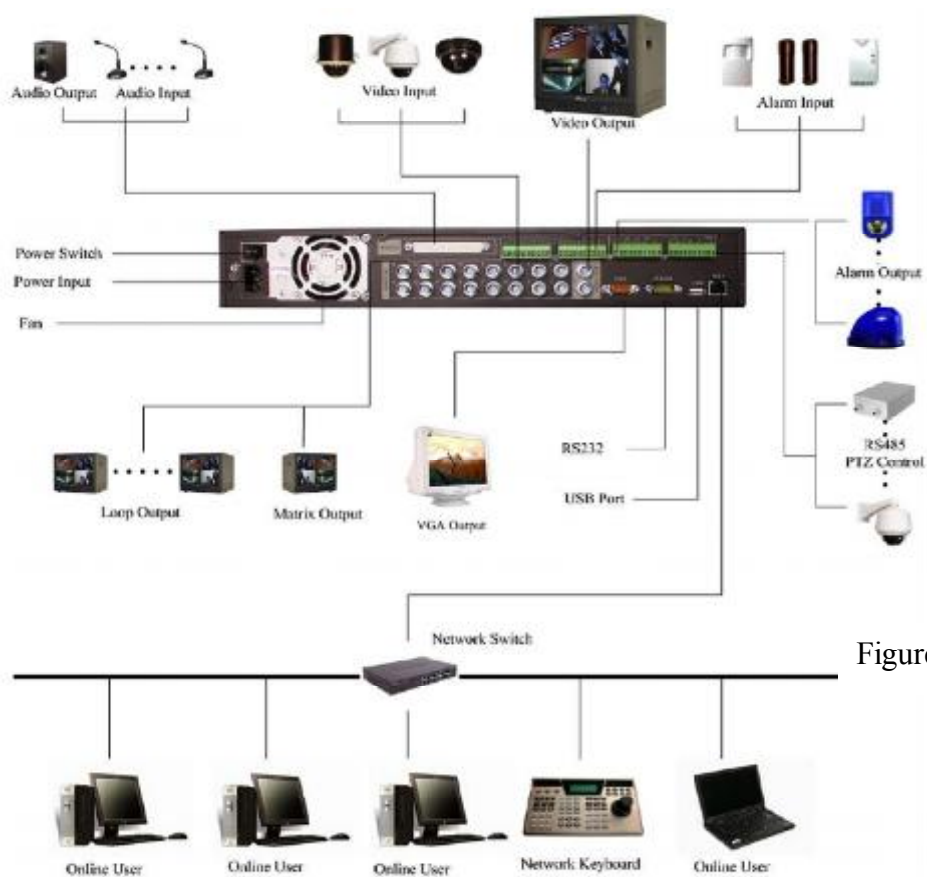

Figure 2-4

## 2.3 Remote Control

The remote control interface is shown as in Figure 2-3.

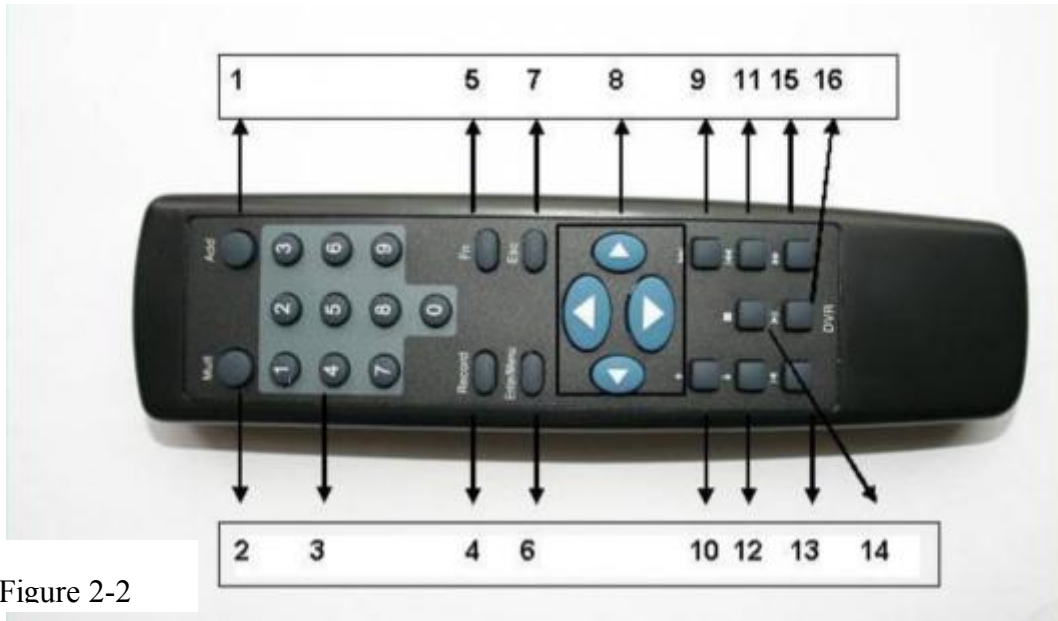



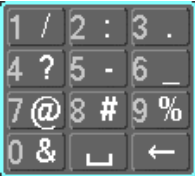

Figure 2-2

Figure 2-3

Serial Number	Function
1	Remote switch
2	Multiple-window switch
3	0-9 number key
4	Record
5	Auxiliary key
6	Confirm /menu key
7	Cancel
8	Direction key
9	Forward
10	Previous
11	Back
12	Next
13	Slow play
14	Stop
15	Fast play
16	Play/Pause

## 2.4 Mouse Control

Left click mouse	System displays password input box if you have not logged in.
	In real-time monitor mode, you can go to the main menu.
	When you have selected one menu item, left click mouse to view menu content.
	Implement the control operation.
	Modify checkbox or motion detection status.
	Click combo box to display drop down list

	<p>In the input box you can select various input methods. If you left click the corresponding button on the panel you can input numerals, upper and lower case letters or symbols. The arrow ← stands for backspace button and the underline _ stands for the space button.</p> <p><b>In text mode:</b> The _ stands for inputting a backspace and the ← stands for deleting the previous character.</p> <div style="display: flex; justify-content: space-around; align-items: center;">   </div> <p><b>In numeral input mode:</b> The _ stands for clear and the ← stands for deleting the previous numeral.</p> <p>When inputting a special symbol, you can click corresponding numeral in the front panel to input. For example, click numeral 1 you can input“/”, or you can click the numeral in the on-screen keyboard directly.</p> 
<p>Double left mouse click</p>	<p>Implement special control operation such as double click one item in the file list to playback the video.</p> <p>In multiple-window mode, double left click one channel to view in full-window.</p> <p>Double left click current video again to go back to previous multiple-window mode.</p>
<p>Right click mouse</p>	<p>In real-time monitor mode, the shortcut menu is displayed: One-window, Four-windows, Nine-windows and Sixteen-windows, Pan/Tilt/Zoom, Colour setting, Search, Record, Alarm output, Alarm input and Main menu.</p> <p>The Pan/Tilt/Zoom and Colour setting applies for current selected channel.</p> <p>If you are in multiple-window mode, system automatically switches to the corresponding channel.</p> 
	<p>Exit current menu without saving the modification.</p>

Press middle button	In numeral input box: Increase or decrease numeral value.
	Switch the items in the check box.
	Page up or page down
Move mouse	Select current control or move control
Drag mouse	Select motion detection zone
	Select privacy mask zone.

## 2.5 Virtual Keyboard and Front Panel

### 2.5.1 Virtual Keyboard

The system supports two input methods: numeral input and upper and lower case letter input. Move the cursor to the text column. The text is shown as blue and input button is displayed to the right. Click that button to switch between numeral input and upper/lower case letters. Use > or < to shift between lower and upper case characters.

### 2.5.2 Front Panel

Move the cursor to the text column. Click Fn key and use direction keys to select number you want. Please click enter button to input.



## 3 Installation and Connections

### 3.1 Check Unpacked DVR

Please ensure the DVR is unpacked and complete on receipt and that there is no visible damage. The carriers will not accept responsibility for any damage unless reported within 24 hours of receipt and accompanied by the delivery reference number. Note that when receiving damaged goods the customer should sign the carrier's delivery note as "Damaged" or "Not Checked" if not checked immediately.

### 3.2 HDD Installation

#### 3.2.1 Choose Serial HDDs

We recommend Seagate HDD of 7200rpm or higher.

#### 3.2.2 Calculate HDD Size

This series have no limit to HDD capacity. You can use 120Gb -750Gb HDD to guarantee higher stability.

The formula for calculating total HDD size is:

Total Capacity (Mb) = Camera Amount \* Recording Hours \* HDD Usage Per Hour (M/h)

H.264 compression is ideal for standalone DVRs. It can save more than 30% HDD capacity than standard MPEG4. When you calculate the total HD capacity, you should estimate the average HDD capacity per hour for each channel.

For example, for a 4-ch DVR, the average capacity of HDD usage per hour per channel is 200M/h. If the DVR records video for 12 hours each day for 30 days, the total capacity of HDDs required for 4 channels will be 4 channels \* 30 days \* 12 hours \* 200 M/h = 288Gb. So you need to install one 300Gb HDD or 2 x 160Gb HDDs.

#### 3.2.3 HDD Installation

Data ribbons, fastening screws and smart HDD shelf design are already provided in the accessories.

Please follow the instructions below to install hard disk.



1. Dismantle the screws from the front and rear panels.

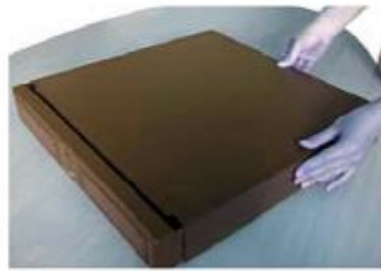

2. Remove the upper cover



3. Unfasten the HDD power cable.



4. Connect to data connection cable and then plug in the HDD power cable.



5. Fixing the HDD in the DVR.

**When installing HDD, please keep the side of the screw holes face down.**



6. Place the upper cover back on and screw down firmly .

After HDD installation, please check connection of data ribbon and power cord.

### **3.3 CD/DVD Burner Installation**

For built-in burner, you can dismantle front plate to install CD burner. This built-in burner should be a USB serial burner.

### **3.4 Desktop and Rack Mounting**

#### **3.4.1 Desktop Mounting**

To prevent surface damage, please make sure that the rubber feet are securely installed on the four corners of the bottom of the unit.

Position the unit to allow for cable and power cord clearance at the rear of the unit. Be sure that the air flow around the unit is not obstructed.

#### **3.4.2 Rack Mounting**

The DVR occupies two rack units of vertical rack space.

The hardware necessary to mount the DVR into a rack is supplied with the unit.

Rear doors may be used only on rack columns that are more than 26 inches (66.0 cm) deep.

Install the cabinet in a ventilated place. Avoid extreme heat, humid or dusty conditions. You should regularly use a soft dry brush to clean opening outlet and cooling fan etc.

### **3.5 Connecting Power Supply**

Please check that input voltage and device power button match.

We recommend you use a UPS to guarantee stable operation, DVR life span and support other peripheral equipment such as cameras.

### **3.6 Connecting Video Input and Output Devices**

#### **3.6.1 Connecting Video Input**

The DVR automatically detects the video standard (PAL or NTSC) whenever you connect a video input. It accepts both colour and black-and-white, and analog video.

NOTE:

- Enabling line lock on cameras may cause video distortion. There may be noise in the camera's power source. If video from one or more cameras is distorted, we recommend you disable line lock on the camera as your first troubleshooting step.
- If a video distribution amplifier is installed between the video source and the DVR, do not set the output video level above 1 Vp-p.

To connect each video input:

1. Connect a coaxial cable to the camera or other analog video source.
2. Connect the coaxial cable to the video in connector on the rear panel.

Please refer to Figure 3-1 for more information.

**NOTE:**

You need to use a BNC installation tool to connect coaxial cables to the rear panel.

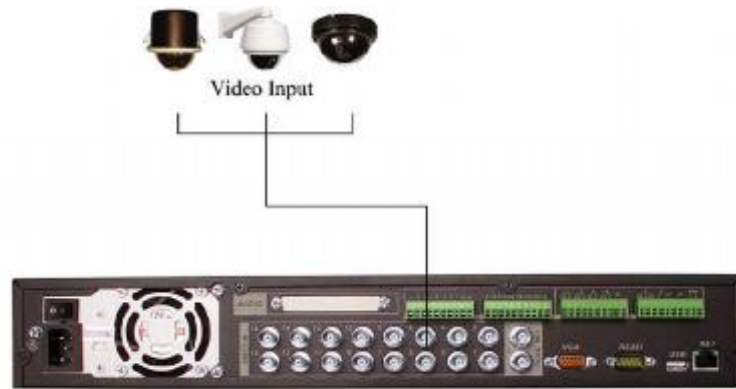

Figure 3-1

### 3.6.2 Connecting Video Output

This section provides information about physically connecting video display devices to the DVR. See Figure 3-2.

If you connect the DVR with a TV monitor or VGA monitor, the DVR can automatically detect the monitor type. Without any output device, by default, the DVR is configured to use a TV monitor. In this case, if your application requires a VGA monitor, you have to press the button “FN” or Shift on the front panel.

**NOTE:**

Video output 1 and VGA can't display at the same time. But Video output 2 can display properly with Video Output 1 or VGA.

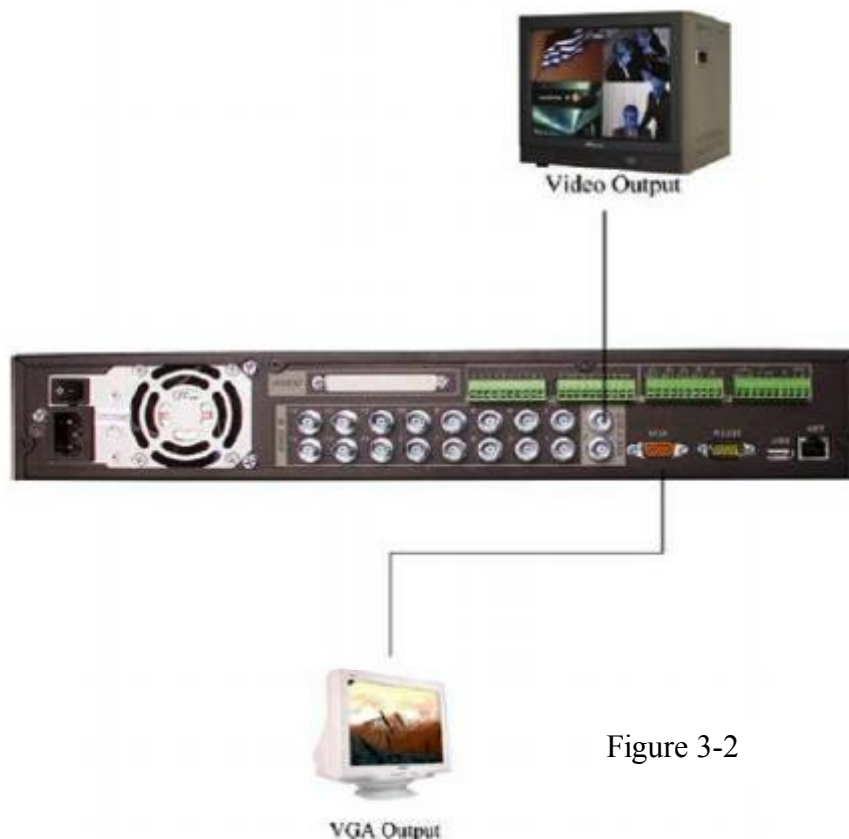

Figure 3-2

### 3.7 Connecting Audio Input/Output & Loophroughs

For the 25-pin or 37-pin interface, different models include different functions. For example, DSD224 has 4-channel audio inputs, 1 audio output, 1 bidirectional audio input. See Figure 3-3.

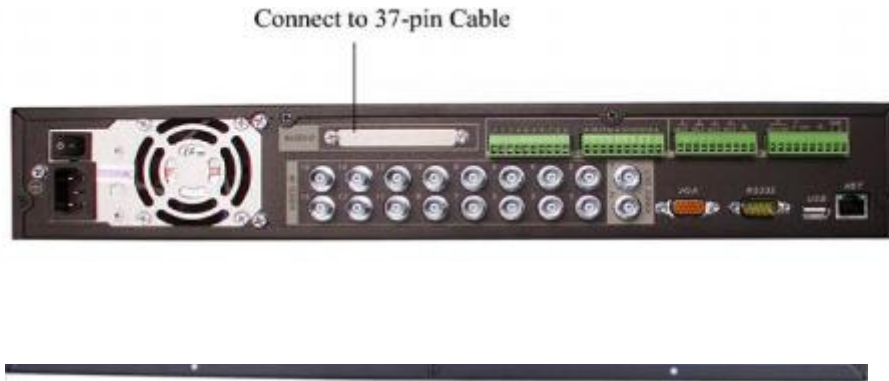

Figure 3-3

#### 3.7.1 Audio Input/One Audio Output

The DSD226 has 16 looping video inputs, 1 matrix video output, 4 audio inputs, a bidirectional audio input and 1 audio output.

##### Audio input, bidirectional audio input and audio output

The DVR encodes audio and video signals simultaneously, which lets you control audio at the monitored location.

##### To set up audio:

1. Make sure your audio input device matches the RCA input level. If the device and RCA input levels do not match, audio distortion problems may occur.
2. Make sure the audio connector is wired as follows:

Connect a line input device or pre-amplified microphone to the audio connector for the video channel on the rear panel.

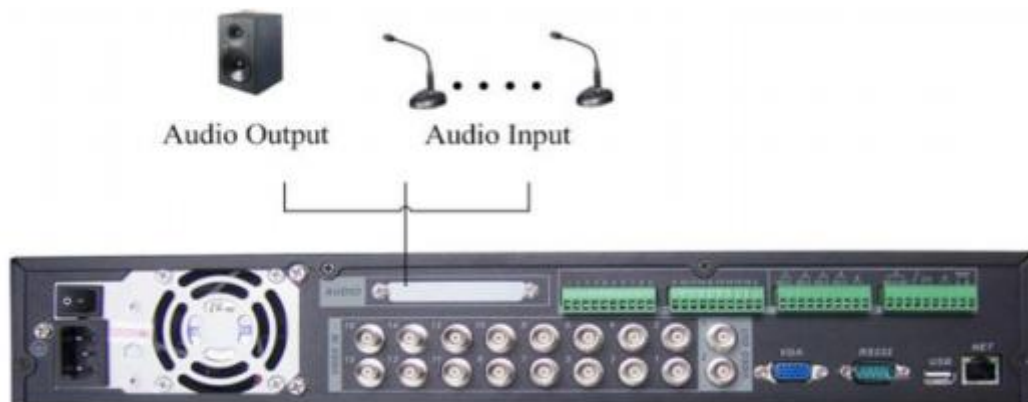

Figure 3-4

### 3.7.2 Looping video (available on certain 8 and 16 way DVRs only)

Certain DVRs support looping video. It passes the video input to a monitor or other analog video device.

#### To use looping video:

1. Connect a coaxial cable to the video out connector on 37-pin interface.(not on 25 pin)  
Please note you need to use a BNC connection on coaxial cables to the rear panel.
2. Connect the other end of the coaxial cable to the analog device.

### 3.7.3 Matrix Video Output (optional)

Use video matrix output connector during installation to display video sequentially from each video input. The unit displays each channel for selected seconds. You can use this feature to verify camera installation.

To display video from each connected video source:

1. Connect a video monitor to the video matrix output connector.
2. Turn the DVR on, the monitor, and each video matrix output source.
3. Verify the video from each source and troubleshoot as necessary.

Please refer to Figure 3-5.

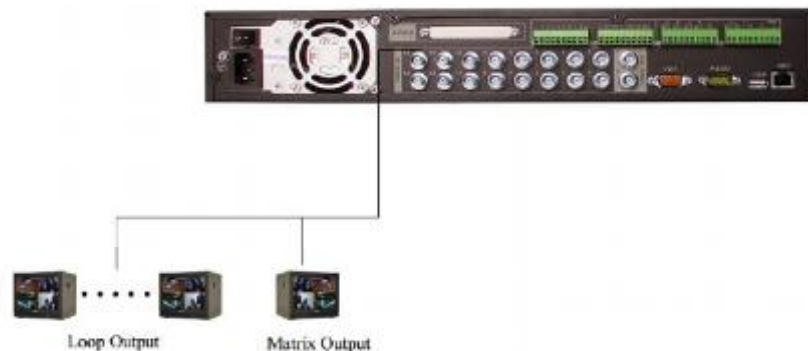

Figure 3-5

### 3.7.4 Alarm Input and Relay Output

The DVR offers 4/8/16 alarm inputs for external signaling devices, such as door contacts or motion detectors. Each alarm input can be either normally open or normally closed. Once configured, an alarm input can invoke many different activities, including triggering a relay device, sending an alert to a security office or storing pre-alarm video to the DVR.

### 3.7.5 Alarm Input

You should check whether your alarm input mode is a grounding alarm input or not.

For this series DVR, grounding signal is needed for alarm input.

If you need to connect two units or one DVR and other device, please use relay to separate them.

Please refer to Figure 3-6 for more information.



Figure 3-6

### 3.7.6 Alarm Output

Do not connect alarm output port directly to a high power load (no more than 1 A). You can use the lower green terminal block to make the connection between the alarm output port and the load. Please refer to Figure 3- for more information.

Figure 3-7



### 3.7.7 Alarm Input and Output Details

You can refer to the following sheet and Figure 3-8 for alarm input and output information.

Parameter	Grounding Alarm
Ground	Ground line
Alarm Input	1, 2, ..., 16
Relay Output	1,2,3,4: NO and C(Normally Open and Com) 5: NO,C and NC(Normally Open, Com, Normally Closed) 6: Ctrl 12V(This is used to reset the sensor)
485 A、 B	RS485 communication port. They are used to control devices such as PTZ.
+12 ( C )	This should input an external power input.



# IN

# OUT



Figure 3-8

- 4/8/16-ch grounding alarm inputs. (Normal open or Normal close type)
- Please parallel connect COM end and GND end of the alarm detector (Provide external power to the alarm detector).
- Please parallel connect the Ground of the DVR and the ground of the alarm detector.
- Please connect the NC port of the alarm sensor to the DVR alarm input (ALARM)
- If you need to reset the triggered alarm remotely, you can use DVR to supply controllable 12 V power to the alarm detector such as the smoke detector.
- Use the same ground with that of DVR if you use external power to the alarm device.

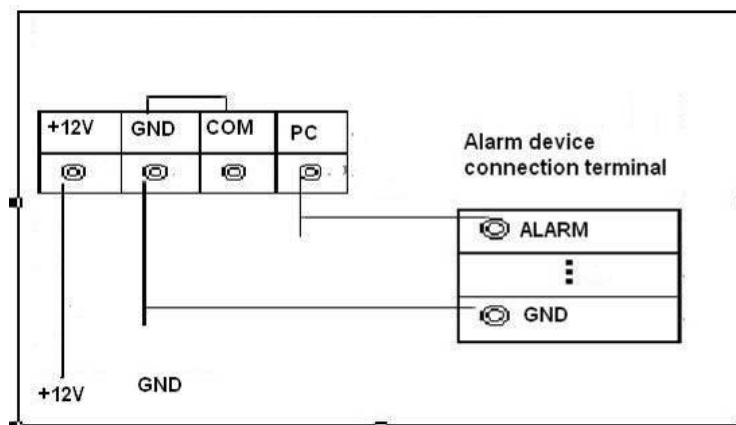

Figure 3-9

### 3.7.8 Relay Output Description

- 3/6/6 way relay alarm output. Provide external power to external alarm device.
- To avoid over loading, please read the following relay parameter sheet carefully. (See table below)
- The controllable +12v can be used to restore the smoke detector.

Please refer to Figure 3-10 for alarm input module information.



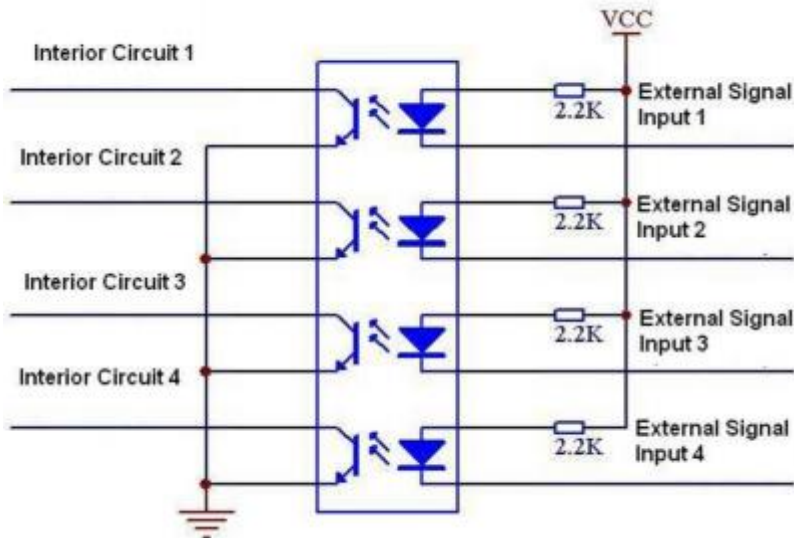

Figure 3-10

Please refer to Figure 3-11 for alarm output module information.

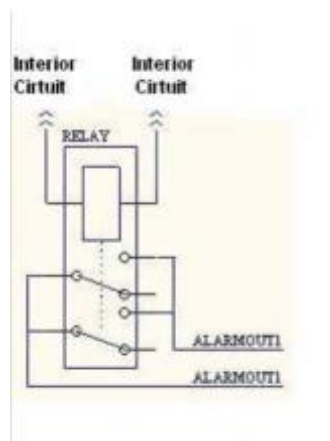

Figure 3-11

### Relay Specification

<b>Model:</b>	<b>JRC-27F</b>	
Relay contacts	Silver	
Rating ( resistance load )	Rated switch capacity	30VDC 2A, 125VAC 1A
	Maximum switch power	125VA 160W
	Maximum switch voltage	250VAC, 220VDC
	Maximum switch currency	1A
Insulation	between contacts with same polarity	1000VAC 1minute
	between contacts with different polarity	1000VAC 1minute

	between contact and winding	1000VAC 1minute 50/60Hz
Surge voltage	between contacts with same polarity	1500V (10×160us)
Length of open time	3ms max	
Length of close time	3ms max	
Longevity	Mechanical	50×10 <sup>6</sup> times (3Hz)
	Electrical	200×10 <sup>3</sup> times (0.5Hz)
Temperature	-40 ~+70	

### 3.8 RS232

PLEASE NOTE THAT RS232 IS NOT SUPPORTED.

You can connect the DVR with POS or Keyboard through RS232.

With POS system, the DVR can communicate through RS232 and network. For the POS system, the DVR can integrate the text content and even search the record through the info. This series DVR also support NKB operation. You can operate the DVR from the keyboard controls instead of using the control pad on the front panel of the unit.

To connect a NKB keyboard to the DVR:

1. Assemble the KBD keyboard according to the instructions in its accompanying installation manual.
2. Connect the KBD keyboard into one of the RS232 ports on the DVR or through network.

### 3.9 RS485

When the DVR receives a camera control command, it transmits that command up the coaxial cable to the PTZ device. RS485 is a single-direction protocol; the PTZ device can't return any data to the unit. To enable the operation, connect the PTZ device to the RS485(A,B) input on the DVR. Since RS485 is disabled by default for each camera, you must enable the PTZ settings first. This series DVR supports multiple protocols such as Pelco-D, Pelco-P etc.

#### Connecting PTZ devices to the DVR:

1. Connect RS485 A,B on the DVR rear panel.
2. Connect the other end of the cable to the RS485 connections on the camera.
3. Follow the instructions for configuring a camera to enable each PTZ device on the DVR.

### 3.10 Other Interfaces

There are other interfaces on the DVR, such as USB ports. Refer to Figure 3-12 for more information.

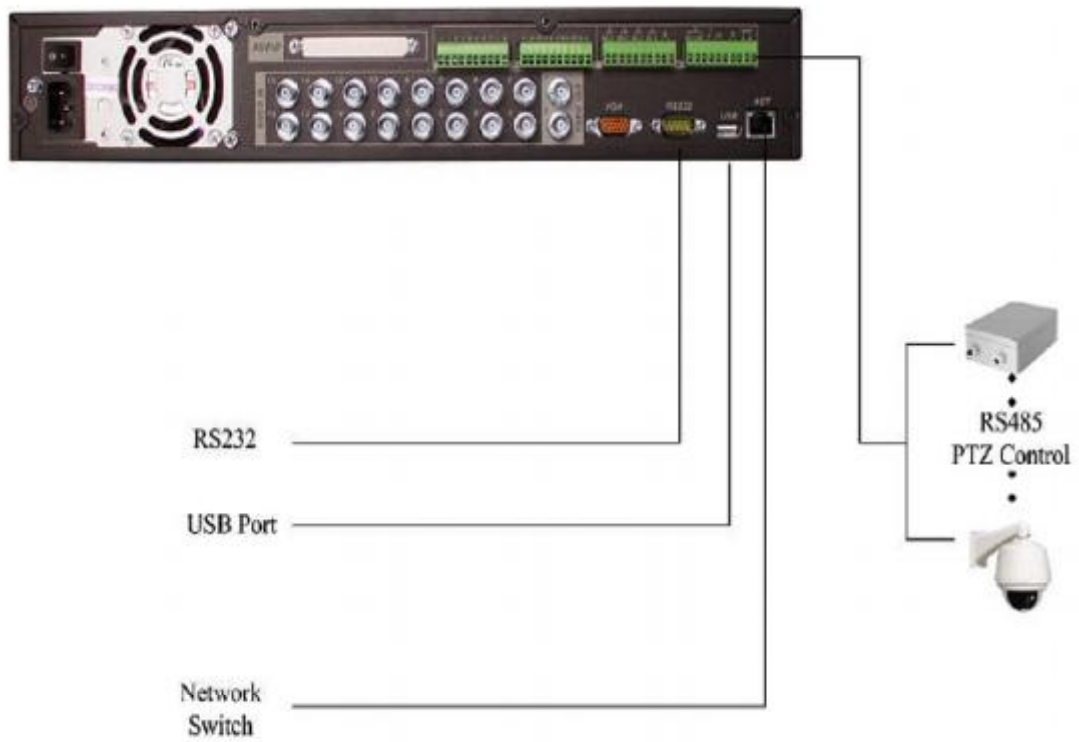

Figure 3-12

## 4 Overview of Navigation and Controls

Before operation, please make sure you have properly installed HDDs and all the cable connections.

### 4.1 Login, Logout & Main Menu

#### 4.1.1 Login

When the system boots up, default video display is in multiple-window mode.

Click Enter or left click mouse, you can see the login interface. See Figure 4-1.

System consists of four accounts:

- Username: admin. Password: admin. (administrator, local and network)
- Username: 888888. Password: 888888. (administrator, local only)
- Username: 666666. Passwords: 666666 (Lower authority user who can only monitor, playback, backup and etc.)
- Username: default. Password: default (hidden user)

For your system security, please modify you password after first login.

You can use USB mouse, front panel, remote controller or keyboard to input. About input

method: Click **123** to switch between numerics, upper and lower case alpha and symbols.

#### Note:

If more than three login failure attempts occur within 30 minutes the DVR will alarm and this will result in an account lock. To release, reboot the DVR or wait 30 minutes to clear.



Figure 4-1

#### 4.1.2 Main Menu

After you log in, the system main menu is displayed. See Figure 4-2.

There are a total of six icons: Search, Information, Setting, Backup, Advanced and Shutdown. If you move the cursor to highlight the icon you then double click mouse to enter the sub-menu.

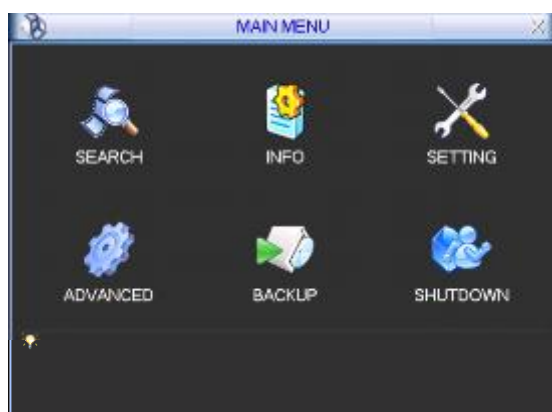

Figure 4-2

### 4.1.3 Logout

There are two ways for you to log out.

One is from menu option:

In the main menu, click shutdown button, you will see the interface shown below. See Figure 4-3.

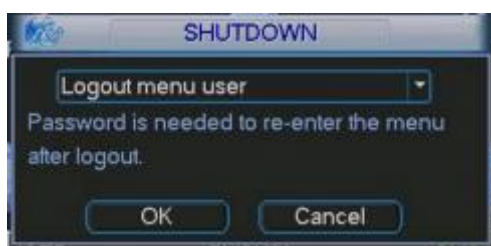

Figure 4-3

There are several options available. See Figure 4-4.

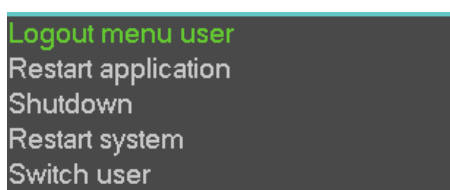

Figure 4-4

The other option is to press the power button on the **front** panel for at least 3 seconds and system will stop all operations. Then you can click the power button in the rear panel to turn off the DVR.

### 4.1.4 Auto Resume after Power Failure

The system can automatically backup video and resume previous working status after power failure.

### 4.1.5 Replace Button Battery (If DVR loses time or will not display correct date/time)



Please make sure to use the same battery model if possible. We recommend replacing battery regularly to guarantee system time accuracy. If DVR is not connected to power for long periods this will quickly drain button battery.

## 4.2 Recording Operation

### 4.2.1 Live Viewing

When you login, the system is in live viewing mode. You can see system date, time and channel name. If you want to change system date and time, you can refer to general settings (Main Menu->Setting->General). If you want to modify the channel name, please refer to the display settings (Main Menu->Setting->Display)

1		Recording status	3		Video loss
2		Motion detection	4		Camera lock

Note: Please refer to the following sheet for channel status.  stands for opening switch function,  stands for closing switch function.

### 4.2.2 Manual record

#### Note:

You need to have proper rights to implement the following operations. Please make sure the HDDs have been properly installed.

#### 4.2.2.1 Manual record menu

There are two ways for you to go to the manual record menu.

- Right click mouse or in the main menu, Advanced->Manual Record.
- In live viewing mode, click record button in the front panel or record button in the remote control.

Manual record menu is shown as in Figure 4-5.

#### 4.2.2.2 Basic operation

There are three statuses: schedule/manual/stop. Highlight icon“○” to select corresponding channel.

- Manual: the highest priority. After manual setup, all selected channels will begin ordinary recording.
- Schedule: channel records as you have set in recording setup (Main Menu->Setting->Schedule)
- Stop: all channels stop recording.



Figure 4-5

#### 4.2.2.3 Enable/disable record

Please check current channel status: “○” means it is in recording status,

“●” means it is not in recording status.

You can use mouse or direction key to highlight channel number. See Figure 4-6.



Figure 4-6

#### 4.2.2.4 Enable all channel recording

Highlight  below **All** to enable all channel recording.

#### **All channel Schedule record**

Please highlight “ALL” after “Schedule”. See Figure 4-7.

When system is in schedule recording, all channels will record as you have previously set (Main menu->Setting->Schedule).

The corresponding indication light in front panel will turn on.



Figure 4-7

#### **All channel Manual record**

Please highlight “ALL” after “Manual.” See Figure 4-8.

When system is in manual recording, all scheduled set up you have set will be deleted.

((Main menu->Setting->Schedule)).

You will see indication lights on front panel turn on and system begins manual recording.



Figure 4-8

#### 4.2.2.5 Stop all channel recording

Please highlight “ALL” after “Stop”. See Figure 4-9.

System stops all channel recording no matter what mode you have set in the menu (Main menu->Setting->Schedule)



Figure 4-9

### 4.3 Search & Playback

#### 4.3.1 Search Menu

There are two ways for you to go to search menu.

- Click Pause/Play button in the remote control.
- Click search in the main menu.

Search interface is shown as below. See Figure 4-10.

Usually there are three file types:

- R: regular recording file.
- A: external alarm recording file.
- M: motion detection recording file
- C: card and pos test overlay recording file (For special series only)

There are several playback windows. System supports 2-ch playback.



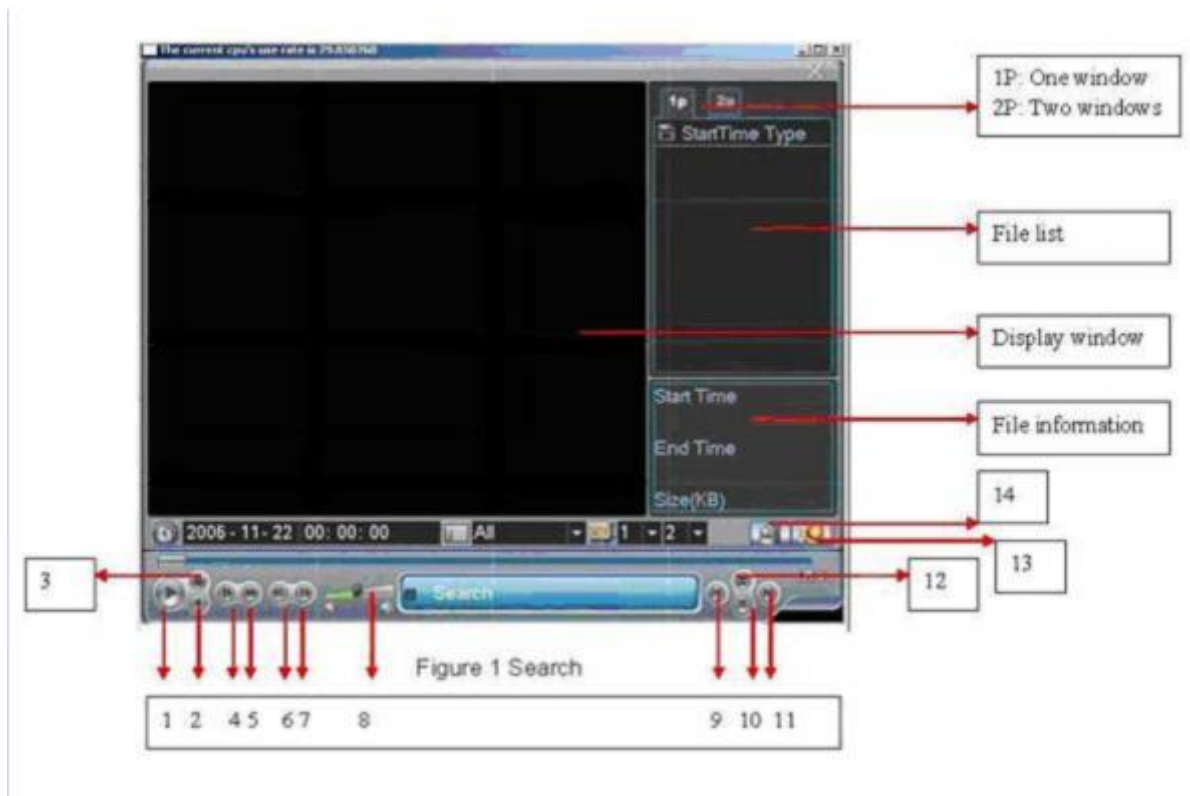

Figure 4-10

Please refer to the following sheet for more information.

Reference Number	Function
1	Play
2	Backward
3	Stop
4	Slow play
5	Fast play
6	Previous frame
7	Next frame
8	Volume
9	Previous file
10	Next channel
11	Next file
12	Previous channel
13	Search
14	Backup

This DVR supports 2-channel simultaneous playback.

### 4.3.2 Basic Operation

#### 4.3.2.1 Playback

There are various search modes: video type, channel number or time. The system can display 32 files on one screen. You can use page up/down button to view if there is more

than one page. Select the file name and double click mouse (or click enter button) to view file content.

#### 4.3.2.2 Accurate playback

Input time (h/m/s) in the time column and then click playback button.

#### 4.3.2.3 Synchronized playback function when playback

During the playback process, click channel number using numeric key to switch to the corresponding video channel at the same time.

#### 4.3.2.4 Digital zoom

When the system is in full-screen playback mode, drag your mouse on the screen to select a section and then left click mouse to select digital zoom. You can right click mouse to exit.

#### 4.3.2.5 File backup

System supports backup operation during search. Just enter a √ before file name (multiple choices) and then click the backup button (Button 14 in Figure 4-10).

#### 4.3.2.6 Slow playback and fast playback

Please refer to the following sheet for slow play and fast playback function.

Button	Illustration	Remarks
Fast play button ▶▶	In playback mode, click this button to switch between various fast play modes such as fast play 1, fast play 2 and more. (Fast play 1 means fast play level 1 and is not speed related)	Frame rate may vary due to different versions.
Slow play button ▶ (Or you can turn the outer ring jog counter clockwise.)	In playback mode, click this button to switch between various slow play modes such as slow play 1 or slow play 2.	
3、 Play/Pause ▶	In slow playback mode, click this button to switch between play/pause modes.	
4、 Previous/next	In playback mode, you can click ◀ and ▶   to view previous or next video in current channel.	

#### 4.3.2.7 Fast forward/fast backward and frame by frame playback

Special Functions of Shuttle and Jog	Illustration	Remarks
--------------------------------------	--------------	---------

Fast forward (outer ring jog clockwise)	When in playback, turn the shuttle (outer ring) clockwise one turn: you can view in fast level 1 Turn it twice you get fast level 2. You can continue turning to get different speeds.	In forward or backward mode, double click Pause/Play button to get normal playback.
Fast backward (outer ring counter jog clockwise)	When in playback, turn the shuttle (outer ring) anti clock-wise one turn, to view in backward level 1. Turn it twice to get backward level 2. You can continue turning to get different speeds.	Frame rate may vary due to different version.
Manual playback frame by frame	In playback mode, click play/pause button, slowly turn the jog (inner dial) clock-wise to view frame by frame, counter clock wise to view I frame playback.	

#### 4.3.2.8 Backward playback and frame by frame playback

Button	Illustration	Remarks
Backward play  in playback interface.	In normal playback mode, left click backward play button, system begins backward playback. Double click backward play button again, system goes to pause mode.	When system is in backward play or frame by frame playback mode, you can click play button to go to normal playback.
Manual playback frame by frame.	Click pause button in normal playback mode and slowly turn the jog (inner dial) clock-wise to view frame by frame or anti clock wise to view I frame playback.	

Note:

All the operations here (such as playback speed, channel, time and progress) are related to hardware version. Note that some series DVRs do not support some functions or playback speeds.

#### 4.3.3 Calendar

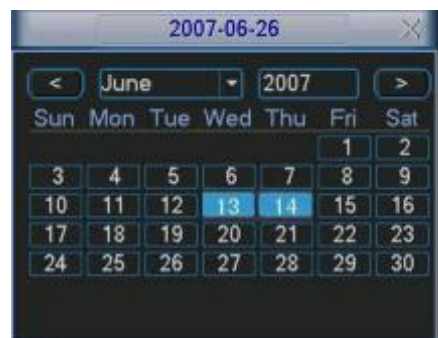

Click calendar icon  in Figure 4-10, and the system displays a calendar for your reference. Highlighted dates mean that there are recorded files for that day. You can click blue dates to view file lists. In Figure 4-11, there are video files for March 13th and 14th. Double click the dates to view file lists.

#### 4.4 Record Setup (Schedule)

Figure 4-11

When the system boots up, it is in default 24-hour regular mode. You can set record type and time in schedule interface.

##### 4.4.1 Schedule Menu

In the main menu, from setting to schedule, you can go to schedule menu. See Figure 4-12.

There are three record types: R-Regular, MD-Motion detection, A- Alarm.



Figure 4-12

##### 4.4.2 Basic Operation

There are total six periods. See Figure 4-12.

- Channel: Please select the channel number first. You can select “all” if you want to set all channels.
- Week day: There are eight options: ranges from Saturday to Sunday and All.
- Prerecord: System supports prerecord function. The previous one to three seconds of video before an alarm occurs can be included in recorded video.
- Redundancy: System supports redundancy backup function. You can highlight Redundancy button to activate this function. Please note, before enabling this function, please set at least one HDD as redundant.(Main menu->Advanced->HDD Management)
- Record types: There are three types: regular, motion detection (MD) and Alarm.

Please highlight icon  to select the corresponding function. After setup please click save button and system then returns to the previous menu.

At the bottom of the menu, there are colour bars for your reference. Green stands for regular recording, yellow stands for motion detection and red stands for alarm recording.

**SPECIAL NOTE:** If you are selecting one period e.g 00:00 ~ 24:00 you should only highlight Regular, MD or Alarm box for Period 1. The six periods allow for a 24 hour period to be broken down into a maximum of six periods as per diagram above.

#### 4.4.2.1 Quick Setup

This function allows you to copy one channel setup to another. After setting channel 1, you can click copy button and then turn to channel 2 and then click paste button. You can finish settings for one channel and then click the save button or you can finish all setup and then click save button.

#### 4.4.2.2 Redundancy

Redundancy function allows you to copy recorded files on other disk drives. These files are created, packaged and closed simultaneously. When there is file damage on one disk, you can access the other disk. You can use this function to maintain data reliability and safety. In the main menu, from Setting to Schedule, you can highlight redundancy button to enable this function. See Figure 4-12.

In the main menu, from Advanced to HDD management, you can set one or more disk(s) as redundant. You can select from the dropdown list. See .. System auto overwrites old files once hard disk is full.

Please note only read/write disk or read-only disk can backup file and support file search function, so you need to set at least one read-write disk otherwise you cannot record video.

#### Note

##### About redundancy setup:



Figure 4-13

- If current channel is not recording, current setup gets activated when the channel begins recording the next time.
- If current channel is recording now, the redundancy setup will get activated right away so the current file will be closed and a new file opened on each hard drive media.

After setup complete please click the save button and system will return to the previous menu.

#### Playback or search on the Redundant disk.

There are two ways for you to playback or search on the Redundant disk.

- Set redundant disk(s) as read-only disk or read-write disk (Main menu->Advanced->HDD management). See ..System needs to reboot to get setup activated. Now you can search or playback file in redundant disk.

- Dismantle the disk and play it in another PC.

## 4.5 Detect

### 4.5.1 Go to Motion Detect Menu

In the main menu, from Setting to Detect, you can see motion detect interface. See Figure 4-14.

### 4.5.2 Motion Detect

Motion Detection menu is shown as below. See Figure 4-14.

#### 4.5.2 Motion Detect

Detection menu is shown as below. See Figure 4-14.

**Channel:** Select the channel you want to implement motion detection.

**Type:** In the dropdown list, select motion detection option.

**Record channel:** Select the channel to activate recording function once alarm is triggered. Please make sure you have set MD record in encode interface(Main Menu->Setting->Schedule) and schedule record in manual record interface(Main Menu->Advanced->Manual Record)

**Enable tour:** Here is where you activate tours with different cameras.

**Latch:** When motion detection completes, system automatically delays detecting for a specified time. The value ranges from 10-300 seconds.

**PTZ preset:** Click set button and the interface is shown as in Figure 4-15. Here you can set presets for one or more channels.

**Region:** Click “select” button to set motion detection region. See Figure 4-16.

**Sensitivity:** There are six levels. The sixth level is the highest sensitivity.

**Alarm output:** When alarm triggered, system enables peripheral alarm devices.

**Show message:** System displays message on the screen to alert you when alarm is triggered. Please highlight icon to select the corresponding function. After setup please click save button and system returns to the previous menu.

**Note:**

**In motion detection mode, you cannot use copy/paste to set channel setup since the video in each channel may not be the same. In Figure 4-15, you can left click the mouse and then drag it to set a region for motion detection. Click Fn to toggle between setting or withdrawing motion detection.**

**After setting, click enter button to exit.**

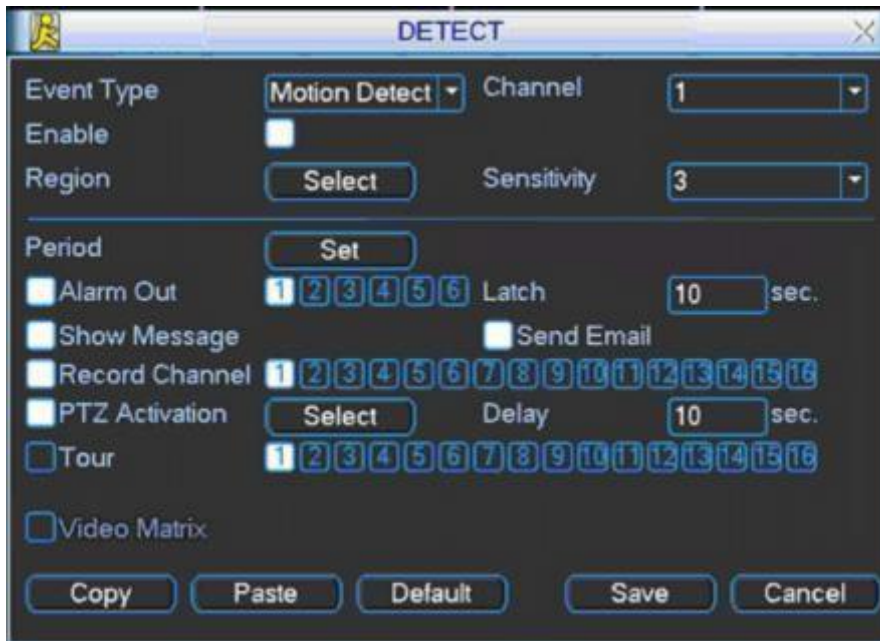

Figure 4-14

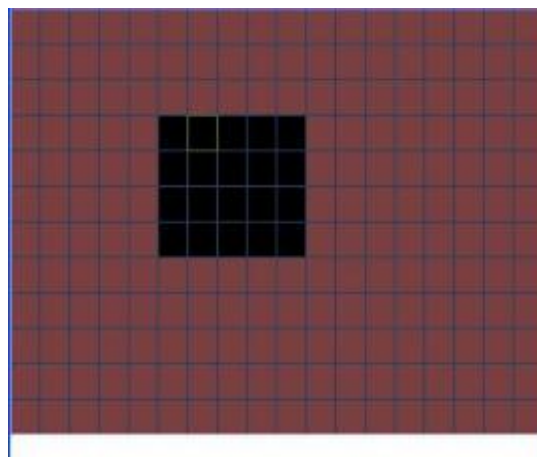

Figure 4-15

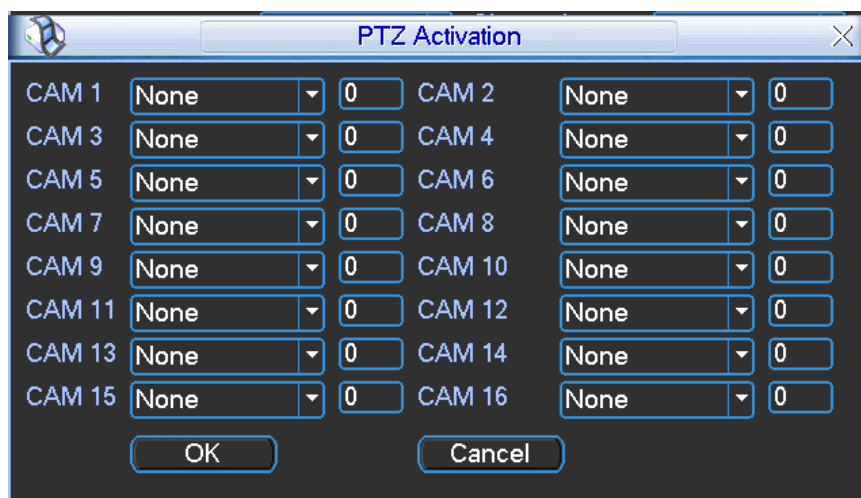
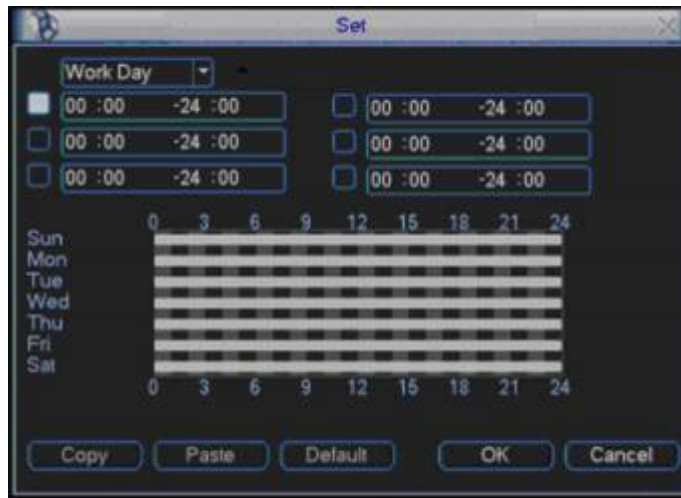

Figure 4-16

Figure 4-17





### 4.5.3 Video Loss

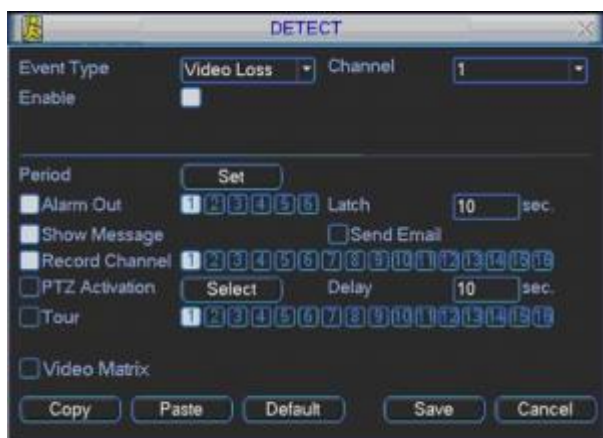

Figure 4-18

In Figure 4-14, select Video Loss in the Type item. You can see the interface is shown as in Figure 4-17. This function allows you to be informed when video loss occurs. You can enable alarm output channel and then enable show message function.

**Channel:** Select the channel you want to enable lens shading alarm.

**Type:** Select video loss.

**Record channel:** Select the channel to record when video loss occurs..

**Alarm output:** Activate peripheral alarm device when video loss occurs.

**Enable tour:** Here is where you activate a tour.

**Latch:** When motion detection completes, system automatically delays detecting for a specified time. The value ranges from 10-300 seconds.

**PTZ preset:** Click set button to set preset for one or all channels.

**Period 1/2:** Set two periods (00.00-24.00).

**Alarm output:** When video loss occurs, system enables peripheral alarm devices.

Please highlight icon to enable this function

**Show message:** System displays message on the screen to alert you when alarm occurs.

Please highlight icon to enable this function

### 4.5.4 Camera Masking



Figure 4-18a

When someone masks lens, the system can alert you to guarantee video continuity. Camera mask detection interface is shown as in Figure 4-18a .

**Channel:** Select the channel you want to enable camera mask detection function.

**Type:** Select camera mask detect from the dropdown list.

**Record channel:** Select the channel to record when camera mask occurs.

**Alarm output:** Activate peripheral alarm device when camera mask occurs.

**Enable tour:** This activates a tour between different cameras.

**Latch:** when motion detection completes, system auto delays detecting for a specified time. The value ranges from 10-300 seconds.

**PTZ preset:** Click set button to set preset for one or all channels. See Figure 4-16.

**Period 1/2:** Enables two periods to be set with a 24 hour period.

**Alarm output:** when camera masking occurs, system enables peripheral alarm device. Please highlight icon to enable this function

**Show message:** System displays message on the screen to alert you once alarm occurs. Please highlight icon to enable this function

**Note:** In this interface, copy/paste function is only valid for the same type, which means you cannot copy a channel setup in video loss mode to camera mask detect mode.

## 4.6 Alarm Setup and Alarm Activation

Before operation, please make sure you have properly connected alarm devices such as buzzer.

### 4.6.1 Go to alarm setup interface

In the main menu, from Setting to Alarm, you can see alarm setup interface. See Figure 4-19.

### 4.6.2 Alarm setup

Alarm interface is shown as below. See Figure 4-19.

**Alarm in:** Set channel number.

**Source of alarm:** There are two alarm sources: local input or network input.

**Type:** normally open or normally closed.

**Record channel:** You can select a channel to record alarm video (Multiple choices). At the same time you need to set alarm record in schedule interface (Main Menu->Setting->Schedule) and select schedule record in manual record interface (Main Menu->Advance->Manual Record).

**Latch:** Allows setting of the latch time after the alarm finishes from 10 to 300 seconds. System automatically delays by specified setting in seconds, the switching off of the alarm and activated output, after external alarm is cancelled.

**PTZ preset:** This activates PTZ control.

**Relay out:** Select required alarm activation output channel (multiple choices).

**Show message:** System displays message on the screen to alert you once alarm occurs.

**Period 1 and period 2:** Set required time and alarm displays.

Please highlight icon to select the corresponding function. After setup click save button and system will return to the previous menu.

**ALARM**

Event Type: Local Alarm Alarm In: 1

Enable:  Type: Normal Open

---

Period: Set

Alarm Out: 1 2 3 4 5 6 Latch: 10 sec.

Show Message  Send Email

Record Channel: 1 2 3 4 5 6 7 8 9 10 11 12 13 14 15 16

PTZ Activation: Select Delay: 10 sec.

Tour: 1 2 3 4 5 6 7 8 9 10 11 12 13 14 15 16

Video Matrix:

Copy Paste Default Save Cancel

**PTZ Activation**

CAM 1	None	0	CAM 2	None	0
CAM 3	None	0	CAM 4	None	0
CAM 5	None	0	CAM 6	None	0
CAM 7	None	0	CAM 8	None	0
CAM 9	None	0	CAM 10	None	0
CAM 11	None	0	CAM 12	None	0
CAM 13	None	0	CAM 14	None	0
CAM 15	None	0	CAM 16	None	0

OK Cancel

**Set**

Work Day:  Set

00 :00 -24 :00  00 :00 -24 :00

00 :00 -24 :00  00 :00 -24 :00

00 :00 -24 :00  00 :00 -24 :00

	0	3	6	9	12	15	18	21	24
Sun									
Mon									
Tue									
Wed									
Thu									
Fri									
Sat									

Copy Paste Default OK Cancel

## 4.7 Backup

Click backup icon in the main menu, there are two function items: detect device and backup files.

### 4.7.1 Detect Device

This is where you view device information. See Figure 4-20.

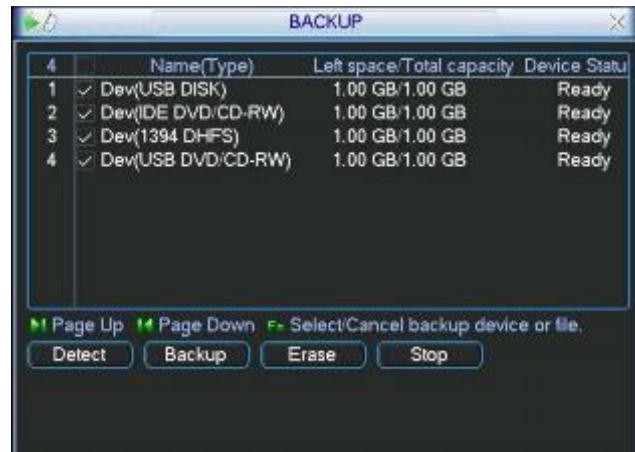

Figure 4-20

### 4.7.2 Backup

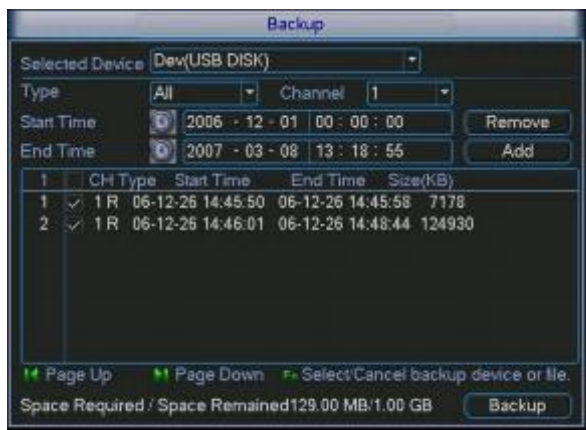

Figure 4-21

Select backup device and then channel, file start time and end time.

Click add button, system begins search.

All matched files are listed below.

System automatically calculates the capacity needed and remaining. See figure 4-21.

System only backs up files with a ✓

before channel name. You can use Fn or cancel button to delete ✓ after file serial number.

Click backup button to backup selected files. There is a progress bar for you reference. When the system completes backup you will see a display box prompting successful backup.



Figure 4-22

Figure 4-22

Click backup button, system begins burning. At the same time, the backup button becomes a stop button. You can view the remaining time and progress bar at the bottom left. See figure 4-22.

#### Tips:

During backup process, you can click ESC to exit current interface but the system will not terminate backup process.

#### Note:

When you click stop button during the burning process, there are two conditions for different devices:

- For CD/DVD burner device, the stop function becomes activated immediately and there is no data in the burner.
- For USB device, system can backup the data before you click stop button. For example, if there is a file of 10 minutes, when you click stop after five minutes backup, system only save the previous 5-minute data in the device.

The file name format usually is: SN\_CH+channel number+time Y+M+D+H+M+S. In the file name, the YDM format is the same as you set in general interface. (Main Menu ->Setting ->General).

## 4.8 PTZ Control and Colour Setup

**Note:** All the operations here are based on PELCOD protocol. For other protocols, there may be some differences.

### 4.8.1 Cable Connection

Please follow the procedures below to go on cable connection

- Connect the dome RS485 port to DVR 485 port.
- Connect dome video output cable to DVR video input port.
- Connect power adapter to the dome.

### 4.8.2 PTZ Setup

**Note:** The camera video should be in the current screen. Before setup, please check the following connections are correct:

- PTZ and decoder connection is right. Decoder address setup is right.
- Decoder A (B) line connects with DVR A (B) line.

Boot up the DVR, input user name and password.

In the main menu, click setting, and then click Pan/Tilt Control button. The interface is shown as in figure 4-23. Here you can set the following items:

- Channel: Select the current camera channel.
- Protocol: Select corresponding PTZ protocol (such as PELCOD)
- Address: Default address is 1. Best to keep channel and address numbers the same.
- Baud rate: Select corresponding baud rate. Set at 2400.
- Data bits: Select corresponding data bits. Default value is 8.
- Stop bits: Select corresponding stop bits. Default value is 1.
- Parity: There are three options: odd/even/none. Default setup is none.

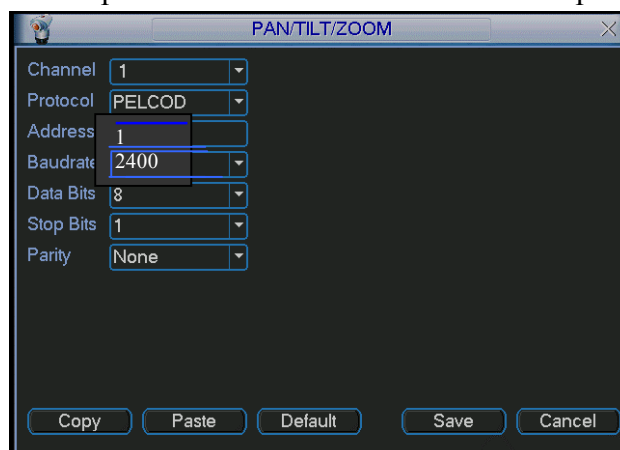
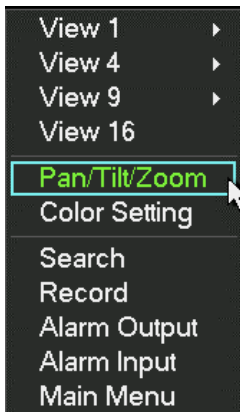

Figure 4-23

After setup click save button.



In one window display mode, right click mouse (click “Fn” Button in the front panel or click “Fn” key in the remote control) and the interface as shown in figure 4-24 is displayed.

Click Pan/Tilt/Zoom and the interface below is displayed. See figure 4-25.

Figure 4-24

Here you can set the following items:

- Step: value ranges from 1 to 8.
- Zoom
- Focus
- Iris









Click icon  and  to adjust zoom, focus and iris.



Figure 4-25

In figure 4-25, please click direction arrows (See figure 4-26) to adjust PTZ position. There are total 8 direction arrows.

Here is a sheet for your reference.

Name	Function key	function	Shortcut key	Function key	function	Shortcut Key
Zoom		Near	▶		Far	▶▶
Focus		Near	◀		Far	▶▶
Iris		close	◀		Open	▶

#### 4.9 Preset/ Patrol/Pattern/Scan

In figure 4-25, click the “set” button.

The interface is as shown below. See figure 4-28.

Here you can set the following items:

- Preset
- Tour
- Pattern
- Border



Figure 4-28



In figure 4-25, click page switch button, the interface is shown as in figure 4-29.

Here you can activate the following functions:

- Preset
- Patrol(Tour)
- Pattern
- Aux on
- Aux off
- Auto scan
- Auto pan
- Light on

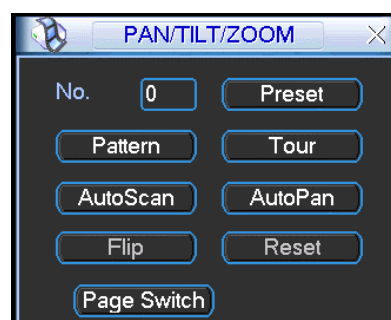

Figure 4-29

Note: The following setups are usually operated in figure 4-25, figure 4-28 and figure 4-29.

#### 4.9.1 Preset Setup

In Figure 4-25, use eight direction arrows to adjust camera to the proper position.

In Figure 4-28, click preset button and input preset number.

The interface is shown

as in Figure 4-30.

Now you can add this preset to one patrol (tour).

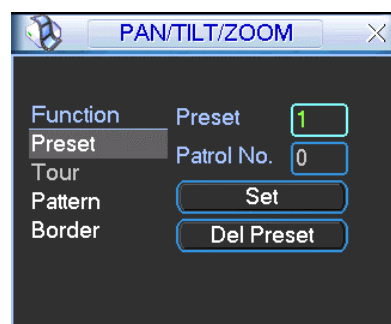

Figure 4-30

#### 4.9.2 Activate Preset

In figure 4-29, please input preset number in the No. box and click preset button.

#### 4.9.3 Patrol setup (Tour Setup)

In figure 4-28, click patrol button. The interface is as shown in figure 4-31. Input preset number and add this preset to a patrol (tour). For each patrol (tour), you can input a maximum of 80 presets.



Figure 4-31

#### 4.9.4 Activate Patrol (tour)

In figure 4-28, input patrol (tour) number in the No. box and click patrol button

#### 4.9.5 Pattern Setup

In figure 4-28, click pattern button and then click “begin” button. The interface is as shown in figure 4-32. Then you can go to figure 4-25 to modify zoom, focus, and iris.

Go back to figure 4-32 and click “end” button. You can save all these operations as pattern 1.



Figure 4-32

#### 4.9.6 Activate Pattern Function

In figure 4-29, input mode value in the No. box and click Pattern button.

#### 4.9.7 Auto Scan Setup

In figure 4-28 click border button. The interface is as shown in figure 4-23.

Please go to figure 4-25, use direction arrows to select camera left limit.

Then please go to figure 4-33 and click left limit button. Repeat the above procedures to set right limit.



Figure 4-33

#### 4.9.8 Activate Auto Scan

In figure 4-29, click “Auto Scan” button and the system begins auto scan. Correspondingly, the auto scan button becomes a stop button. Click stop button to terminate scan operation.

#### 4.10 Dome Menu Control

In Figure 4-29, click page switch button, the interface is shown as below. See Figure 4-34. Click menu to enter dome menu. The direction arrows here are to control dome menu. Click page switch button, system goes back to Figure 4-25

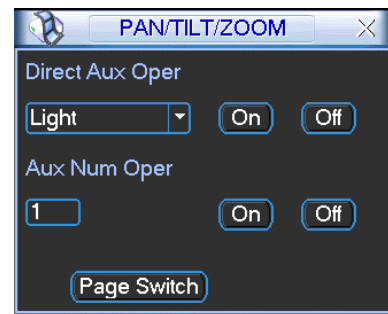

Figure 4-34



## 5 Menu Operations and Controls

### 5.1 Menu Tree

The DVR series menu tree is shown as below.

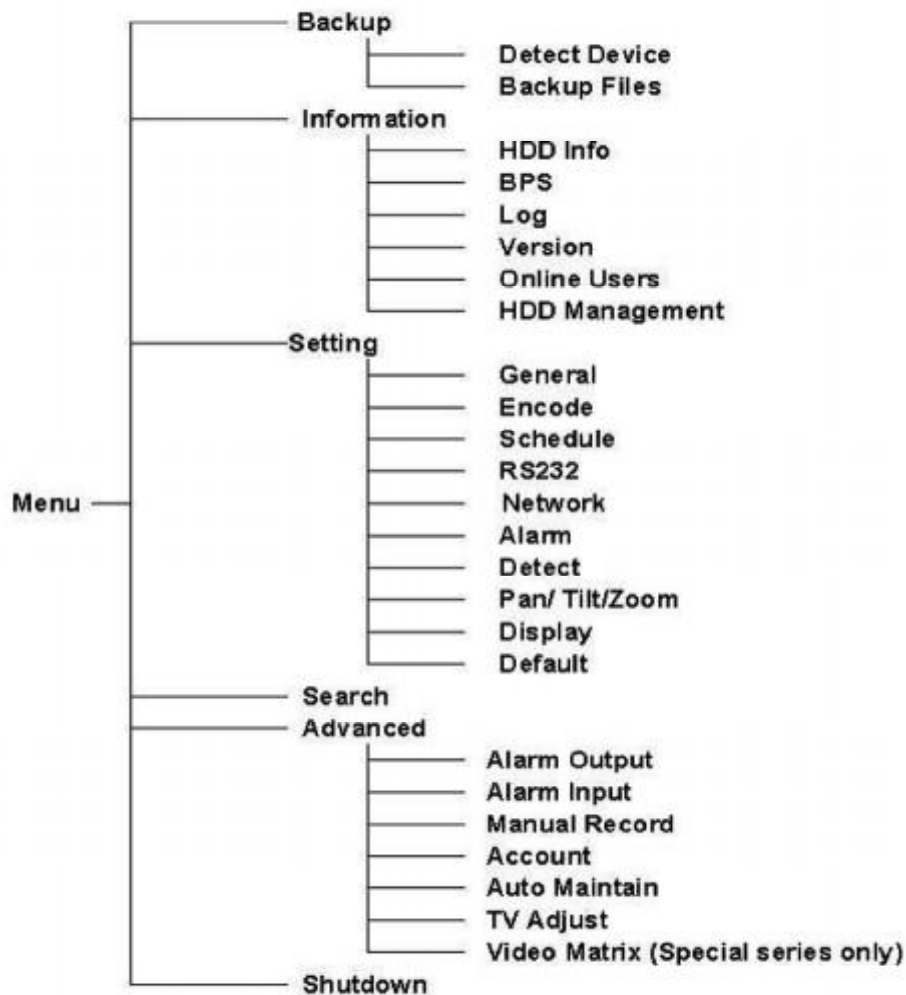

### 5.2 Main Menu

After you logged in, the system main menu is shown as below. See Figure 5-1 . There are a total of six icons: Search, Information, Setting, Backup, Advanced and Shutdown. Move the cursor to highlight the icon, and then double click mouse to enter the sub-menu.

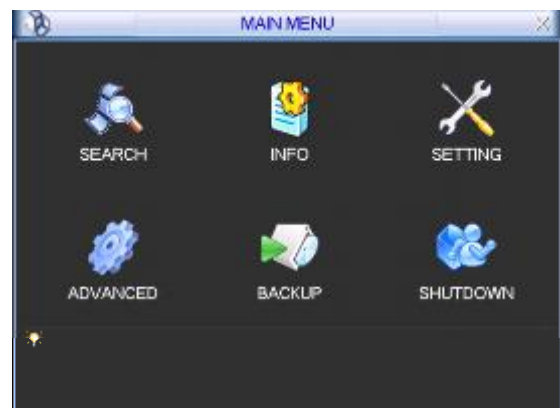

Figure 5-1

Figure 5-1

## 5.3 Setting

In main menu, highlight Setting icon and double click mouse. System setting interface is shown as below. See **Error! Reference source not found.**



Figure 5-2

### 5.3.1 General

General setting includes the following items. See Figure 5-2.

- **System time:** Set system time
- **Date format:** There are three types: YYYY-MM-DD: MM-DD-YYYYY or DD-MM-YYYY.
- **Date separator:** There are three denotations to separate date: dot, hyphen and colon.
- **Time format:** there are two types: 24-hour mode or 12-hour mode.
- **Language:** System supports various languages: Chinese (simplified), Chinese (Traditional), English, Italian, Japanese, French, Spanish (All languages listed here are optional. Slight difference maybe found in various series.)
- **HDD full:** Select working mode when hard disk is full. There are two options: stop recording or Overwrite. (Overwrite will overwrite oldest file saved on HDD).
- **Pack duration:** Set record duration. Default value is 60 minutes per file created.
- **DVR No:** When you are using one remote control to control several DVRs, you can give a name to each DVR for your management. Default is 8.
- **Video standard:** There are two formats: NTSC and PAL.
- **Auto logout:** Set auto logout interval once login user remains inactive for a specified time. Value ranges from 0 to 60 minutes.

#### Note:

Since system time is very important, do not modify time casually. It is recommended to stop all recording and format the hard drive before changing date or time.

After completing setup please click the save button and system will return to the previous menu.



Figure 5-2

### 5.3.2 Encode

Encode setting includes the following items. See Figure 5-. Please note some series do not support extra stream.

- **Channel:** Select the channel you want.
  - **Compression:** System supports H.264 or you can select from the dropdown list.
  - **Resolution:** System supports various resolutions. You can select from the dropdown list.
  - **Bit rate type:** System supports two types: CBR and VBR. In VBR mode, you can set video quality. Always use VBR when networking unit. Note that the a Quality (1 – 6 high) setting is only visible/selectable when Bit Rate Type is set to VBR. When CBR is set, the bit rate denotes the upper limit of data stream. In altering this setting the DVR will automatically adjust quality to suit the data stream/bit rate selected.
  - **Frame rate:** There are six levels: 1 f/s,2f/s,3f/s, 6f/s,12f/s,25f/s. (Some series DVRs only support PAL 25f/s )
  - **Enable audio:** You can enable or disable audio.
- ◇ Cover area (Privacy mask): Set window blanking section. You can drag your mouse to set section size.
- ◇ Time display: Select system display time or not when you playback.
- ◇ Channel display: Select channel number or not when you playback.

System default setup is:

- Channel:1
- Compression:H.264
- Resolution: CIF
- Bit rate: CBR
- Quality: 4
- Frame rate: 25f/s

Please highlight icon  to select the corresponding function.

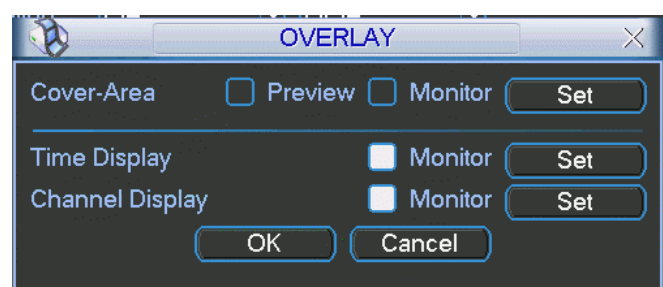

Figure 5-4

### 5.3.3 Schedule

Please refer to chapter 4.4 Schedule.

### 5.3.4 RS232

RS232 interface is shown as below. Here are five items. See 5.5.

- **Function:** There are various devices for you to select.

- Baud rate: Select baud rate.
- Data bit: Select data bits.
- Stop bit: There are three values: 1, 1.5 and 2.
- Parity: there are three choices: none, odd and even.

After completing setup please click save button and system will return to the previous menu.

NOTE: THIS FUNCTION IS NOT SUPPORTED.



Figure 5-5

### 5.3.5 Network

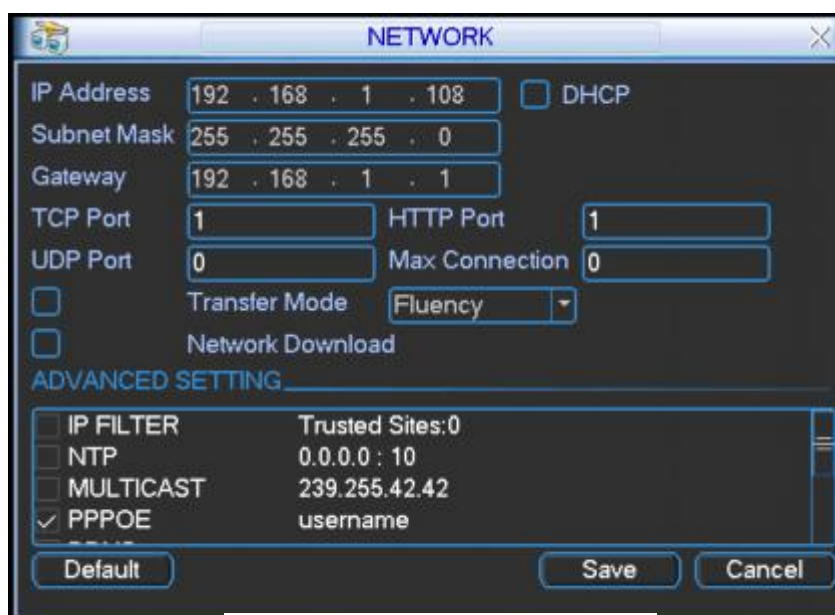

Figure 5-3

This is where you input network information. See Figure 5-3.

- IP address: Input local IP address.
- DHCP: It an auto search IP function. When enabling DHCP function, you cannot modify IP/Subnet mask /Gateway. These values are supplied by DHCP function. If you have not enabled DHCP function, IP address, Subnet Mask and Gateway are displayed as zero fields. You need to disable the DHCP function to view current IP information. When PPPoE is operating, you cannot modify the IP address, Subnet Mask or Gateway.
- TCP port: Default value is 37777. (System server port 37778 is reserved for UDP use.)
- UDP port: Default value is 37778.

- HTTP port: Default value is 80.
- Max connection: System supports a maximal of 10 users. 0 means there is no connection limit.
- Transfer mode: Here you can select the priority between fluency or video quality.
- Network download: System can process the downloaded data first if you enable this function.

After completing setups click save button and system returns to the previous menu.

### 5.3.5.1 Advanced Setup

Advanced setup interface is shown as in Figure 5-4. Please draw a circle to enable corresponding function and then double click current item to go to setup interface.

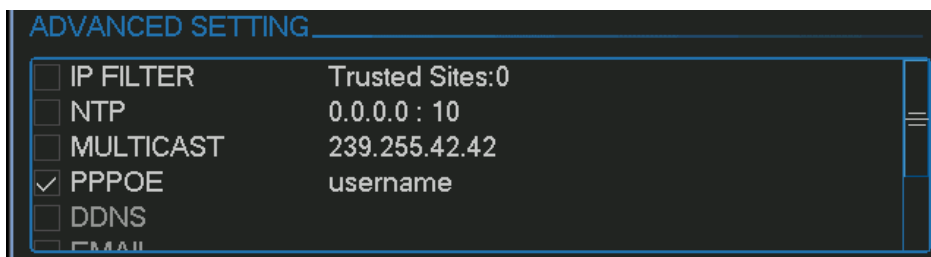

Figure 5-4

### 5.3.5.2 IP Filter

IP filter interface is shown as in Figure 5-5. You can add IP in the following list. The list supports max 64 IP addresses. Please note after you enabled this function, only the IP listed below can access current DVR. If you disable this function, all IP addresses can access current DVR.



Figure 5-5

### 5.3.5.3 Multiple Cast Setup

Multiple-cast setup interface is shown as in Figure 5-6.

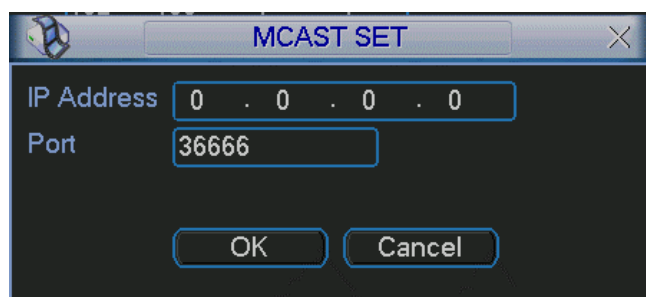

Figure 5-6

Here you can set a multiple cast group. Please refer to the following sheet for detailed information.

- IP multiple cast group address
  - 224.0.0.0-239.255.255.255
  - “D” address space
    - The higher four-bit of the first byte=”1110”
- Reserved local multiple cast group address
  - 224.0.0.0-224.0.0.255
  - TTL=1 When sending out telegraph
  - For example
    - 224.0.0.1 All systems in the sub-net
    - 224.0.0.2 All routers in the sub-net
    - 224.0.0.4 DVMRP router
    - 224.0.0.5 OSPF router
    - 224.0.0.13 PIMv2 router
- Administrative scoped addressees
  - 239.0.0.0-239.255.255.255
  - Private address space
    - Like the single broadcast address of RFC1918
    - Cannot be used in Internet transmission
    - Used for multiple cast broadcast in limited space.

Except for the above mentioned addresses for special use, use other addresses. For example:  
 Multiple cast IP: 235.8.8.36  
 Multiple cast PORT: 3666.

#### 5.3.5.4 PPPoE

PPPoE interface is shown as in Figure 5-7.

Input “PPPoE name” and “PPPoE password” you get from your ISP (Internet service provider). Check that ISP offers this service.

Click save button. You need to restart DVR to activate your configuration.

After rebooting, IP camera will connect to Internet automatically. The IP in the PPPoE is the DVR dynamic value. You can access this IP to access the unit.

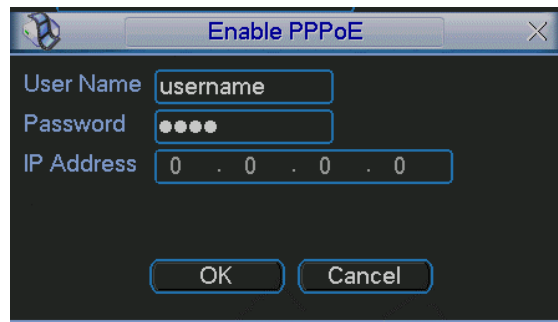

Figure 5-7

#### 5.3.5.5 NTP Setup

This option allows for the automatic updating of system time in the DVR so overcoming the need for changing from and to British Summer Time (BST).

You need to install SNTP server (Such as Absolute Time Server) in your PC first. In Windows XP, you can use command “net start w32time” to boot up NTP service.

NTP setup interface is shown as in Figure 5-8.

- Host IP: Input your PC address.
- Port: This series DVR supports TCP transmission only. Port default value is 123.
- Update interval: Minimum value is updating every 15 minutes.
- Time zone: select your corresponding time zone here.

Here is a list for your time zone setup.

City /Region Name	Time Zone
London	GMT+0
Berlin	GMT+1
Cairo	GMT+2
Moscow	GMT+3
New Deli	GMT+5
Bangkok	GMT+7
Beijing (Hong Kong)	GMT+8
Tokyo	GMT+9
Sydney	GMT+10
Hawaii	GMT-10
Alaska	GMT-9
Pacific Time(P.T)	GMT-8
American Mountain Time(M.T)	GMT-7
American Central Time(C.T)	GMT-6
American Eastern Time(E.T)	GMT-5
Atlantic Time	GMT-4
Brazil	GMT-3
Middle Atlantic Time	GMT-2

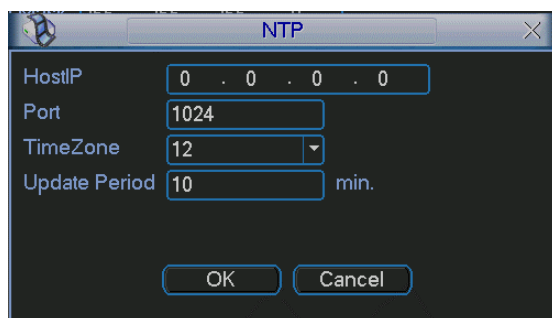

Figure 5-8

### 5.3.5.6 Email Setup

Email setup interface is shown as in Figure 5-9. Here you can set email server information.

**Note:**

You need to get the email address from your email service provider first.

Please use semicolon to separate the addresses.

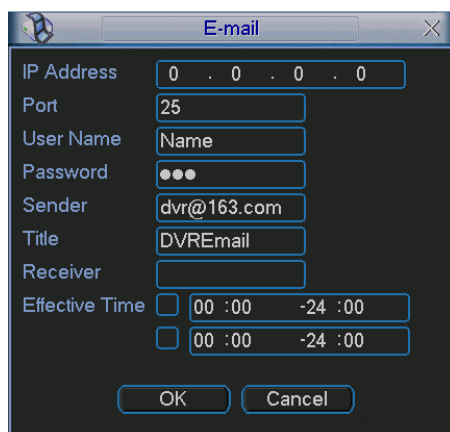

Figure 5-9

### 5.3.5.7 DDNS Setup

DDNS setup interface is shown in Figure 5-10.

You need a PC of fixed IP on the internet and DDNS is running in this PC. In other words, this PC is a DNS (domain name server).

In network DDNS, input your PPPoE name you get from you IPS and server IP (PC with DDNS ) . Click save button and then reboot system.

Click save button and system prompts for rebooting activate changes.

After rebooting, open IE and input as below:

http : //(DDNS server IP)/(virtual directory name)/webtest.htm

e.g.: http : //10.6.2.85/DVR \_DDNS/webtest.htm.)

Now you can open DDNSServer web search page.



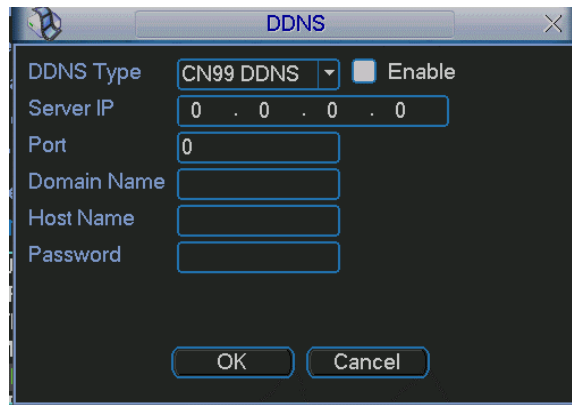

Figure 5-10

### 5.3.5.8 Alarm Server

You can set alarm in accordance with different alarm protocols. System can inform the alarm server when alarm occurs. See Figure 5-11.

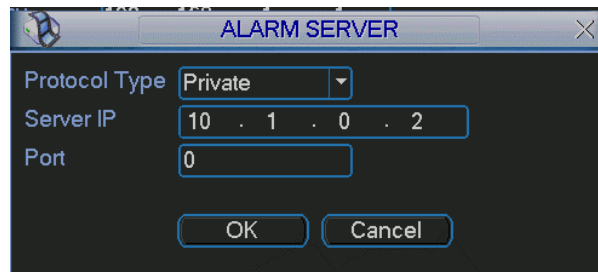

Figure 5-11

### 5.3.5.9 FTP

You need to download or buy FTP service tool (such as Ser-U FTP SERVER) to establish FTP service.

Please install Ser-U FTP SERVER first. From “start” -> “program” -> Serv-U FTP Server -> Serv-U Administrator. Now you can set user password and FTP folder. Please note you need to grant write rights to FTP upload user. See Figure 5-12.



Figure 5-12

You can use a PC or FTP login tool to test setup is right or not.

For example, you can login user ZHY to [FTP://10.10.7.7](ftp://10.10.7.7) and then test it can modify or delete folder or not. See Figure 5-13.



Figure 5-13

System also supports upload multiple DVRs to one FTP server. You can create multiple folders under this FTP.

In Figure 5-3, select FTP and then double click mouse. You can see the following interface. See Figure 5-14.

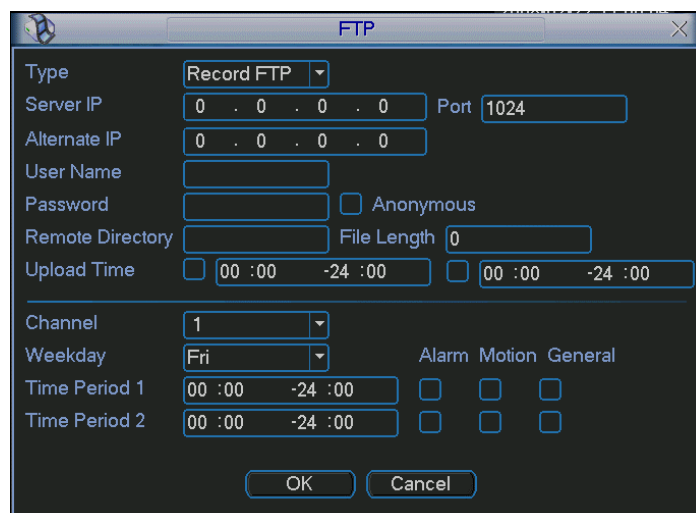



Figure 5-14

Please highlight the icon  in front of Enable to activate FTP function.

Now FTP can upload alarm video and motion detection video. Please note, when you are using this function, please make sure current upload channel is in motion detection or alarm record status and there is video available.

Here you can input FTP server address, port and etc.

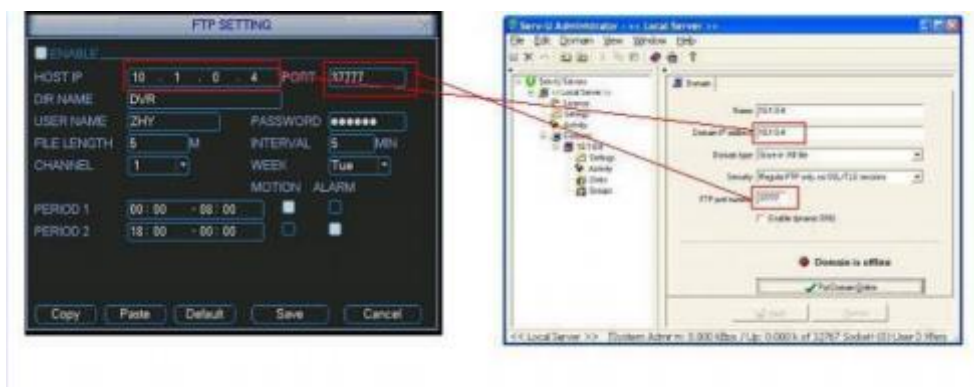

Figure 5-15

- File length: Upload file length. When setup is larger than the actual file length, system will upload the whole file. When setup here is smaller than the actual file length, system only uploads the set length and auto ignores the remaining section.
- When interval value is 0, system uploads all corresponding files.
- Period 1 and period 2: You can set two periods for one each channel.

System file name is shown as in . Figure 5-16.



Figure 5-16

### 5.3.6 Alarm

Please refer to chapter 4.6 Alarm Setup and Activation.

### 5.3.7 Detect

Please refer to chapter 4.5 Detect.

### 5.3.8 Pan/Tilt/Zoom

The pan/tilt/zoom setup includes the following items. Please select channel first. See figure 5-14.

**Protocol:** Select corresponding PTZ protocol such as PELCOD.

**Address:** Input corresponding PTZ address.

**Baud rate:** Select baud rate.

**Data bit:** Select data bit.

**Stop bit:** Select stop bit.

**Parity:** There are three choices: none, odd or even.

After completing setup please click the save button and system returns to the previous menu.

For detailed setup, please refer to chapter 4.9 preset/patrol/pattern/scan.

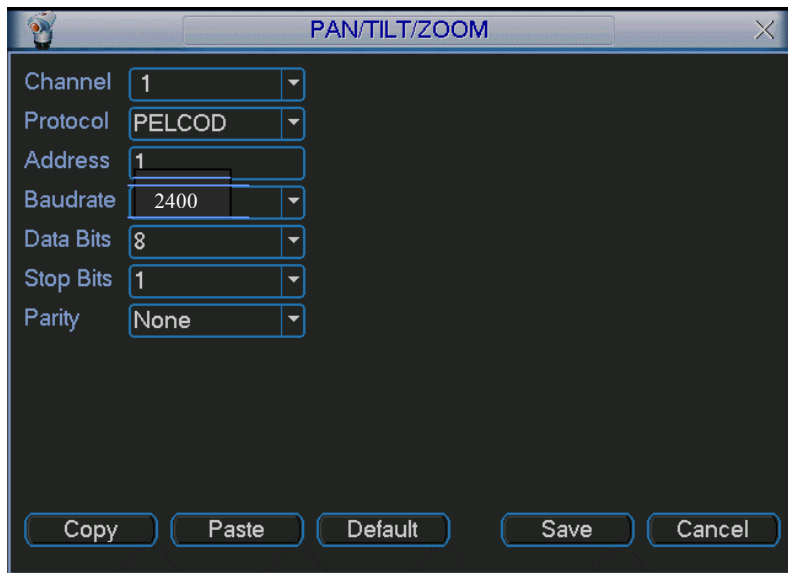

Figure 5-14

### 5.3.9 Display

Display setup interface is shown below. See figure 5-15.

**Transparency:** Adjust transparency. The value ranges from 128 to 255.

**Channel name:** Change channel name. Please note that all modifications here only apply to the DVR local end. You also need to open web or client end to refresh channel name also.

**Time display:** Select display time or not when system is in playback mode.



**Channel display:** Select display channel name or not when system is in playback mode.

**Overlay information:** System displays some information on the screen for your reference.

**Display mode:** Select from the dropdown list: self-adaptive/VGA/TV.

**Enable tour:** Activate tour function.

**Interval:** Input interval value here. The value ranges from 5-200 seconds. In tour process, you

can use mouse or click Shift to turn on window switch function.  Stands for opening switch function,  stands for closing switch function.

**View 1/4/9/16:** DVR supports 1/4/9/16 window tour depending on machine channels available.

Please highlight icon  to select the corresponding function.

After completing setup click save button and system will return to the previous menu.

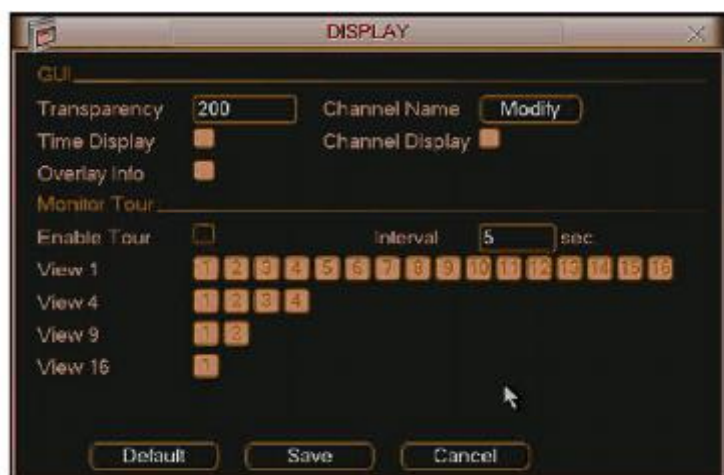



Figure 5-15

### 5.3.10 Default

Click default icon to display dialogue box. You can highlight  to restore default factory setup. See Figure 5-16.

- Select all
- General
- Encode
- Schedule
- RS232
- Network
- Alarm
- Detect
- Pan/tilt/zoom
- Display
- Channel name



Please highlight icon  to select the corresponding function.

After setup please click the save button and system will return to the previous menu.

#### **Warning!**

System menu colour, language, time display mode, video format, IP address, user account will not maintain previous setup after default operation!

### 5.4 Search

Please refer to chapter 4.3 Search.

### 5.5 Advanced

Double click advanced icon in the main window and the interface below is displayed. See figure 5-17. There are total seven function keys: HDD management, alarm output, alarm input, manual record, account, auto maintain, and TV adjust.

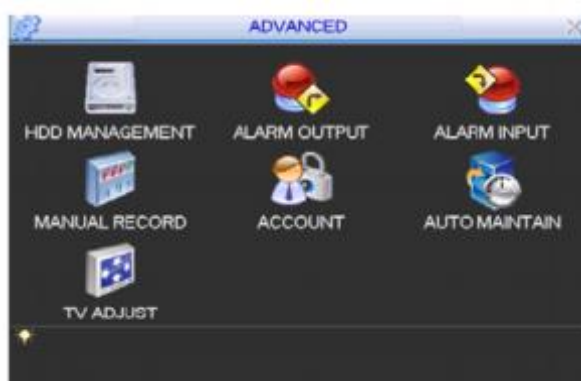

Figure 5-17

### 5.5.1 HDD Management

Here is where you implement hard disk management. See Figure 5-18.

You can set the mode for each hard disk from the dropdown list.

When you use the redundant backup function, you can set one or more redundant HDD(s). Please note you need to set at least one read-write disk, otherwise system will not record video. For detailed information you can refer to chapter 4.4 Schedule.

After setup complete please click save button. The system will need rebooting to save these changes.



Figure 5-18

Click alarm set button, the interface is shown as below. See figure 5-19.

Please highlight icon  to select the corresponding function.

You can enable one or more alarm setups. The lower limit ranges from 1% to 99%. Alarm channel number ranges from 1 to 6. Delay value is from 0 to 240 seconds.

Please note when HDD capacity is not full system only alarms once!

After setup click the OK button and system returns to the previous menu.



Figure 5-19

### 5.5.2 Alarm Output

This is where you set the alarm output. See Figure 5-20.

Please highlight icon to select the corresponding alarm output.

After setup please click OK button and system returns to the previous menu.



Figure 5-20

### 5.5.3 Alarm Input

Please highlight icon  to select the corresponding input channel.

After setup click the OK button and system goes back to the previous menu. See figure 5-21.



Figure 5-21

### 5.5.4 Manual Record

Please refer to chapter 4.2.2 manual record.

### 5.5.5 Account

This is where you set the Users and passwords. See figure 5-22.

You can do the following:

- Add new user
- Modify user
- Add group
- Modify group
- Modify password.

For account management please note:

- System account adopts two-level management: group and user. No limit to group or user settings.
- For group or user management, there are two levels: admin and user.
- The user name and group name can consist of eight bytes. One name can only be used once. There are four default users: admin/888888/666666 and hidden user “default”. Except for user 666666, all users have administrator rights.
- Hidden user “default” is for system interior use only and cannot be deleted. When there is no login user, the hidden user “default” automatically logs in. You can set some rights such as monitor for this user so that you can view some channel views without logging in.
- One user should belong to one group. User rights cannot exceed group rights.

- Reusable function: This function allows multiple users to use the same account to login. After setup please click save button and system returns to the previous menu.



Figure 5-22

### 5.5.6 Auto Maintain

Here you can set auto-reboot time and auto-delete old files setup. See figure 5-23. You can select required option from dropdown list. After setup click on the save button and the system returns to the previous menu.

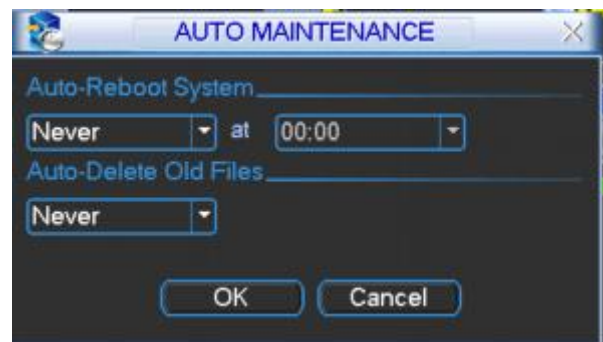

Figure 5-23

The option to auto reboot can cause problems if power cuts are a frequent problem. It is recommended that the NEVER option is set. The automatic deletion of old files is not necessary if the option to put the system into OVERWRITE mode in the General menu is set.

### 5.5.7 TV Adjust

This is for adjusting the TV output setup. See figure 5-24. Please drag slide bar to adjust each item. After setup click the OK button and system returns to the previous menu.



Figure 5-24



### 5.5.8 Video Matrix (Optional)

Some series DVRs have the matrix and loop outputs.

#### 5.5.8.1 Loop outputs

They are just the same with video distributors. There are 4/8/16-ch video loop outputs from our DVR. The DVR video output can connect with other devices such as TV walls, analog matrix and so on.

#### 5.5.8.2 Matrix outputs

The matrix outputs can be used to build TV walls and tour and display the cameras one by one.

#### 5.5.8.3 Rear Panel Connection

The rear panel is shown as below. See figure 5-25.

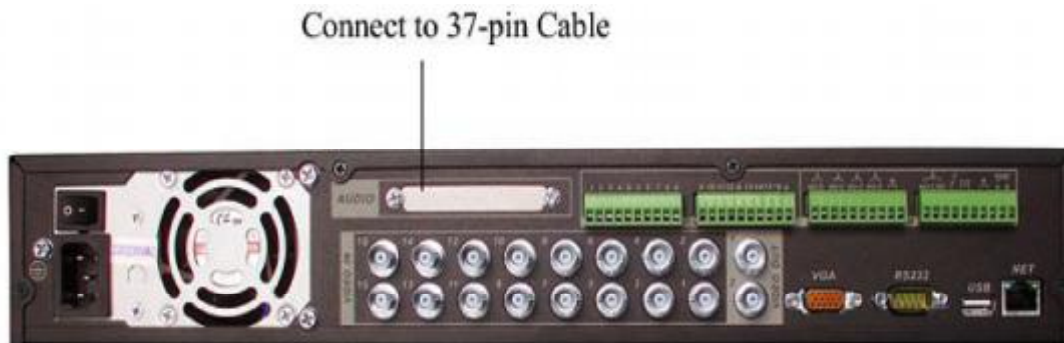

Figure 5-25

#### 5.5.8.4 37-pin cable introduction

There are three colors cable. See figure 5-26.

- Black: for loop outputs, there are 16-ch loop outputs
- Blue: for matrix outputs, there are 4-ch matrix outputs
- White: for bi-direction talk, one is for audio in and the other is for audio out.



Figure 5-26

### 5.5.8.5 Matrix setup (Optional – depends on facilities available on DVR).

#### 5.5.8.5.1 Enter Video Matrix Interface

In the menu, from “Advanced” to “Video Matrix”. You can see an interface is shown as in figure 5-27.



Figure 5-27

#### 5.5.8.5.2 Right Mouse Menu

In one-window display mode, right click mouse to select “Video Matrix”. See figure 5-28.

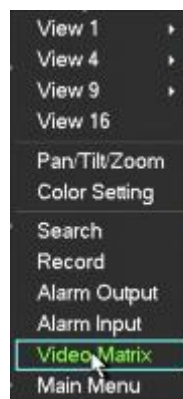

Figure 5-28

### 5.5.8.6 Video Matrix Interface and Application (not available on all models)

The video matrix interface is shown as in figure 5-29.

You can set each channel. The function consists of two types



Figure 5-29

### 5.5.8.6.1 Single Tour

Enable tour function. Then set interval time and select corresponding cameras. You can select “ALL” to tour between all channels.

Note: ”- -“means that there is no alarm activation tour.

### 5.5.8.6.2 Alarm Tour

Select the “alarm in” channel number from the dropdown list. If there is an alarm signal from the channel selected, the matrix output will go to tour as you set the “Alarm” setting (Main Menu->Setting->Alarm). See Figure 5-30.

Alarm tour has higher priority than single tour during this period so the single tour will stop. After alarm activation tour, the matrix output will continue the single tour.



Figure 5-30

### 5.5.8.7 Examples

#### 5.5.8.7.1 Example one

In Figure 5-31, matrix outputs”1”, “3”, “4” tour between all cameras of the DVR.

Matrix output 2 tours between “CAM1, CAM6 and CAM7” of the DVR. The interval is five seconds.



Figure 5-31

### 5.5.8.7.2 Example two

In Figure 5-32, when alarm occurs in channel one, the activated matrix output one begins touring between CAM1, CAM3 and CAM4 of the DVR until alarm activation tour stops.



Figure 5-32

## 5.6 Information

This menu is for viewing system information. There are a total of five options: HDD (hard disk information), BPS (data stream statistics), Log, Version, and Online Users. See figure 5-33.

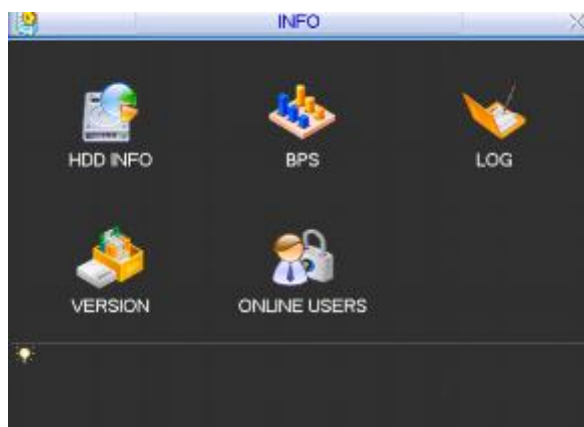

Figure 5-33

### 5.6.1 HDD Information

This lists hard disk type, total space, free space, video start time and status. See figure 5-34.

**Note:**

Please remove the failed hard disk before you add a new one.

If there is a hard disk conflict please check hard disk time and system time are identical. If not then go to the Setting menu and then General to modify system time. Finally reboot the system to resolve this problem.

In IDE information column, O means okay, X means error occurred and — means there is no disk.

The serial number after the disk information such as O, means it is the current working disk. If disk is damaged, system shows as “?”

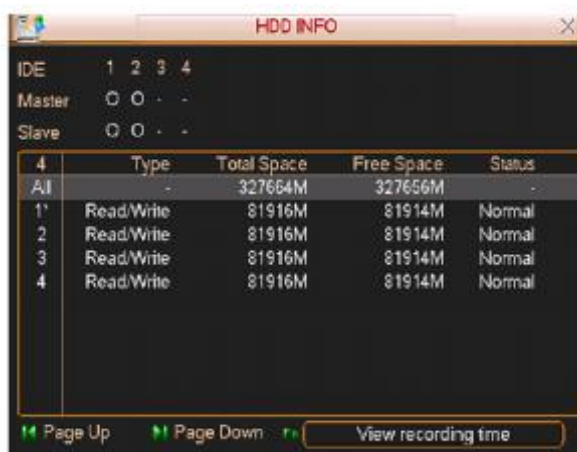

4	Type	Total Space	Free Space	Status
All	-	327664M	327656M	-
1	Read/Write	81916M	81914M	Normal
2	Read/Write	81916M	81914M	Normal
3	Read/Write	81916M	81914M	Normal
4	Read/Write	81916M	81914M	Normal

IDE    1   2   3   4  
Master    O   O   -   -  
Slave    O   O   -   -

Page Up    Page Down    View recording time

Figure 5-34

### 5.6.2 BPS

Here is where you view current video data stream (KB/s) and occupied hard disk storage (MB/h). See figure 5-35.

Channel	Kb/S	MB/H	Wave
1	1747	383	
2	1736	381	
3	1736	381	
4	1736	381	
5	1736	381	
6	1736	381	
7	1736	381	
8	1736	381	
9	1736	381	
10	1736	381	
11	1736	381	
12	1736	381	
13	1736	381	
14	1736	381	
15	1736	381	
16	1736	381	

Figure 5-35

### 5.6.3 Log

This lets you view the system log file. System lists the following information. See figure 5-36.

Type	Start Time	End Time	Log Time	Event
All	2006 - 06 - 16 00 : 00 : 00	2006 - 06 - 17 00 : 00 : 00		
1			06-06-16 15:53:31	Shut down at [06-06-08 19:28:49]
2			06-06-16 15:53:31	Reboot with Flag [0x01]
3			06-06-16 16:06:47	Shut down at [06-06-16 15:56:11]
4			06-06-16 16:06:47	Reboot with Flag [0x01]

Figure 5-36

### 5.6.4 Version

This is where you can view version information. See figure 5-37.

- Channel:
- Alarm in:
- Alarm out:
- System version:
- Baud rate:
- Start upgrade

Channels	16
Alarm In	16
Alarm Out	6
System	Version 1.28
Build Date	2006-05-24

**UPGRADE**

If you need to upgrade system now, please insert USB disk, then press the start button to start upgrade. Don't shut down the power during upgrade!

Figure 5-37

### 5.6.5 Online Users

This is where you manage online users. See figure 5-38.

You can disconnect one user or block one user if you have correct system rights.

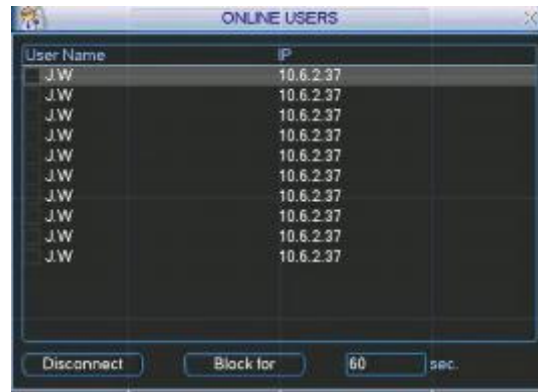

Figure 5-38

### 5.7 Exit

Double click exit button and system displays a dialogue box for you to select.

See figure 5-39.

**Logout menu user:** Log out menu. You need to input password when you login the next time.

**Restart application:** Reboot DVR.

**Shutdown:** System shuts down and turns off power.

**Restart system:** System begins rebooting.

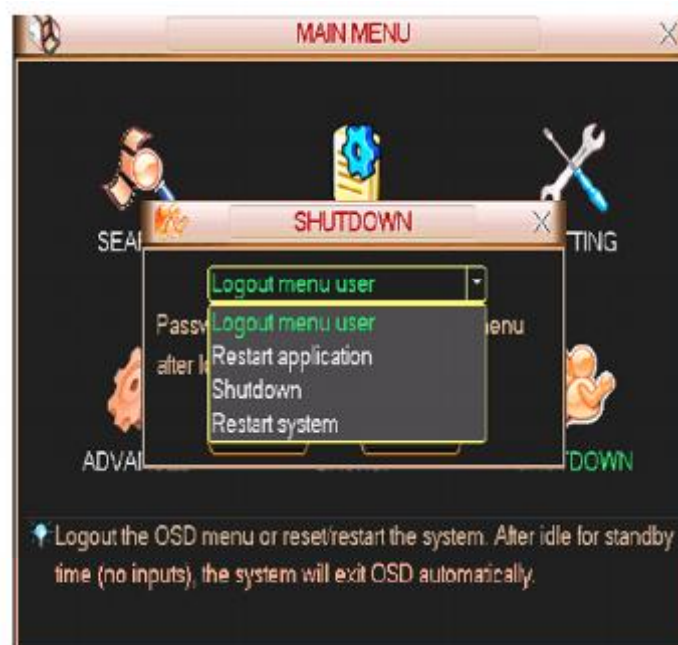



## 6 About Auxiliary Menu

### 6.1 Go to Pan/Tilt/Zoom Menu

In the one-window surveillance mode, right click mouse (click “fn” Button in the front panel or click AUX key in the remote control). The interface is shown below: See Figure 6-1.



Figure 6-1

Click Pan/Tilt/Zoom and the interface in Figure 6- will be displayed.

Here you can set the following items:

- Zoom
- Focus
- Iris



Click icon  and  to adjust zoom, focus and Iris.









Figure 6-3

In Figure 6-, please click direction arrows (See **Error! Reference source not found.** ) to adjust PTZ position. There are a total of eight direction arrows. (Please note there are only four direction arrows in DVR front panel.)



### 6.1.1 3D Intelligent Positioning Key

Note the following for reference.

Name	Function key	function	Shortcut key	Function key	function	Shortcut key
Zoom		Near	▶		Far	▶▶
Focus		Near	◀		Far	▶▶
Iris		close	◀		Open	▶

### 6.2 Preset /Patrol / Pattern /Border Function

In Figure 6- click the set button. The interface is shown as below:

Here you can set the following items:

- Preset
- Patrol
- Pattern
- Border



Figure 6-2

In Figure 6-, click page switch button and you will see an interface as in Figure 6-3.

Here you can activate the following functions:

- Preset
- Tour(Patrol)
- Pattern
- Aux on
- Aux off
- Auto scan
- Auto pan
- Light on



Figure 6-3

### 6.2.1 Preset Setup

**Note:** The following setups are usually operated in Figure 6-, Figure 6-2 and Figure 6-3.

In Figure 6-, use eight direction arrows to adjust camera to the correct position.

In Figure 6-2, click preset button and input preset number.

The interface is shown as in ..

Add this preset to one patrol number



Figure 6-4

### 6.2.2 Activate Preset

In Figure 6-3 please input preset number in the No. blank, and then click the preset button.

### 6.2.3 Patrol Setup

In Figure 6-2, click patrol button. The interface is shown in ..

..

Input preset number and then add this preset to one patrol.



Figure 6-5

### 6.2.4 Activate Patrol

In Figure 6-3, input patrol number in the No. blank and then click the patrol button

### 6.2.5 Pattern Setup

In Figure 6-2, click pattern button and then click the begin

button. The interface shows like that in .. Please go to

Figure 6- to modify zoom, focus, and iris. Go back to .. and click end button. You can memorise all these setups as pattern 1.



Figure 6-6

### 6.2.6 Activate Pattern Function

In Figure 6-3 input mode value in the No. blank, and then click pattern button.

### 6.2.7 Border Setup

In Figure 6-2, click the border button. The interface is shown as in Figure 6-7. Please go to Figure 6-, use direction arrows to select camera left limit, and then please go to Figure 6-7 and click left limit button. Repeat the above procedures to set right limit.



Figure 6-7

### 6.2.8 Activate Border Function

In Figure 6-3, click auto scan button, the system begins auto scan. Correspondingly, the auto scan button changes to stop button. Click stop button to terminate scan operation.

### 6.3 Dome Menu Control

In Figure 6-6, click page switch button, the interface is shown as below. See Figure 6-11. Click menu to enter dome menu. The direction arrows here are to control dome menu. Click page switch button, system goes back to Figure 6-2.



Figure 6-11

## 7 WEB CLIENT OPERATION

Please note: All the operations here are taking a 16-ch DVR as an example. There might be slight differences with the interface in different DVR series.

### 7.1 Network Connection

Before web client operation, please check the following items:

- Network connection is correct
- DVR and PC network setup is correct. Please refer to network setup (main menu->setting->network)
- Use order ping **\*\*\*.\*\*\*.\*\*\*.\*\*\***(\* DVR IP address) to check connection is OK or not. Usually the return TTL value should be less than 255.

### 7.2 Login and Logout

Open IE and input DVR address in the address column. For example, if your DVR IP is 10.1.27.200, then please input `http:// 10.1.27.200` in IE address column.

System displays warning information to ask you whether to install `webrec.cab` control or not. Please click yes button.

If you can't download the ActiveX file, please modify your settings as follows. See Figure 7-1.

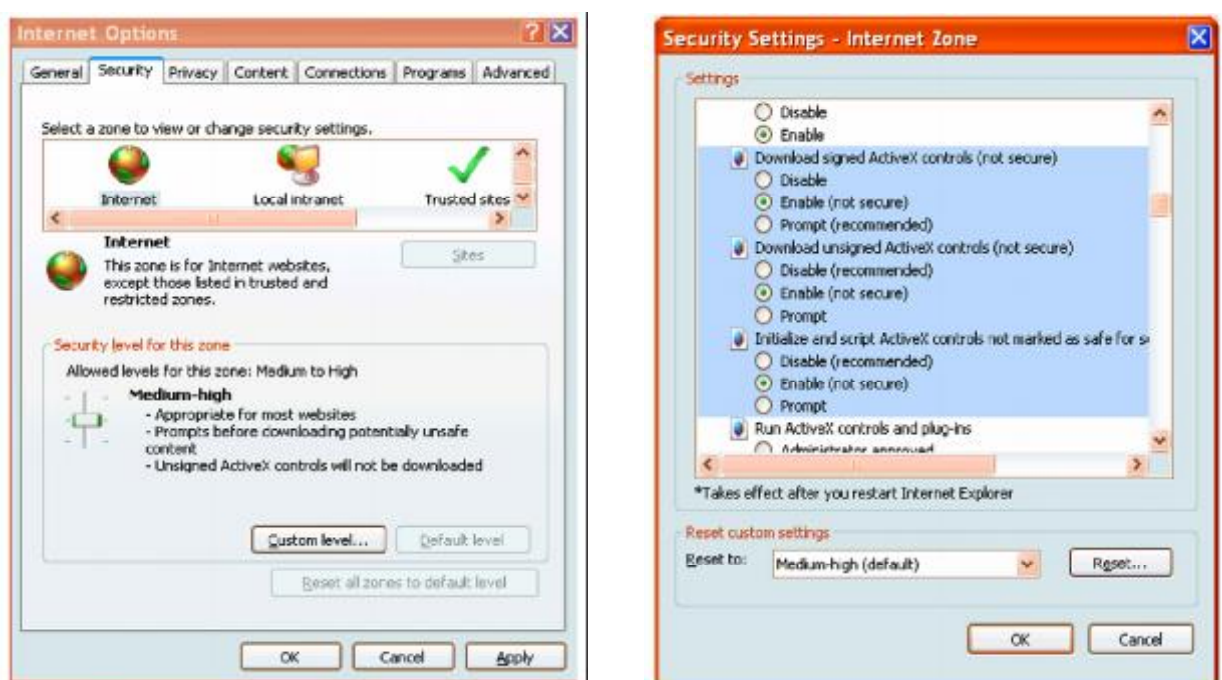

Figure 7-1

After installation the interface shown below is displayed. See Figure 7-2.

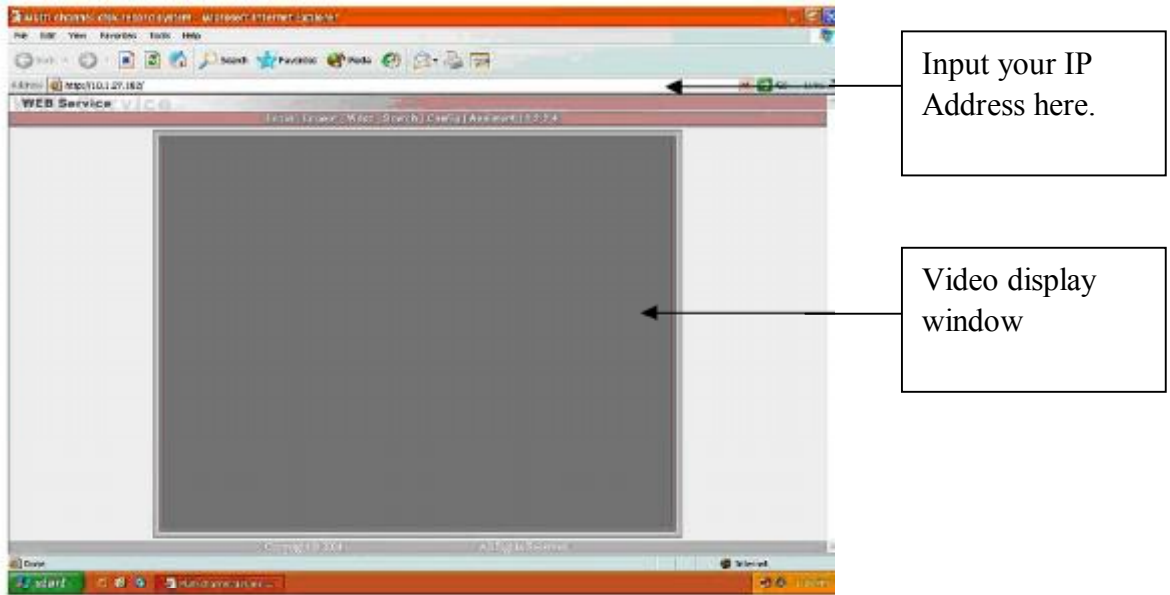

Figure 7-2

There are six function keys: login, logout, video, search, configuration and assistant. See Figure 7-3.

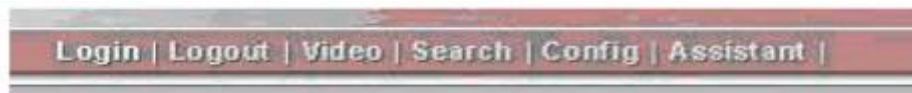

Figure 7-3

Click login and the following interface will be displayed. See Figure 7-4. Please input your user name and password. Default factory name is admin and password is admin. Note: For security reasons, please modify your password after you first login.



Figure 7-4

### 7.3 Go to Real-time Monitor Mode

There are three ways for you to go to real-time monitor mode.

Select the channel number besides function key. See Figure 7-5.



Figure 7-5

In Figure 7-5, click “video” button then select real-time monitor and then click the channel number you want to view.

In the main window, right click mouse, select the channel you want to view from real-time monitor.

### 7.4 Video (Right Mouse Menu Operation)

After login, click video button or right click mouse, the interface is shown as below. See Figure 7-6.

**Real-time monitor:** Choose the channel you want to view.

**Start dialogue:** Click here to begin audio talk.

**Multi-camera preview:** System supports various video preview modes.

**Decode quality:** There are a total of four levels: general, good, better and best.

**Playback control bar:** This is where you control playback.

**PTZ control:** Here is where you control the PTZ. Before operation please check you have selected the right protocol for the DVR

**Volume adjustment:** This is where you adjust the PC audio volume.

**Alarm setting:** This is where you set alarm input and alarm output.

**Network data flux:** This is where you view current data flux

**Full screen:** Enter into full screen display mode.

**Video zoom:** There are five options:20%,40%,60%,80%,100%

**Video windows:** Support 1/2/4 window display mode.



Figure 7-6



### 7.4.1 Real time Monitor

Select the channel you want to implement real-time monitor.

### 7.4.2 Multi-camera Preview

This is where you select view modes: 1/2/3/4/9/16. (According to model purchased).

### 7.4.3 Start Dialog

Click this button to enable audio talk function.

### 7.4.4 Decode Quality

Select decode quality. There are four levels: general, good, better and best.

### 7.4.5 Playback Control Bar

Select playback bar when you are viewing video file. See Figure 7-7.

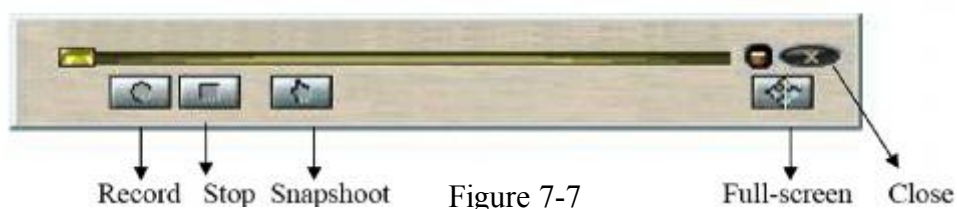

### 7.4.6 PTZ Control

Please click the corresponding direction arrow to adjust zoom, focus and iris. See Figure 7-8. Note: before you operate this function, please make sure you have properly set PTZ protocol (Main menu->Setting->Pan-tilt Zoom).

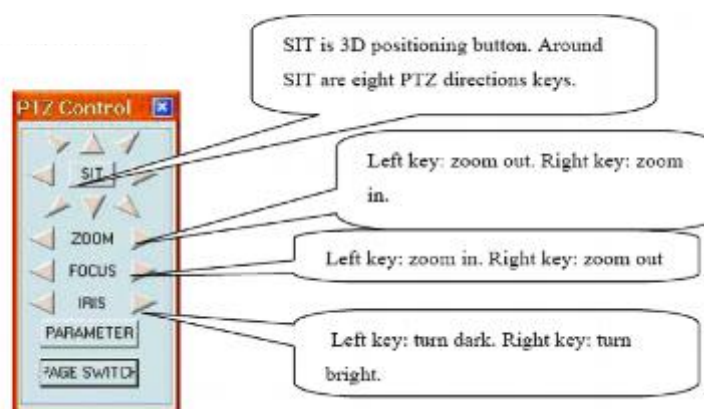

Figure 7-8

Click Parameter button in Figure 7-8 and the following interface will be displayed. See Figure 7-9.





Figure 7-9

Here is where you control direction operation. There are eight levels ranging from 1 to 8. Level 8 is the fastest speed. In Figure 7-9, click PTZ set button. You can see the following dialogue box. See Figure 7-10. You can select in the dropdown list.



Figure 7-10

#### 7.4.7 Volume Adjustment

Please drag volume bar to adjust audio level. You can draw a  $\surd$  before Mute to turn off audio. See Figure 7-11.



Figure 7-11

#### 7.4.8 Alarm Setting

Click alarm setting, where you can set alarm input and output. See Figure 7-12.

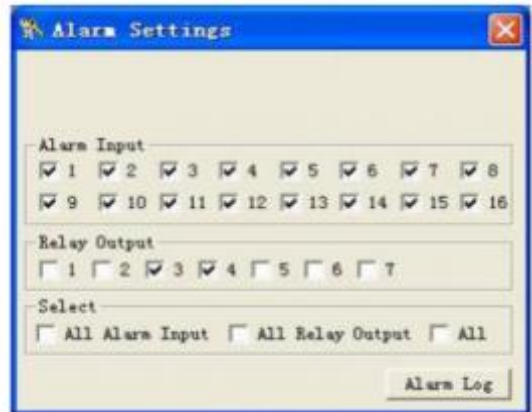

Figure 7-12

#### 7.4.9 Network Data Flux

This displays the statistics of the network transmission data flux. See Figure 7-13.



Figure 7-13

#### 7.4.10 Full Screen

There are two ways to view full screen monitor: One is to double click on the current monitor window directly; the other is to select Full screen in the right click menu items. During multi-window state, choose one of the windows and double click for full screen display.

#### 7.4.11 Resize Video

There are four display ratios for you to choose: 40%, 60%, 80% and 100%. See Figure 7-14.

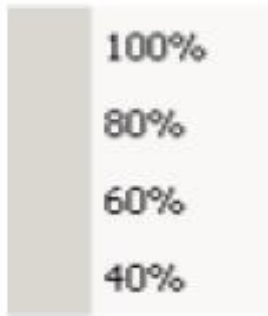

Figure 7-14

### 7.4.12 Video Windows

This allows the display mode to be selected. See Figure 7-15.



Figure 7-15

## 7.5 Search

Select video type, channel number and time of the file you want.

Click search button and the interface below is displayed. See Figure 7-16

Use the page up/down key to view the search results. If you double click file name, you can view the file and the system will automatically backup the image in your installation directory.



Figure 7-16

In the search result interface, you can select one or more files to download to your local PC.

The playback bar is shown as below. See Figure 7-17.

- 1: Save
- 2: Stop
- 3: Snapshot
- 4: Fast Backward
- 5: Play
- 6: Pause
- 7: Fast play
- 8: Hide
- 9: Full-screen
- 10: Close

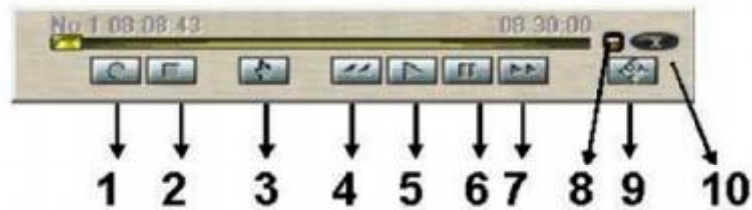

Figure 7-17

### 7.5.1 Download

You can select one or more files you want to download and then click download button. System displays a dialogue box asking you specify directory. See Figure 7-18.

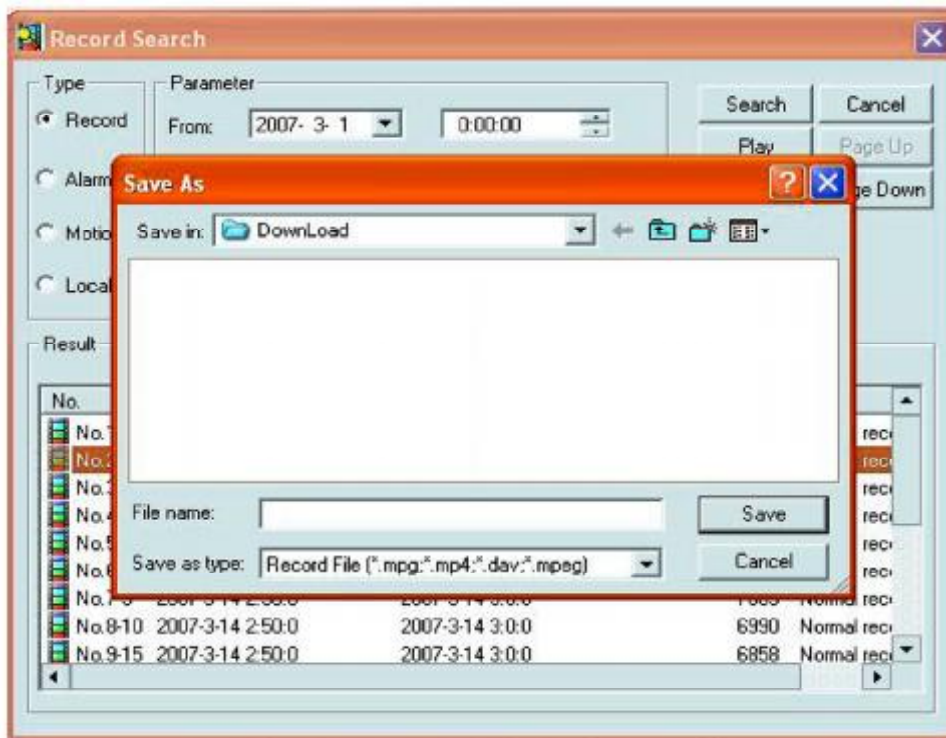

Figure 7-18

Then you can input file name and click save to backup file in your local pc. During the download process, there is a process bar for you reference. See Figure 7-19.

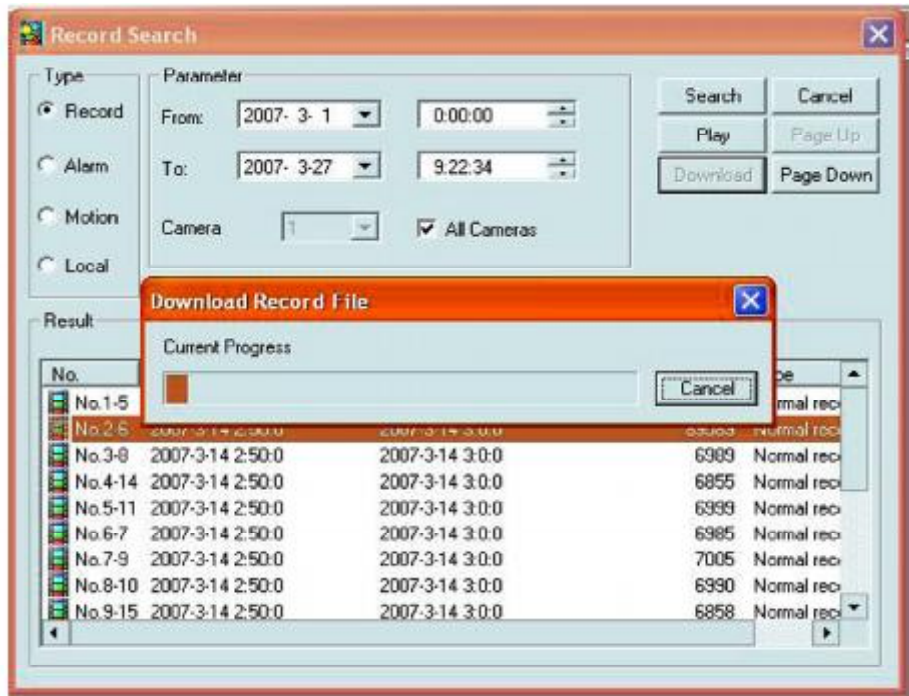

Figure 7-19

The Download file name is usually made up of: File name +Channel No +Date + Time. File extension name is .dav.

For example: file name a-0180021205071028.mp4 means:

**01**: channel 1

**80021205**: 5th December 2008

**071028** :7 hours 10 minutes 28 seconds.

## 7.6 Configure

Click configure button. There are a total of seven function keys. See Figure 7-20.

**Image**

**Alarm**

**Motion detection**

**Network**

**Video parameter**

**General**

**Schedule**



Figure 7-20

## 7.6.1 Load and Save Configuration

### 7.6.1.1 Save configuration

Click export configuration button in Figure 7-20. You can save current configuration to a directory. The file extension name is CFG. See Figure 7-21.

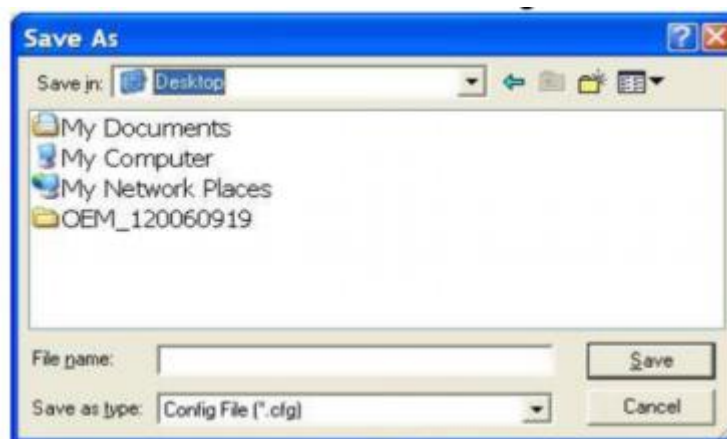

Figure 7-21

### 7.6.1.2 Load configuration

Click import configuration button in Figure 7-20. Tick the checkbox to load your backup file. See Figure 7-22. Click Ok button and then select file with extension name of .CFG. Now you have updated the system setup as per the saved configuration file. Note that you can load the configuration so that the IP address, Port and remote address are not loaded.



Figure 7-22

### 7.6.2 General

Click the General button and the interface below is displayed. See Figure 7-23. Here you can select file length (**Pack Duration**) and choose to **Overwrite** previous files or stop recording when the hard drive is full. You can also select channel number, protocol, address and baud rate to control the lens or PTZ.

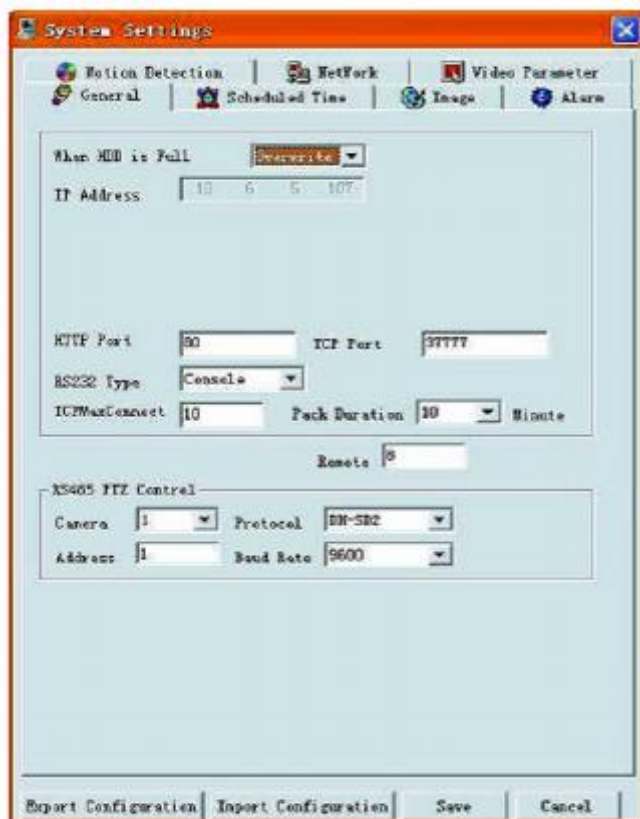

Figure 7-23



### 7.6.3 Schedule

Click the Schedule button and the interface below is displayed. See Figure 7-24.

Select the camera number, day of the week or All and tick the column against the required time period to denote whether you want a continuous recording (Record), a motion detection recording (Motion) or an Alarm recording (Alarm).

You may select up to six time periods in any 24 hour period. If you are only selecting one time period then enter 00:00 – 24:00 in time period 1. Only time periods clicked are selected.

Special Note: The Save Channel button at the top of this menu is for saving changes made to this menu. The Save at the bottom of the menu saves the changes into the configuration file for reloading from the configuration file.



### 7.6.4 Image

Click the Image button and the interface below is displayed. See Figure 7-25.

Here you can select the image quality, video type and resolution for each channel. You can select from the dropdown lists.

**Camera:** Camera number

**FPS (PAL):** Frames per second: 1/2/3/6/12/25. (Some series DVR only support 25f/s PAL.)

**Data:** There are two data modes: **CBR/VBR**. Always set to VBR for network access.



**Quality:** There are six levels. The different data flux occupies different bandwidths and the transmission image qualities are also different. Among them, level 6 needs the widest bandwidth and can reveal the best image quality. Please note your setup here only applies for image quality in web or client end.

**Video:** Compression mode: MPEG4

**Resolution:** There are several resolutions for you. You can select from the dropdown list.

**Alarm when video loss:** You can enable or disable alarm function when alarm loss occurs.

**Network transmission protocol:** Select protocol for network playback and monitor. You can select from the dropdown list.

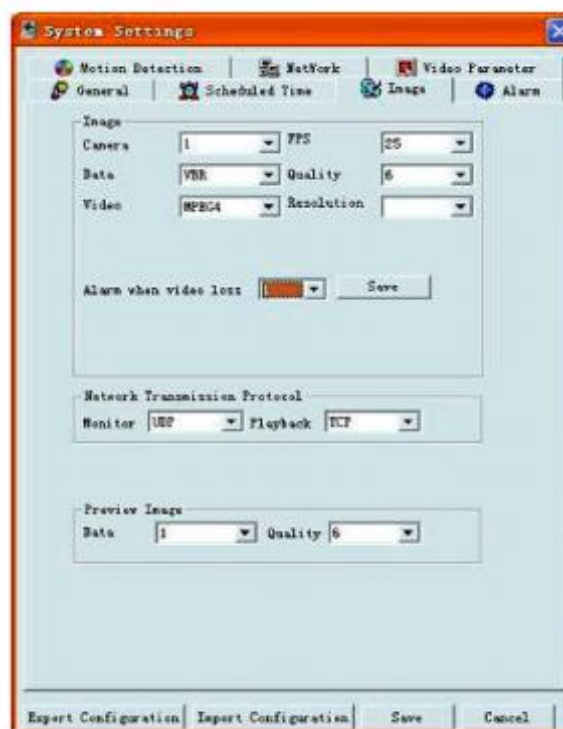

Figure 7-25

### 7.6.5 Alarm

This is where you select the record channel and output port. See Figure 7-26.

There are two alarm types: normally open or normally closed.

Delay time ranges from 10 to 300 seconds.

Click on the check box to enable record camera and output port.

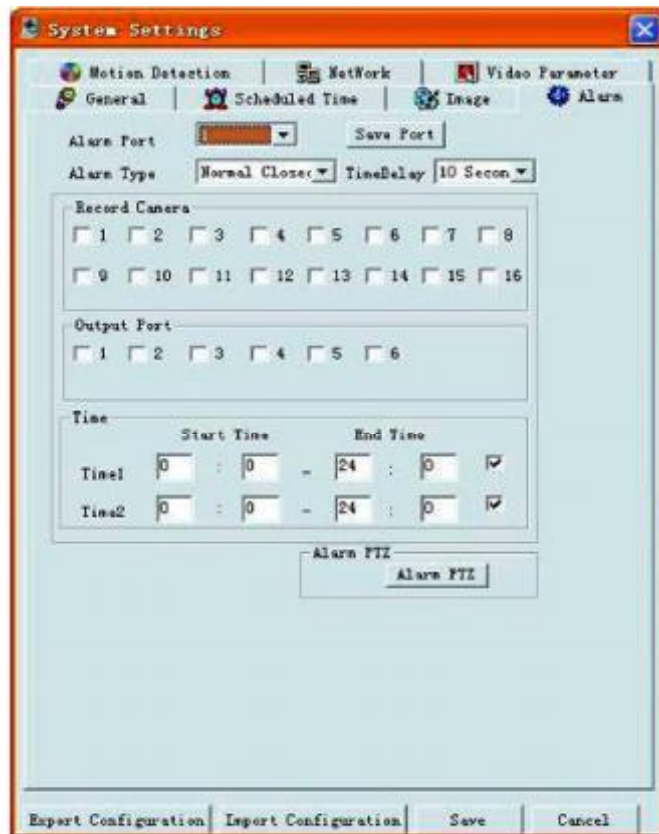

Figure 7-26

In Figure 7-26 click alarm PTZ button and you will see the following interface. See Figure 7-27.

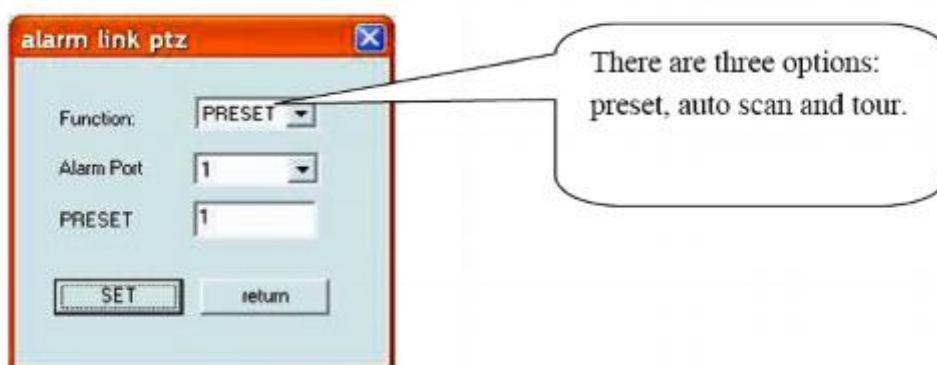

Figure 7-27

### 7.6.6 Motion Detection

Motion detection will take effect exclude the time you set to schedule recording. See Figure 7-28. The **blue** area is the selected motion detection area.

Click **Full screen** or right click mouse to view the motion detection area in full screen. After setting the area you can **Save channel** or **Clear** the area.

**Alarm output** : Here you can enable alarm output channel. Please tick the check box.

Please note if you want to set this channel as motion detection recording, you need to turn off the schedule recording setup for this channel (Main Menu->Setting->Schedule).

Figure 7-28

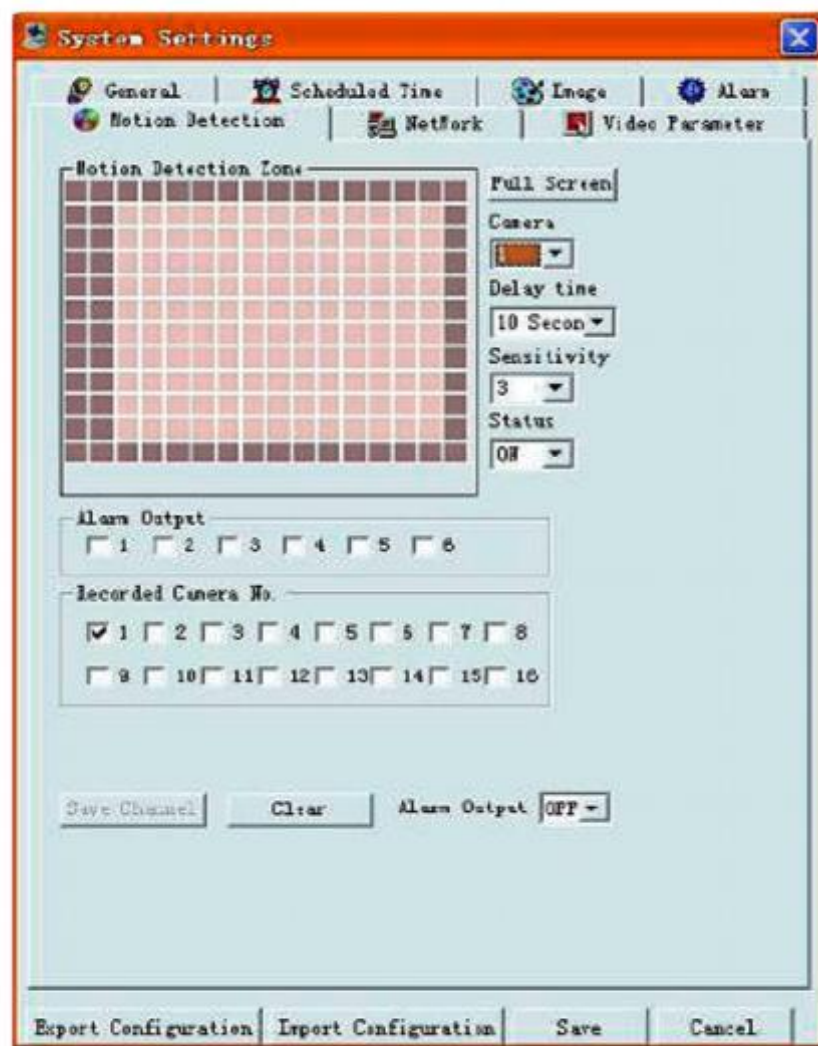

Figure 7-28

### 7.6.7 Network

The PPPoE interface is shown in Figure 7-29. As PPPoE is not used in the UK the information concerning setup is not applicable.



Figure 7-29

### 7.6.8 Video Parameter

The Video parameter setup interface is shown in Figure 7-30. Before setup please select channel number first

**Audio enable:** You can select to close or open audio.

**Auto white balance:** You can select to close or open white balance.

**Image:** You can adjust colour, contrast, brightness, saturation etc.

After completing all channels setup, click the “save” button to save all configurations.



Figure 7-30

## 7.7 Assistant

Click the Assistant setting and the interface below is shown. See Figure 7-31. There are nine function keys. Please note the Matrix control item only applies to some special models.

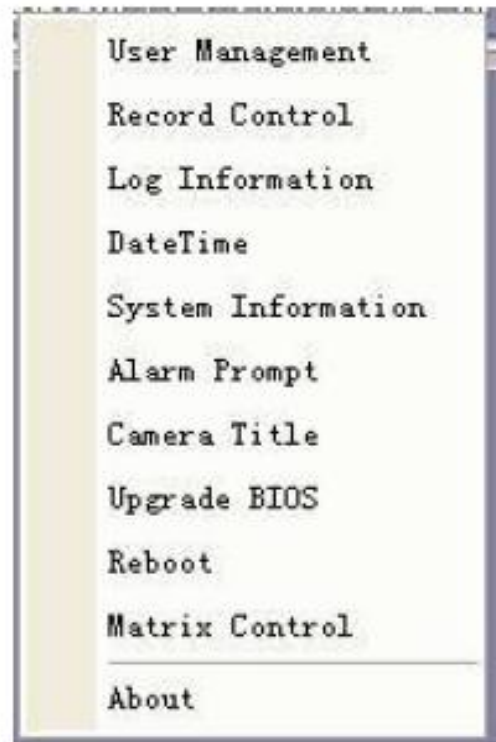

Figure 7-31

### 7.7.1 User Manage

This is for managing users and user groups. See Figure 7-32. You can click '+' to see the whole group list.



Figure 7-32

### 7.7.1.1 Add Group

Click “add group” button to input group name. See Figure 7-33.

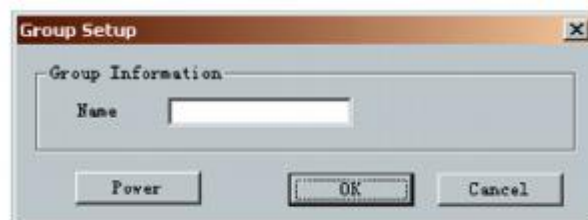

Figure 7-33

Click “Power” button to set group power.

Click “Save” button to save configuration

### 7.7.1.2 Delete Group

Click “Delete Group” button, the interface is shown as in Figure 7-34.

**Note: You can only delete empty group (E.g.: There is no user in current group).**



Figure 7-34

### 7.7.1.3 Modify Group

Click modify group, the interface is shown in Figure 7-35. You can modify group name and then click “power” button to set rights for the whole group.



Figure 7-35

#### 7.7.1.4 Add User

Click “Add User” button and the interface below is shown. See Figure 7-36. Input user name, password, and then input password again to confirm.



Figure 7-36

#### 7.7.1.5 Power

When you add new user or new group (such as in Figure 7-33, Figure 7-36. ), click “power” button, the interface is shown as in Figure 7-37. This is where you set user’s power. There are three power groups: main control power/monitor power/playback power. You can click the checkbox to enable corresponding function.

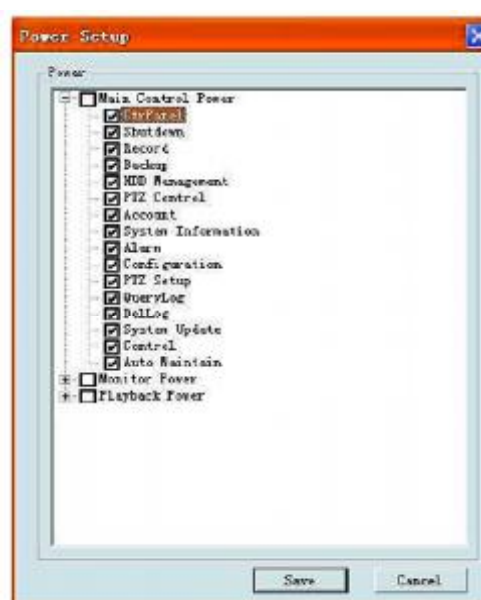

Figure 7-37

### 7.7.1.6 Modify user

Select one user and then click the modify user button and the interface as shown in Figure 7-38 is displayed. Here you can modify user name.



Figure 7-38

### 7.7.1.7 Delete user

Select one user and then click “delete user” button, you can see the following dialogue box. See Figure 7-39. Click “Yes” to delete current user.

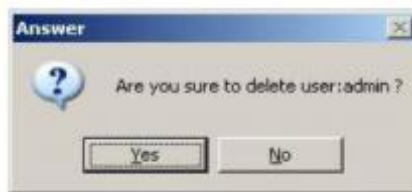

Figure 7-39

### 7.7.2 Record Control

Click “record control” button and the interface below is displayed. See Figure 7-40. You can select mode for each channel.

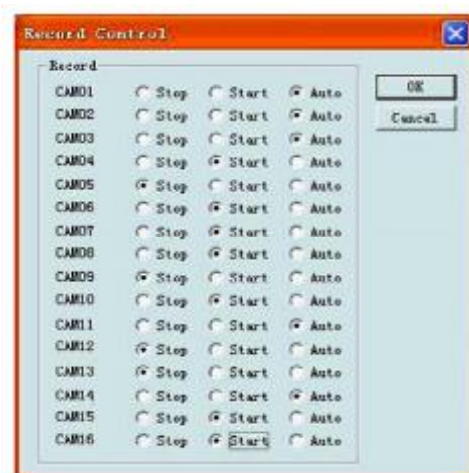

Figure 7-40

### 7.7.3 Log Information

System can automatically backup all operations in log information.

You can click this button to view detailed information. See Figure 7-41.



Once you click save log button, the log files will be automatically saved in the root directory such as “C:\ as a text file (e.g.: C:\ 10.1.27.193-log.txt)

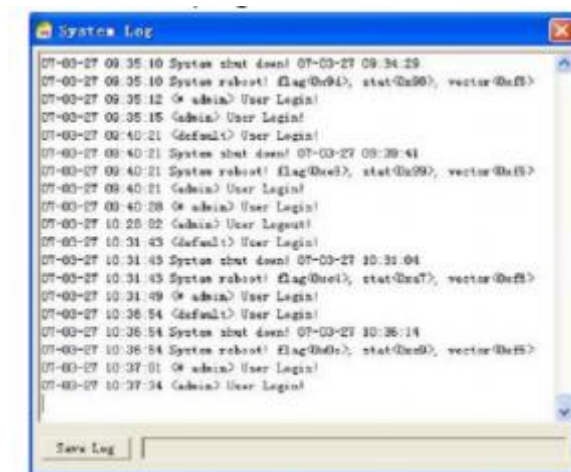

Figure 7-41

### 7.7.4 Date and Time

Here you can modify system date and time. See Figure 7-42.



Figure 7-42

### 7.7.5 System Information

Here you can view the basic system information. See Figure 7-43.

The following functions are available:

Turn on/off audio

Select video type

Select preview image

Preview image

Close or open auto tour monitoring

View network data flux



Figure 7-43

### 7.7.6 Alarm Prompt

This is where you can choose different alarm audio sounds. See Figure 7-44.

Here you can select system AlarmSound.wav file from folder system32 as your audio sound.



Figure 7-44

### 7.7.7 Channel Name

This modifies the channel name.

The revised channel names will be displayed on the screen.

The default setting of the channel name is Channel No.1 to Channel No.16.

See Figure 7-45.

Please note when you modify channel name in DVR end, this modification does not apply to web end.



Figure 7-45

### 7.7.8 Upgrade BIOS

Click upgrade BIOS button and the interface shown below is displayed. See Figure 7-46.

Open the BIOS file and then click the send BIOS button.

During the upgrade process, there is a process bar for your reference.



Figure 7-46

### 7.7.9 Reboot

Click reboot button and system displays a warning dialogue box to alert you.

See Figure 7-47.

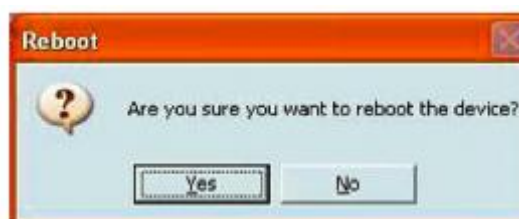

Figure 7-47

### 7.7.10 Matrix (Only applies to some DVR models)

Matrix control interface is shown as in Figure 7-48.

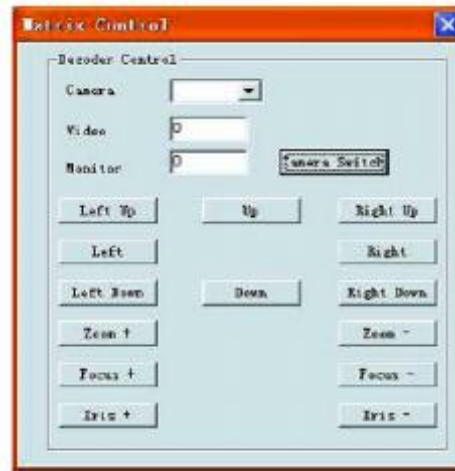

Figure 7-48

### 7.7.11 About

This is where you view basic system information. See Figure 7-49.



Figure 7-49

### 7.7.12 Mail

In the Assistant setup, select email function. You can see the interface as shown in Figure 7-50. Here you can input server IP, receiver, email title etc.

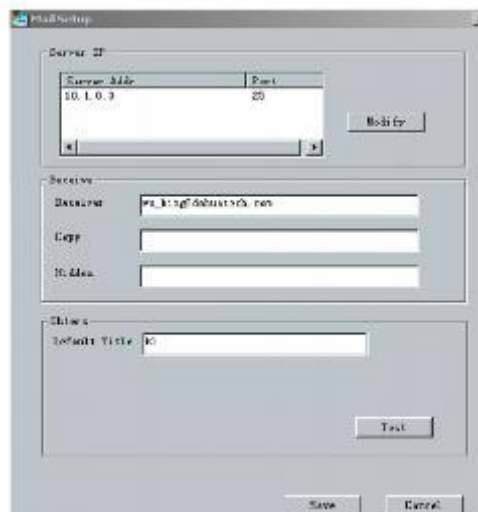

Figure 7-50

Now you can set alarm information for future upload.  
 For motion detection, you can enable Email function in detection interface.  
 For external alarm, you can enable Email function in alarm setup interface.  
 See Figure 7-51.

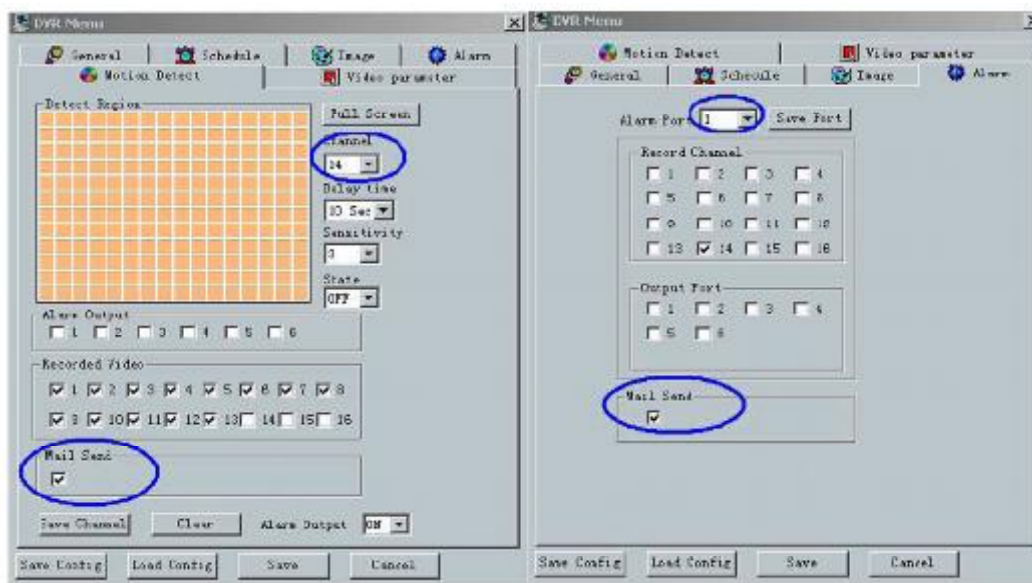

Figure 7-51

After setup, you can receive Email from client end. The Email content is shown as below:

Alarm Matter: Email Test...  
 AlarmIn Channel: 255  
 Alarm Start Date(Day/Month/Year Hour:Minute:Second): 12/12/2006 16:30:20  
 Alarm Device Name: localhost  
 Mail\_Sender IP : 10.6.3.8

In motion detection mode, you can set Email function (Enable/disable) for each channel.

The email content is shown as below.

Alarm Matter: Motion Detect

AlarmIn Channel: 2

Alarm Start Date(Day/Month/Year Hour:Minute:Second): 12/12/2006 15:5:36

Alarm Device Name: localhost

Mail\_Sender IP : 10.6.3.9

## 7.8 Un-install Web Control

There are two ways for you to un-install web control.

From start, click run and then input order `regsvr32 -u WebRec.ocx`.

Use web un-install tool “uninstall web.bat” to un-install web con

## 8 SightBoss System

The sightBoss system allows you to manage numerous DVR365s remotely.

### 8.1 Features

The sightBoss system has the following features:

- Manages devices conveniently
- Supports multiple-device connection, real-time surveillance and playback
- Device management, log review and user management
- PTZ control and device alarm, video record
- Supports multiple-device upgrade simultaneously
- E-map and network backup support

### 8.2 Environment

We recommend the following minimum PC system configuration:

#### Hardware

- CPU P4 2.0G
- Video card: supports hardware zoom such as ATI, TNT2 PRO. We recommend ATI9800 or above dual channel. 128M/128bit
- Network card: 100M

#### Software

- For client end we recommend Windows 2000 or Windows XP.

### 8.3 Overview

Multiple-client main window is shown in Figure 8-1.

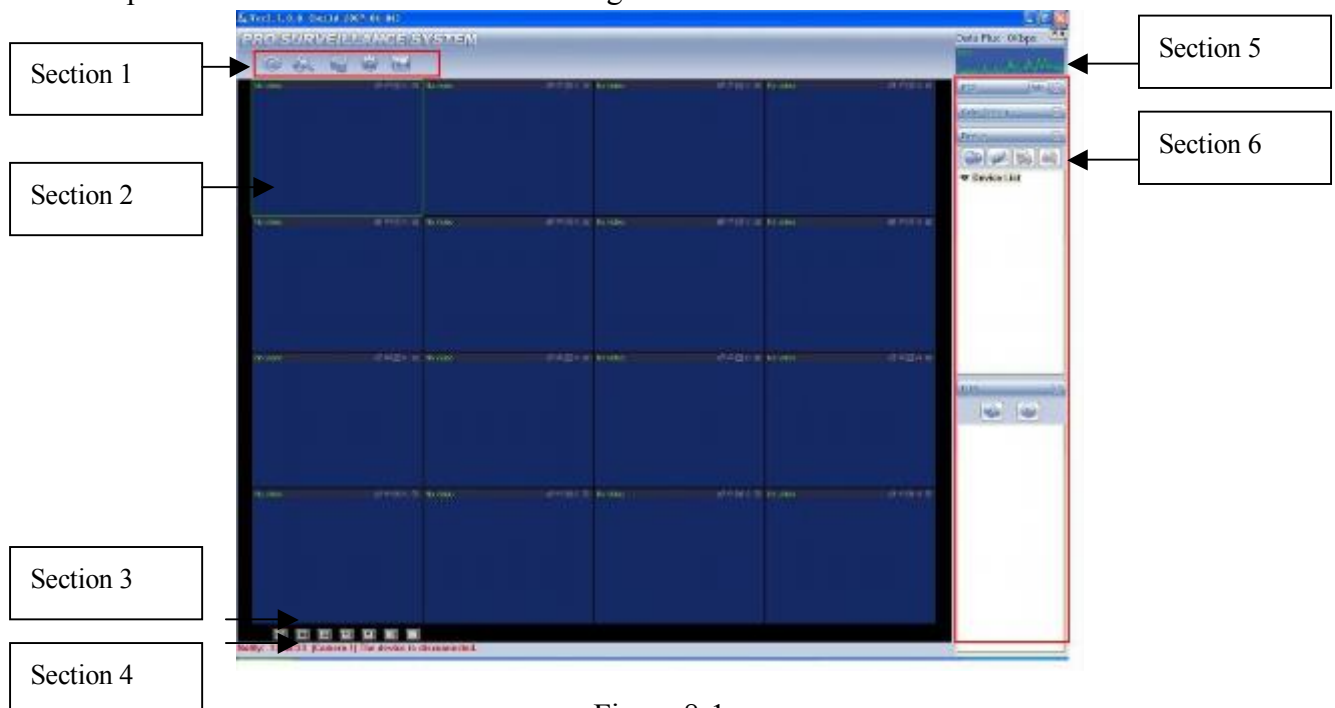

Figure 8-1

There are a total of six sections:

- Section 1: There are five function keys: monitor, record, device, system and e-map. Please refer to chapter four for detailed information.
- Section 2: View channel video.
- Section 3: Select display mode. System supports the following display modes: full-screen /single window/four-window/six-window/eight-window/nine-window/sixteen-window.
- Section 4: View current help information.
- Section 5: Display data flux and CPU status.
- Section 6: There are four function buttons: PTZ/Colour setting/Device/Plan. Please refer to chapter three for detailed information.

## **8.4 More Details**

Please refer to the SightBoss System User's Manual for more information.



## **9 Frequently Asked Questions**

### **1. DVR will not boot up properly.**

This can be due to the following:

Incorrect power supplied, poor connection or power switch damaged.

Incorrect BIOS loaded.

Hard drive malfunction or damaged data cable to hard drive.

Incompatible hard drive fitted.

Front panel error.

Damaged mainboard.

### **2. System cannot detect hard disk.**

Check that the serial ATA data cable and power cord are correctly connected.

### **3. I cannot use Schedule record function.**

Please note the recording time unit takes one day as a working unit i.e.: from 0000hrs to 2400hrs.

### **4. Record light is flashing during the whole recording procedure.**

Check the external video input signal. This problem usually happens when the inputting signal is not standard. Sometimes the reading speed of the Hard Drive is too slow. In this situation, you will need to change the hard drive.

### **5. My DVR is very hot, is there any problem?**

The DVR365 does generate considerable heat. It is very important that the environment where the unit is installed is dry and free from dust. Always ensure the unit is installed in a well-ventilated position and that air vents are not covered.

### **6. I cannot see video signal on one channel while the other channels are ok**

Check the video cable connection. Connect the camera video cable direct to the monitor to test. If there is still no signal, there may be a problem with the camera or video cable.

### **7. I cannot use my remote controller.**

Please move remote controller directly to the DVR, and then press address button. System displays address input dialogue box. Please input you remote address (default value is 008). When ACT light is on, you can use it.

### **8. I cannot control PTZ or dome**

Check RS485 connections are correctly connected.

Check system setup. Please refer to pan-tilt setup.

Protocol and Baud Rate must agree with physical PTZ setup.

### **9. I cannot login via web**

There are two conditions:

- Network connection failure

Check your DVR and PC connections are correct. Please check DVR IP address, network cable and Gateway address. Use ping facility to check PC can see DVR.

- Invalid password or username. Please check correct username and password have been specified.

### **10. When I first connect to the server video quality is poor.**

If the image returns to normal in five seconds, effect is normal.

### **11. What peripheral equipment DVR can work with?**

This DVR supports equipment such as keyboards, alarm input and output equipment and alarm servers and access control systems.

**HDD capacity (Gb) required per channel for set days**

Ch	RES.	Bit Rate	FPS	Bit Rate/kbs	Mb/h	1day	5days	10days	14days	30days
----	------	----------	-----	--------------	------	------	-------	--------	--------	--------

1	CIF	CBR	1	128	46	1	6	11	16	33
				512	74	2	9	18	25	53
				1024	74	2	9	18	25	53

2	CIF	CBR	6	128	53	1	6	13	18	38
				512	177	4	21	42	59	127
				1024	289	7	35	69	97	208

3	CIF	CBR	12	128	54	1	6	13	18	39
				512	192	5	23	46	64	138
				1024	354	8	42	85	119	255

4	CIF	CBR	25	128	58	1	7	14	19	42
				512	192	5	23	46	65	139
				1024	377	9	45	91	127	272

**HDD capacity (Gb) required per channel for set days**

Ch	RES.	Bit Rate	FPS	Bit Rate/kbs	Mb/h	1day	5days	10days	14days	30days
1	D1	CBR	6	128	78	2	9	19	26	56
2	D1	CBR	6	512	201	5	24	48	67	145
3	D1	CBR	6	1024	371	9	44	89	125	267
4	D1	VBR	6	1024 (4)	229	6	28	55	77	165

**HDD capacity (Gb) required per channel for set days**

Ch	RES.	Bit Rate	FPS	Bit Rate/kbs	Quality	Mb/h	1day	5days	10days	14days	30days
1	D1	VBR	6	128	1	101	2	12	24	34	72
					4	305	7	37	73	102	220
					6	364	9	44	87	122	262
2	D1	VBR	6	512	1	99	2	12	24	33	72
					4	300	7	36	72	101	216
					6	349	8	42	84	117	251
3	D1	VBR	6	1024	1	99	2	12	24	33	71
					4	302	7	36	73	102	218
					6	349	8	42	84	117	251
4	D1	VBR	6	2048	1	99	2	12	24	33	72
					4	301	7	36	72	101	217
					6	349	8	42	84	117	251

It should be noted that record times are only given as an estimate. Various factors including frame rate, bit rate setting, resolution and (in the case of VBR Bite Rate) quality, will all influence file size and resulting hard disk storage capacity. Altering any of these parameters will influence file size. In addition the complexity of the image will greatly influence files size, the more shades/colours included in the image the larger the files size will be.

By selecting 'Motion Detect' or 'Alarm' triggering of recordings note that the above times may be greatly extended.

## 11 Networking a Digital Video Recorder

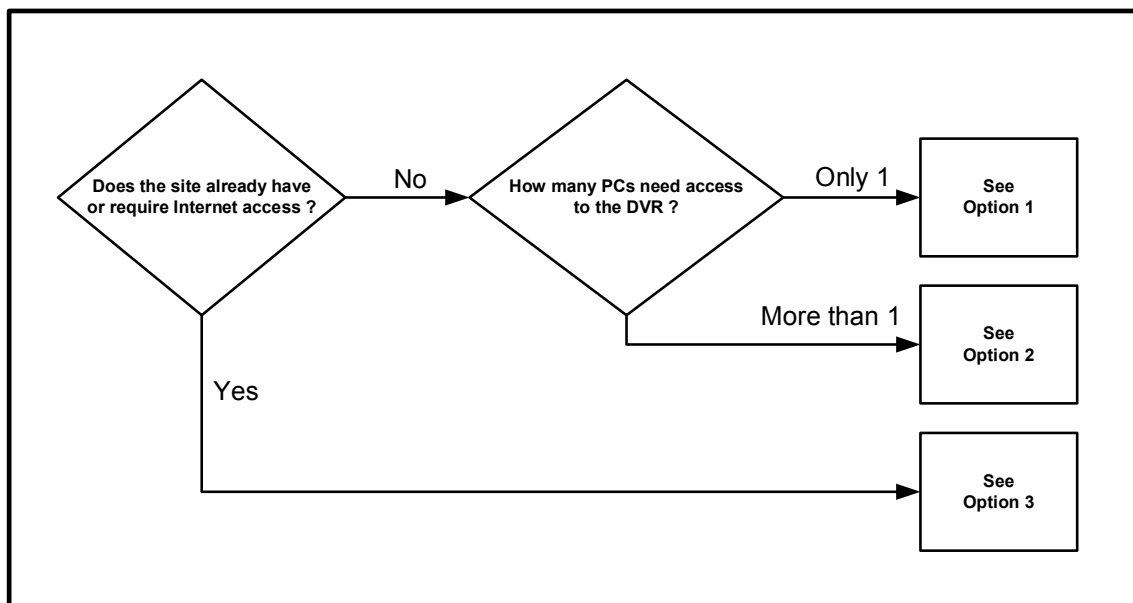

### 11.1 Basic Network Troubleshooting

You must be able to perform some basic tasks in order to connect your Digital Video Recorder to a PC and subsequently the Internet.

The following page describes some simple tasks but more help is available online at [www.systemq.com](http://www.systemq.com) so before you start please download the following tips from the website 'Online Support' section -

- Tip 117 Describing how to set a PCs IP Address
- TIP 36 Describing how to perform 'ping' test
- Tip 58 Describing how to configure a router for Internet access

The diagrams that follow suggest settings that if used will result in a successful connection.

Bear in mind that when it comes to Option 3 for Internet use, different router manufacturers may not use the exact settings given here so slight adjustments may be necessary.

### 11.1.1 How do I set my PC to ‘Obtain an IP address automatically’ ?

- Control Panel,
- Network Connections,
- Local Area Connection,
- Properties,
- Internet Protocol (TCP/IP),
- Properties,
- Select ‘Obtain IP Address Automatically’



### 11.1.2 How do I set my PC’s IP Address Manually ?

- Control Panel,
- Network Connections,
- Local Area Connection,
- Properties,
- Internet Protocol (TCP/IP),
- Properties,
- Select ‘Use following IP Address’
- Enter ... IP Address
- Subnet mask
- Default gateway

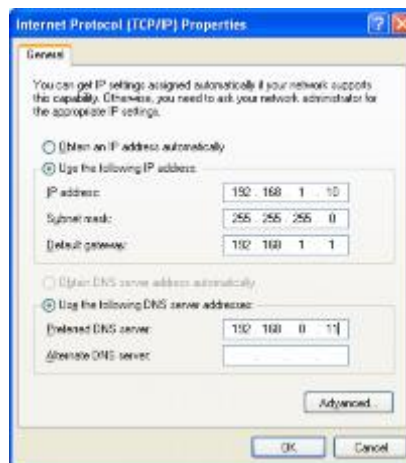

### 11.1.3 How do I find out my PC’s IP Address ?

- Start
- Run
- Cmd
- ipconfig

### 11.1.4 How do I use Ping to test a Connection to my DVR ?

- Start
- Run
- Cmd
- Ping <IP-Address> <Enter> eg: ping 192.168.1.108 <Enter>

### **11.1.5 How do I Configure a Router for Remote Access ?**

- Instructions on the System Q website cover the NET800 and Netgear Routers

### **11.1.6 How do I find the On-Line Support ?**

<http://www.systemq.com/cgi-bin/commerce.exe?display=user2>

Detailed descriptions are available there for all these questions plus more besides, including ...

- How to find a device's MAC address (Tip 3)
- How to implement Dynamic DNS (Tip 56)
- Setting Internet Explorer Security Settings to install an Active-X (Tip 94)
- How to control a PTZ from a DVR
- How to play back recordings from various DVRs
- Links for downloading client software packages

### 11.2.1 Option 1 : Connect a DVR Directly to a Single PC

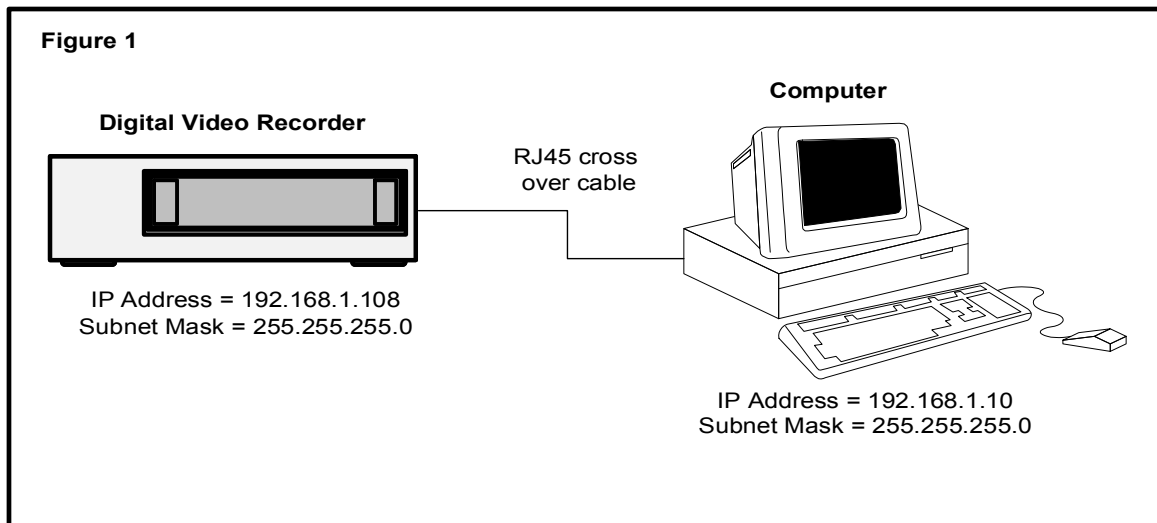

#### Tasks :

- Configure network settings in DVR manually
- Configure network settings in PC manually
- Connect DVR & PC together using an RJ45 cross over cable
- Install and configure the DVR client software
- Reboot both DVR & PC
- Test the PC's connection to the DVR using 'Ping'
- Connect using the client software



## 11.2.2 Option 2 : Connect a DVR to a PC via a Switch or Hub

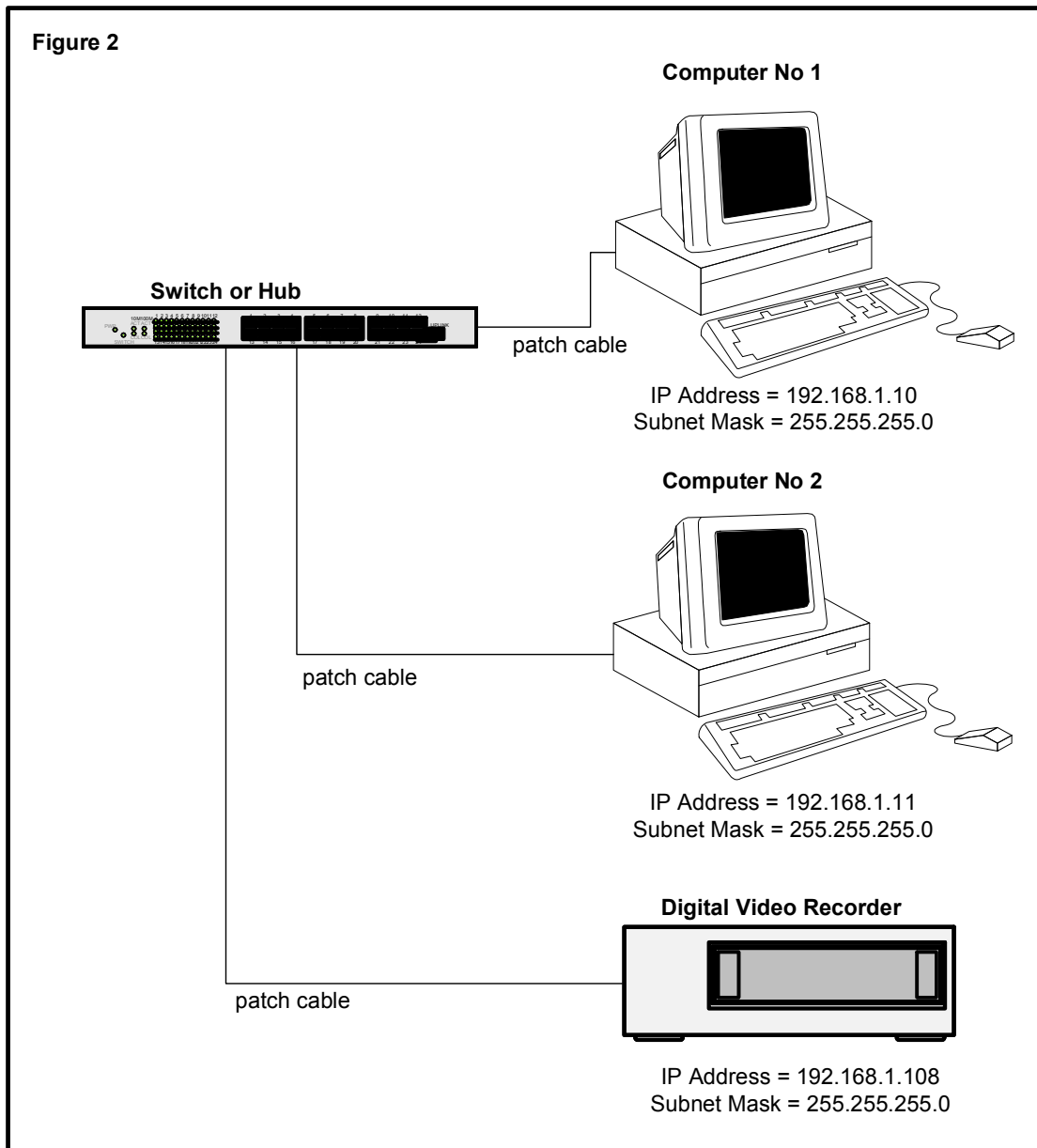

### Tasks :

- Configure network settings in DVR manually
- Configure network settings in PC manually
- Connect DVR & PC together using an RJ45 cross over cable
- Install and configure the DVR client software
- Reboot both DVR & PC
- Test the PCs connection to the DVR using 'Ping'
- Connect using the client software

### 11.2.3 Option 3 : Connecting for Internet Access

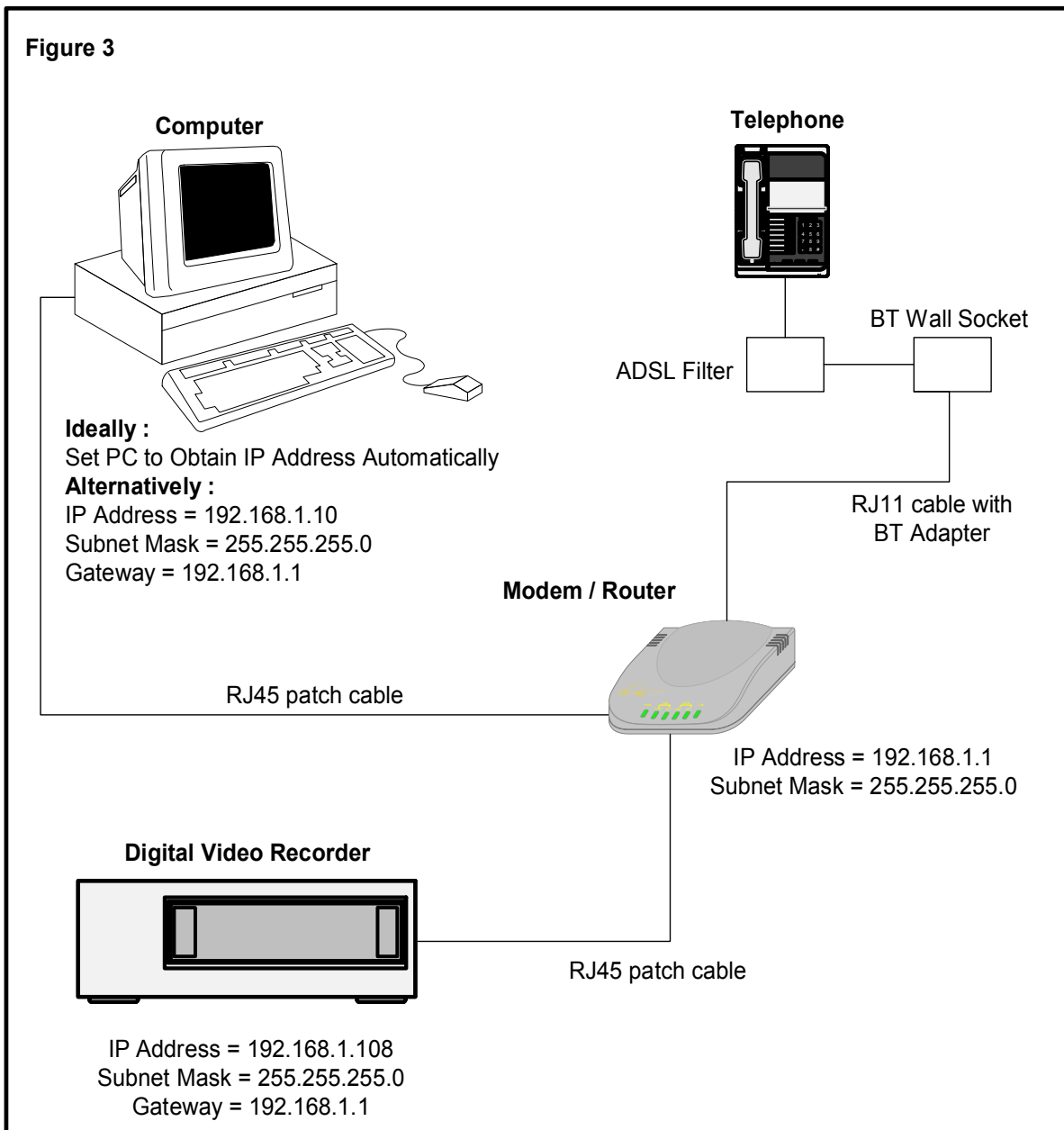

#### Important Notes :

If using a BT phone line you must use an ADSL modem router, if using a NTL or cable phone service you must use an appropriate cable router.

Be aware that when connected to the internet, the router has two IP addresses: internal and external. The internal address is seen by devices connecting to its Ethernet ports, the external address represents its connection to the local exchange via the telephone line.

**Tasks :**

- Find out what the external IP address is, this is assigned by the customer's Internet Service Provider
- Find out : is this a fixed IP address, ie: "Static, or does it change, ie: "Dynamic" ?
- Configure network settings in the DVR manually
- Configure network settings in the PC to "Obtain IP Address Automatically" if possible, if not, then configure manually
- Connect DVR & PC to the modem/router using patch cables
- Install and configure the DVR client software
- Reboot both DVR & PC
- Test the PCs connection to the DVR using 'Ping'
- Use the client software to connect to the DVR from the local PC
- Ensure the PC has outbound Internet access
- Configure the modem router for inbound access using either "Port Forwarding", or "DMZ"
- Ask a colleague offsite to test Internet access by connecting to the router's external IP address

## Appendix A HDD Capacity Calculation

Calculate total capacity needed by each DVR according to video recording (video recording type and video file storage time).

Step 1: According to Formula (1) to calculate storage capacity  $q_i$  that is the capacity of each channel needed for each hour, unit Mbyte.

$$q_i = d_i \div 8 \times 3600 \div 1024 \quad (1)$$

In the formula:  $d_i$  means the bit rate, unit Kbit/s

Step 2: After video time requirement is confirmed, according to Formula (2) to calculate the storage capacity  $m_i$ , which is storage of each channel needed unit Mbyte.

$$m_i = q_i \times h_i \times D_i \quad (2)$$

In the formula:

$h_i$  means the recording time for each day (hour)

$D_i$  means number of days for which the video shall be kept

Step 3: According to Formula (3) to calculate total capacity (accumulation)  $q_T$  that is needed for all channels in the DVR during **scheduled video recording**.

$$q_T = \sum_{i=1}^c m_i \quad (3)$$

In the formula:  $c$  means total number of channels in one DVR

Step 4: According to Formula (4) to calculate total capacity (accumulation)  $q_T$  that is needed for all channels in DVR during **alarm video recording (including motion detection)**.

$$q_T = \sum_{i=1}^c m_i \times a\% \quad (4)$$

In the formula :  $a\%$  means alarm occurrence rate

