

the excelPTZ range

Installation and Operation Manual PTZ505 series Iridium Silver Six-inch Standard Speed PTZ Dome

| | Optical Zoom | Total Zoom | Day/Night | IR Sensitive | Minimum Lux | TVL | Nite Plus |
|----------|---------------------|-------------------|------------------|---------------------|--------------------|------------|------------------|
| Option D | 18x | 216x | YES | NO | 1.0 | 480 | NO |
| Option F | 22x | 352x | YES | NO | 0.5 | 480 | NO |
| Option H | 22x | 352x | YES | YES | 0.5 | 480 | NO |
| Option J | 22x | 352x | YES | YES | 0.5 | 500 | NO |
| Option P | 30x | 300x | YES | YES | 0.001 | 480 | YES |
| Option T | 35x | 560x | YES | YES | 0.1 | 500 | NO |



Version 5

For updates to these instructions visit www.excelPTZ.com

Please read this operation manual carefully
before installing and using this unit !!!!



Please read the following;

1. Please read the operation manual carefully before installing and operating the product.
2. The actual dome requires a 24v AC power supply. The rated input voltage of the camera is 12V!!!! This gets its power from the dome and does not require a separate PSU. Do not connect 24V AC to the camera under any circumstances!!
3. During the course of transportation, storage and installation, the product should be handled with care avoiding vibration and any weight pressure, which may cause damage to the sophisticated optical and electronic equipment inside the machine.
4. Do not attempt to disassemble the camera. In order to prevent electric shock, do not remove screws or covers. There are no user-serviceable parts inside the camera.
5. Always use and stick to current electrical safety standards to install and use the dome. Use a correctly rated power supply. The RS-485 and video signal cables should be kept way from other high voltage equipment such as mains cables and especially fluorescent lights. Using an anti surge protection device is recommended to prevent damage to the domes from lightning and mains surges. Damage to domes by lightning or mains voltage surges is not covered under the domes warranty.
6. Do not operate in areas exceeding the stipulated limitations concerning temperature, humidity and power supply.
7. Do not aim the camera directly towards the sun or an extreme light source whether it is switched on or not. Do not let the camera focus on bright and stationery objects for a long time. Doing either of these may damage the camera.
8. Do not use strong detergents to clean the main body of the camera as these may damage the dome cover or paintwork. Wipe dirt with dry cloth. If needed a *mild* detergent can be used.
9. Operate the dome camera with great care to avoid shock or vibration. If operated incorrectly, the Dome could be damaged.
10. Ensure the dome is not dropped. Never mount the unit on a ceiling that cannot support its weight.
11. If necessary, use a commercial lens cleaning paper to clear the lens windows. Gently wipe the lens window until clean.
12. When transporting this Dome before installation always use the box and packaging supplied. This protects the unit and ensures the Dome is correctly supported.

KEY FUNCTIONS

The excelPTZ dome range –

The **PTZ505** range of domes are hi-tech CCTV products. They incorporate a high-clarity colour camera, panoramic speed-variable PAN/TILT, multifunctional decoder and on-board processor for logic handling. The domes are easy to connect, install, maintain and operate and have many features. The domes are compact and have a strong structure together with a modern and appealing appearance.

1. Integrated Multi-Protocol Decoder

- a. The integrated multi-protocol decoder can integrate a maximum of 16 kinds of communication protocols. The baud rate can be adjusted, and is compatible with many systems using easy setup facilities inside the dome.
- b. The dome uses RS485 serial control and can have an address range between 1-1023.

2. Integrated speed-variable PAN/TILT

- a. The dome can turn 360° horizontally and continuously with unlimited positions with an adjustable speed from 0.2 - 15rad/s and turning 0 - 90° vertically with a speed up to 12 rad/s.
- b. The dome can run at low speed with super low noise and with the benefit of no picture shake.
- c. The location precision is no less than $\pm 0.2^\circ$.

3. High Intelligent Settings

- a. As many as 64 preset positions can be preset with powerless memory.
- b. The camera can scan horizontally between two points and the scan speed can be modified. The positions on a linear scan are optional and the dome camera can scan a range larger or smaller than 180° between any two points with adjustable speed.
- c. The domes can be made to run the presets as a tour.
- d. The Integrated Multi-Protocol. Multiple communication protocols are integrated inside the dome camera with a selectable baud rate from 2400bps to 19200bps.
- e. The NitePlus camera module incorporates a slower shutter speed allowing the camera to see more at low light levels. This camera option is best suited to very slow moving scenes or stationary scenes.

4. Zoom Camera Functions

The functions of the Zoom camera are displayed on the monitor when the DISPLAY option on the camera is set to ON. Please note these menus depend upon what camera is installed inside the dome. Check appendix for the different alternatives.

Getting the dome up and running!



You **MUST** connect up the dome and your control equipment on a workbench or kitchen table before the actual site installation and **CHECK YOU KNOW HOW TO INSTALL IT CORRECTLY!!!!!!!!!!!!!!!!!!!!!!**.

By doing this you can set-up any DIP switches, adjust the camera, and learn about how it operates before taking it to site. This will save you hours of time on-site trying to work out why a particular item doesn't function as you expected it to. There is nothing worse than installing something and then having to take it down to see how to get it working!! Do the learning curve in the comfort of your own premises!!!!

Do you KNOW how to install PTZ equipment that is controlled by RS485 data signals?

If not please read the following introduction to PTZ >>>....

Overview- introduction to fitting PTZ equipment

Generally speaking, PTZ Domes requires four things;

- 1- They require a power supply and a cable to supply this power to the dome. Often, external domes are 24V A.C but some mini pan and tilt domes are 12V.
- 2- They require a cable to get the video signal back to the monitor or recording device.
- 3- They require a cable to transmit the "RS485 control signal" from the keypad or DVR to tell the dome to pan, tilt and zoom etc.
- 4- They require something to control them, either a keypad or a DVR.

The following diagram indicates the basic cable requirements for a PTZ system.

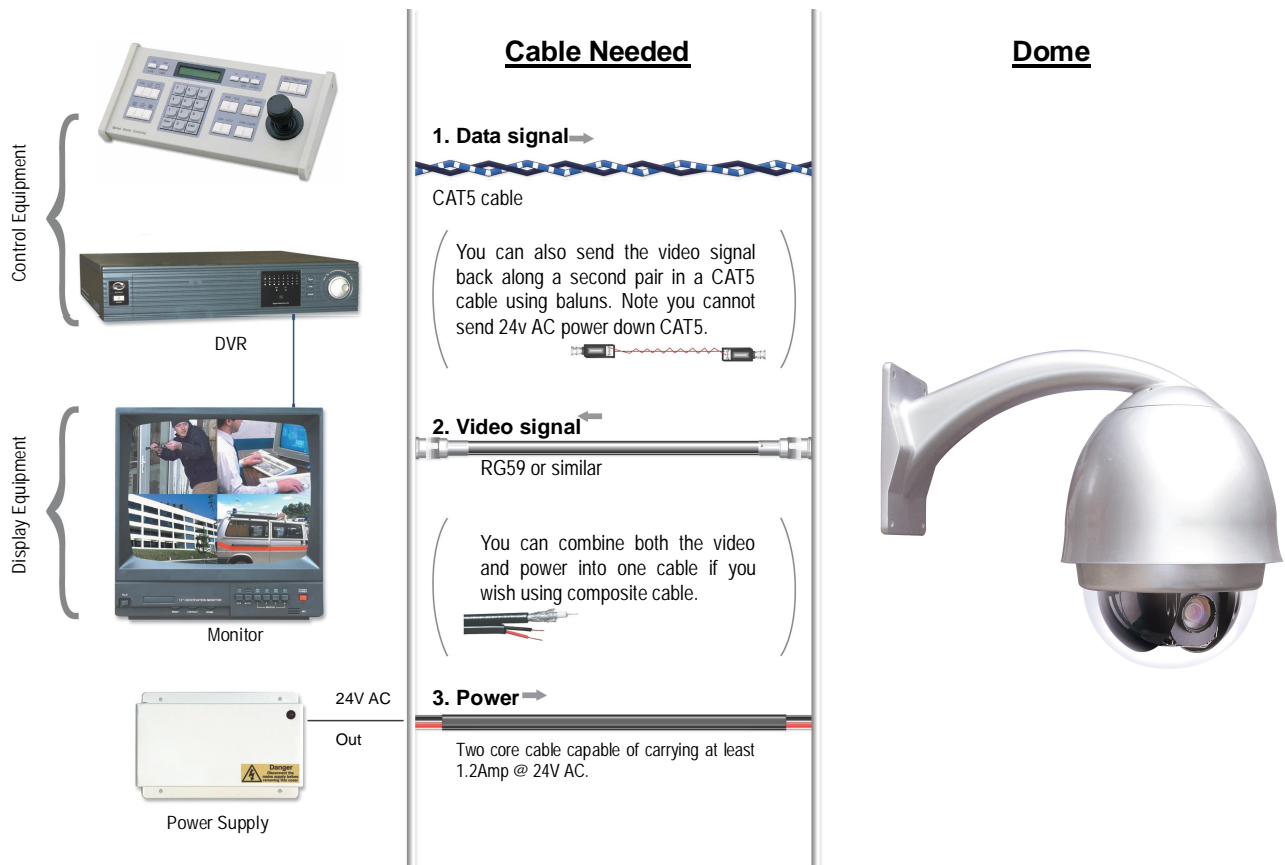

You can get “composite” and “combo” cables that will carry either both the power and the video signals or all three, power, video and data. You may choose to power the dome locally to it, so you may only need to get the video signal back and the RS485 control signals to it. If this is the case you may choose to use a pair of BALUNS. By using baluns you can send the video signal and control signal down the same CAT5 cable just using different cores for each signal. Note that you do not need to use baluns for the data signal.

The control signal (RS485) is nearly always sent along a “twisted-pair” type cable. The twists in the cable help prevent interference affecting the data signal by “shielding” it. Many installation companies use a CAT5 type or similar cable to run out to the domes to carry the data signal.

If you are considering using baluns please note - DVR’s tend to require very good video signals to function correctly and “passive baluns” can loose some signal strength over the 50 metre mark so try to restrict the use of passive baluns to below 50 metre cable runs when using them with DVRs. Above this distance perhaps consider an active balun. Active baluns require power, passive baluns do not.

You can mix and match how you wire up your PTZ installation and the following general diagram gives you a guideline about how to do it. Remember this is a GUIDE and is not an instruction what to fit!

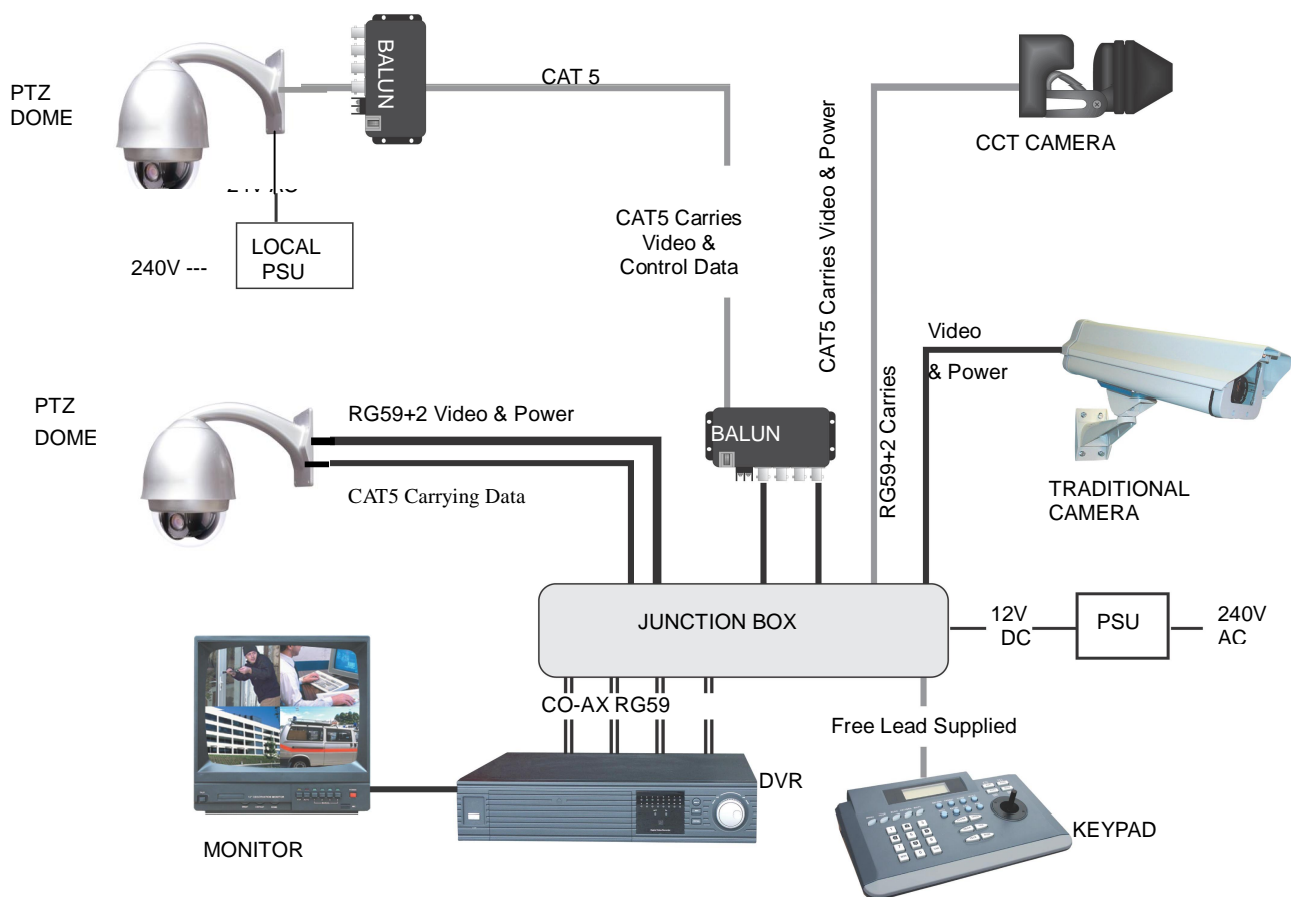

Many installation companies can get the power and video signal correct, but struggle with the control of the dome using the keypad or DVR using the RS485 data.

The key to successfully installing the data cabling to the dome is to get the basics right. Use a quality data cable such as CAT5 (never use just a standard untwisted cable such as alarm cable for the RS485 signal).

Also, you must follow the RS485 wiring convention; the following section explains this;

RS485 Wiring methods & Tips >>>>>

1. Characteristics of RS485

As specified by RS485 standards, RS485 is a half-duplex data transmission type with characteristic impedance of 120 Ω. The maximum load capacity is 32 units (domes, keyboards and DVRs).

2. Transmission distances of RS485 Signals using CAT5 or similar cables

Selecting a CAT5 or similar sized twisted pair data transmission cable, the maximum theoretical transmitting distances are as follows:

| Baud Rate | <u>Maximum</u> Transmitting Distance |
|--------------------|--------------------------------------|
| 2400 Bps (PELCO-D) | 1500m |
| 4800 bps | 1000m |
| 9600 bps | 600m |

PLEASE NOTE - Using inferior cables, or installing the dome in an environment with strong electromagnetic interference, or connecting a lot of PTZ domes to the same cable carrying the RS485 signal will reduce the maximum transmitting distance.

3. RS485 Connection methods

METHOD 1 – DAISY CHAIN CONNECTION.

The general RS485 standard recommends a “daisy chain” connection of equipment that is to be controlled. This means that the control cable is looped out of the one dome to the next dome and so on. The last dome in the line is then fitted with what is known as a “termination resistor”. This has a value of $120\ \Omega$.

The resistor is built in the PTZ domes and is activated by moving the appropriate “jumper” in the dome. The keyboard itself generally has a built-in $120\ \Omega$ resistor. These termination resistors help make the signal more stable and give the system better reliability so the domes function as expected. A common mistake installer’s make is not making sure the $120\ \Omega$ resistor is switched ON in the LAST dome. Also installers often select the resistor to ON in another dome in the chain, these errors will make control of the dome unpredictable.

A simplified Daisy chain is shown below;

This first diagram shows the cables looping in one dome and out of another;

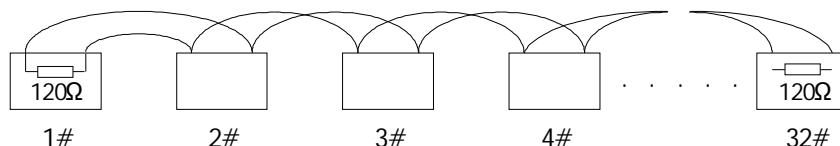

Standard Daisy-Chain connection for the RS485 PTZ control signal

(just the last dome only has the $120\ \Omega$ resistor set to on, the first device is the keyboard and has the $120\ \Omega$ built in as default)

This next diagram is a slight variation on the Daisy Chain arrangement. Again it’s one cable going out to all the domes but instead of the cable going into each dome then back out to the next one, a junction box is used to “Spur-Off” to each dome. Whilst this can be done **THE SPUR LENGTH (D) must be NO MORE THAN 10 meters!!!!!!!!!!!!!!** The overall cable length between the Controller and the last dome is limited to around 300 meters in such an arrangement.

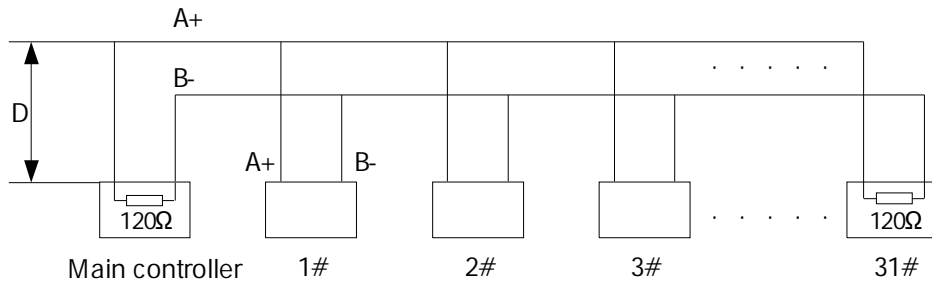

Daisy-Chain connection WITH SHORT SPURS for the RS485 PTZ control signal

(one main radial with very short spurs to each dome off it, keeping the spurs to less than 10 meters)

TIP - The connection of a 120 Ω termination resistor: The termination resistor is ready fitted on the domes pcb, all you have to do set it is move the jumper from Pins 2 &3 to pins 1 & 2.

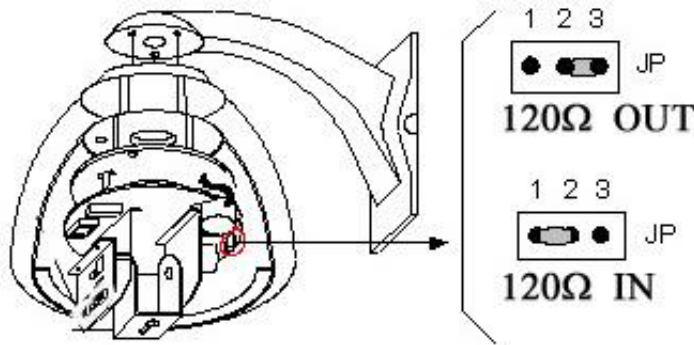

A- This is the factory default connection, the 120 Ω is not connected. Most of the domes should be like this.

B- For the **last** dome in the daisy-chain the 120 Ω resistor is put in circuit by moving the jumper across Pin1 & Pin2 as shown.

STAR method of connection.

In some circumstances you may need to adopt a star configuration for practical purposes. For instance, all the domes may be so scattered on a large site that running out separate spurs to each dome in a “STAR” array is the only practical solution.

So how do you do this in practice?

The termination resistors must be connected to the two domes that are farthest away from each other, such as domes 3 and 5 in the following “Star diagram”. Note that all the other domes do not have the 120ohm resistor connected. The resistors are already fitted to the domes PCB but by default are not in circuit. To put them in circuit you must move the small “jumper” as previously indicated.

As the star configuration is not in conformity with the requirements of RS485 standards, problems such as signal reflections may arise, especially when there are long cable connections. The results are that control signals are decreased and the dome may not respond to, or just responds intermittently to the controller.

If your STAR circuit is not too extensive with each spur in the region of 20-50 meters you can expect quite good reliable performance using this technique. If you experience any problems though, there is a RS485 distribution box available CODE PT750 to help overcome any problems.

The Star circuit for wiring PTZ's.
 The two furthest domes need the 120ohm resistors enabling, by moving the "Jumper"
In this example it's domes 3 & 5.

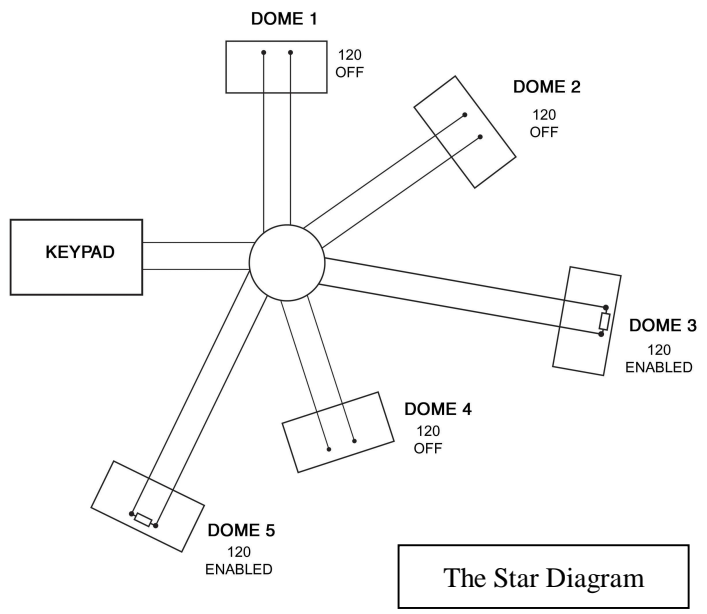

Overcoming RS485 data loss using an RS485 distributor

In the real world not everything always works exactly as it's expected to!

RS485 data signals that control the domes' movements are tiny signals that can get corrupted for many reasons. Poor cable quality, not using a PAIR of cores from a CAT5 but using one core from TWO separate pairs, running the CAT5 cable near mains equipment such as florescent lighting all will have a detrimental effect on the signal. These are things that you can correct with good installation practices.

Where you wish to run several separate CAT5 cables out to send the RS485 data signal out to the domes you are in effect correcting the STAR method of RS485 data distribution. As previously mentioned the problem with the Star method is that it is not actually designed for RS485 but generally works okay if you follow the previous notes on getting the 120ohm resistor setting right, as per the previous notes.

One way that takes the guesswork out of installing the Star method is to utilise an RS485 distributor. This has the advantage that the RS485 signal is correctly distributed to the domes so that they behave as expected. You can create up to 4 spurs to the domes and put up to 4 domes on each spur. Just like the Daisy chain method the end dome on each spur needs to have the 120ohm resistor enabled.

Although the RS485 distributor is a small additional expense, it takes some of the guess work out of the installation design and gives a more flexible approach to cabling which itself can save time and money on the installation. Not forgetting you get more predictable results!

The RS485 distributor (PTZ750) amplifies the RS485 control signal and distributes it evenly to 4

separate spurs, each spur can have up to 4 domes. This means that you could theoretically have up to 4 individual spurs of over 1000mtrs each to control up to 16 PTZ domes in total.

Ideally you would put just one dome on each spur from the PTZ750 but up to 4 domes is generally acceptable. The following diagram shows a typical use of the PTZ750 RS485 distributor.

In the following example and diagram, domes 1,4,5 and 7 are at the end of each spur and therefore require the 120ohm resistor enabling by moving the jumper setting within the domes. Domes 2,3 and 6 are all “midway” in each spur and do not need the 120ohm resistor and can be left as default. The PTZ750 itself has four 120ohm resistors built in as shown and you do not have to do anything with the PTZ750 as the resistors are permanently connected within it.

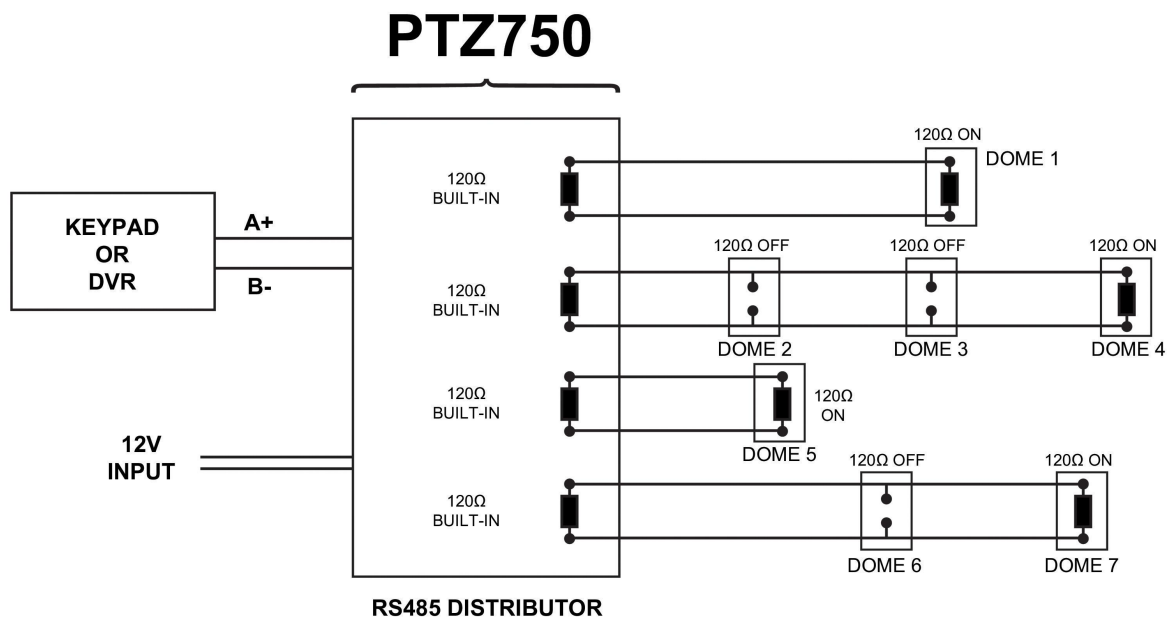

(Diagram showing how to use an RS485 distributor to improve PTZ control reliability)

Please note if you have the PTZ750 located within 5mtrs of the keypad or DVR you can connect up to 3 of them in parallel.

Setting up the Dome Camera

1. Connection of the System

There are many ways to wire up a PTZ system.

If you have read the introduction at the beginning of these instructions you should have got a good idea what your options are.

Below is a general schematic diagram showing you some of these options.

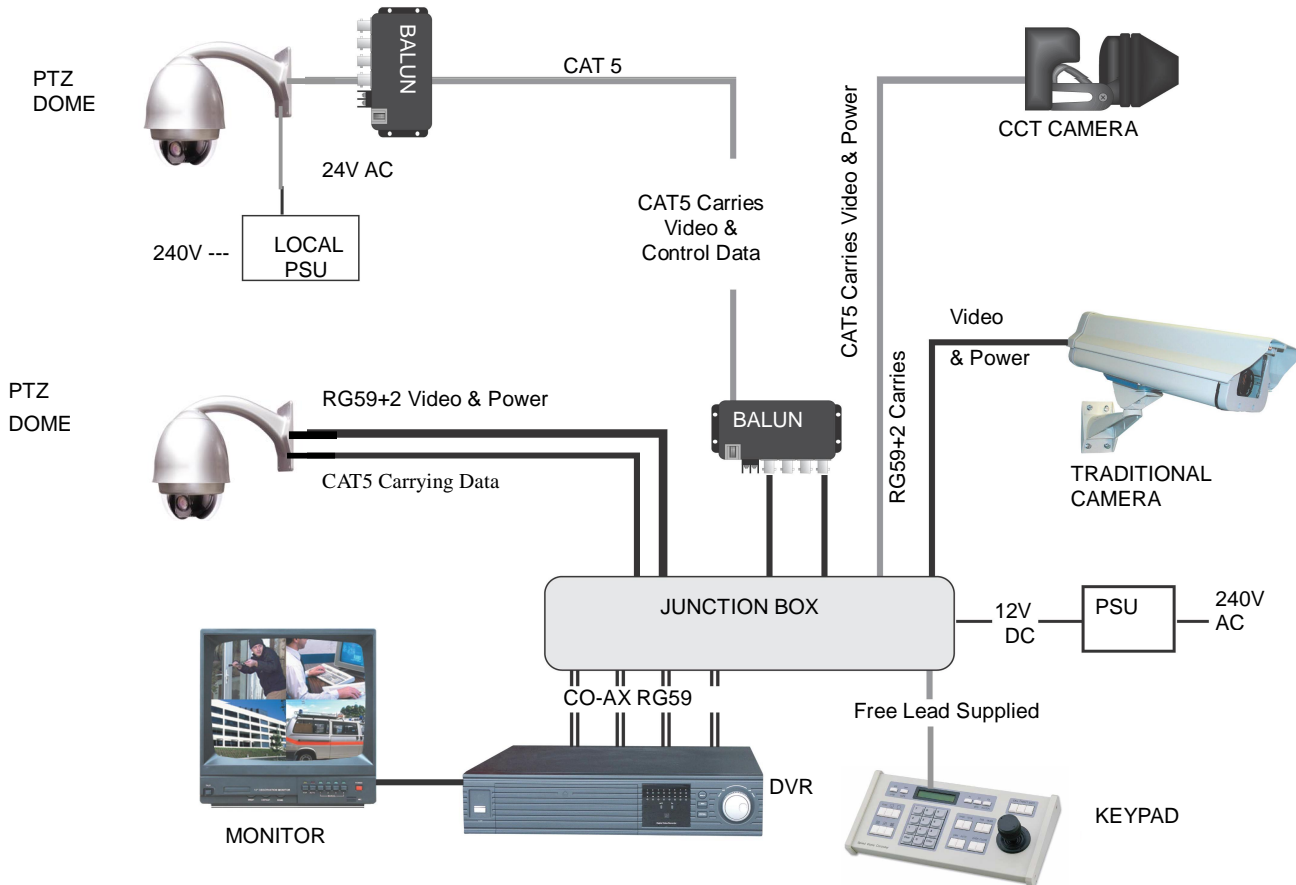

Figure 1.

Powering the domes-

All the domes will need power. For this dome it is a 24V A.C power supply. The power supply must be capable of delivering at least 2.5A per dome.

You can either power each dome with its own PSU locally to it or have the PSU's remotely situated perhaps near the keyboard or DVR. The domes require a current of about 1.7A when the heater is on and you must take this in to consideration when working out maximum cable runs. Always allow about 30% headroom on the psu so that it is not running flat out continuously.

Please note - The domes heater doesn't come on until it senses the temperature drops below 0 degrees Celsius. At this point the dome will need up to 1.7A @ 24V A.C to operate. Please make sure that you have a sufficient power supply and cable installed to cope with this. Obviously the dome may work

okay in the summer but when winter kicks in and the dome's current draw jumps from 400ma to 1.7A and an inadequate power supply or a cable with too much voltage drop may stop the dome from working properly. When winter comes don't be suddenly caught off guard when your customer rings you to say the dome has suddenly packed in because it's gone cold!!

A popular way to power the domes is using our COMPOSITE VIDEO cable (or shotgun as its also known) as this cable can carry the power to the dome and the video signal back to the monitor or DVR.

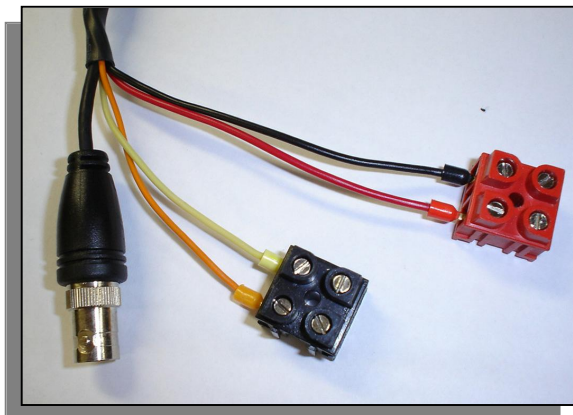

The power connection

The RED & BLACK cable coming out of the dome connected to the RED terminal block are for power. Connect a suitable 24V A.C power supply to this pair of cores.

The BNC connector is the "VIDEO-OUT" from the camera and goes to the monitor or "VIDEO-IN" of a DVR camera input.

The Orange and Yellow pair of cores that go in to the BLACK terminal block are the data cables. These are the cores that carry the RS485 control signal to the dome from either the keypad or the DVR. The next section of the instructions gives more detail on how to connect the RS485 data. Please also read the RS485 WIRING METHODS & TIPS section towards the beginning of these instructions.

RS485 connection - Connecting the Keypad or DVR to the Dome.



The dome is controlled by an RS485 data signal that is given by either a KEYPAD or a suitable DVR. This data signal tells the dome to pan, tilt, zoom etc. Its important that you read the early section of these instructions to understand the fundamental principle of RS485 cabling techniques so that you get it right.

RS485 has two cores, A and B or sometimes known as RS485 + (A) and RS485 - (B) if you get these two the wrong way around then you will not be able to control the dome. Sometimes installers get the connections right on one dome but not on the other and find only one dome works. They then swap the wires around at the keyboard only to find out one dome has now burst in to life and the other one now failed!! But they don't put 2 + 2 together and realize their mistake that they have wired one dome different to the other. Take great care getting these the right way around and make sure you wire each dome IDENTICALLY so that if you have to swap the A & B lines over at the keyboard you know all domes are wired the same!!

In the PTZ505 series adopts the following RS485 convention;

ORANGE = RS485 + or A
YELLOW = RS485 - or B

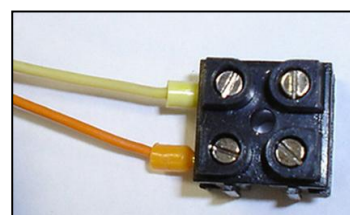

You should initially be wiring the dome to the keyboard or DVR on your workshop bench or at least your kitchen table to prove you know how to get everything to work. Once you have done this, it is just a job of extending the cables and physically installing the domes on site. You must obviously take note of the RS485 wiring techniques mentioned at the beginning of these instructions and get the 120ohm resistors correct in the “End of line” domes. Generally speaking you will always be extending the RS485 signal from either the keypad or the dome using a CAT5 or similar cable.

The PTZ730 and PTZ700 are two keypads that can be used with the PTZ505 series. On the rear of the keypads you will see the RS485 connections. Ensure they are connected correctly i.e the RS485 + A line and the RS485 – B line. Note that both these keypads need to be set to the same protocol as the PTZ dome. Refer to the relevant keypad instruction manuals on the keypad dipswitch settings.

PTZ730 keypad

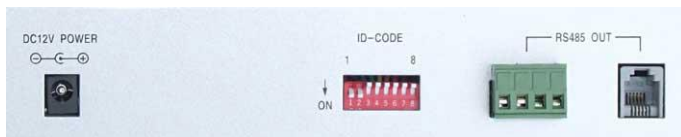

Rear of PTZ730



RS485 connections

PTZ700 keypad



Rear of PTZ700



RS485 connections

If you use cores from two different pairs in the CAT5 cable you will not get the benefit of the shielding effect of the cable twists and the dome will function erratically. You must always use a core from a PAIR, not two cores from two different pairs!!

Connecting the video out of the dome.

The dome has a short BNC lead attached to it, this is the lead that carries the video signal from the built-in camera. You need to extend this lead to the “VIDEO-IN” of the DVR or monitor. Use a good quality RG59 coax cable or similar to do this.

TIP – If you can’t get a picture at the remote end you could always take your test monitor to your PTZ dome and check the picture quality on its own short BNC lead.

If you’re testing the equipment on a workbench you now have a one dome system.

For setting up the keyboard and testing the dome please read sections on default Dome settings and using the keyboard.

You can use a keyboard or a suitable DVR to control the dome. A suitable DVR would be one with PTZ functionality built in to it and preferably PELCO-D protocol. If your DVR has a list of protocols it’s always best to try PELCO-D first or the JEC protocol, as these are very widely available. In the DVR with either PELCO-D or JEC set you must make sure you set up the “baud-rate” to 2400. JEC protocol is very similar to PELCO-D but has a wider tolerance.

A typical site installation would look like the following diagram on the next page.

It shows the dome connected to the keypad plus how the dome could also be connected to a DVR instead of the keypad or at the same time. DVR’s that have the capabilities of PTZ control will have a terminal or connection on them somewhere, where the dome’s RS485- A and RS485- B line can connect to. Please refer to the individual DVR instructions of how to do this.

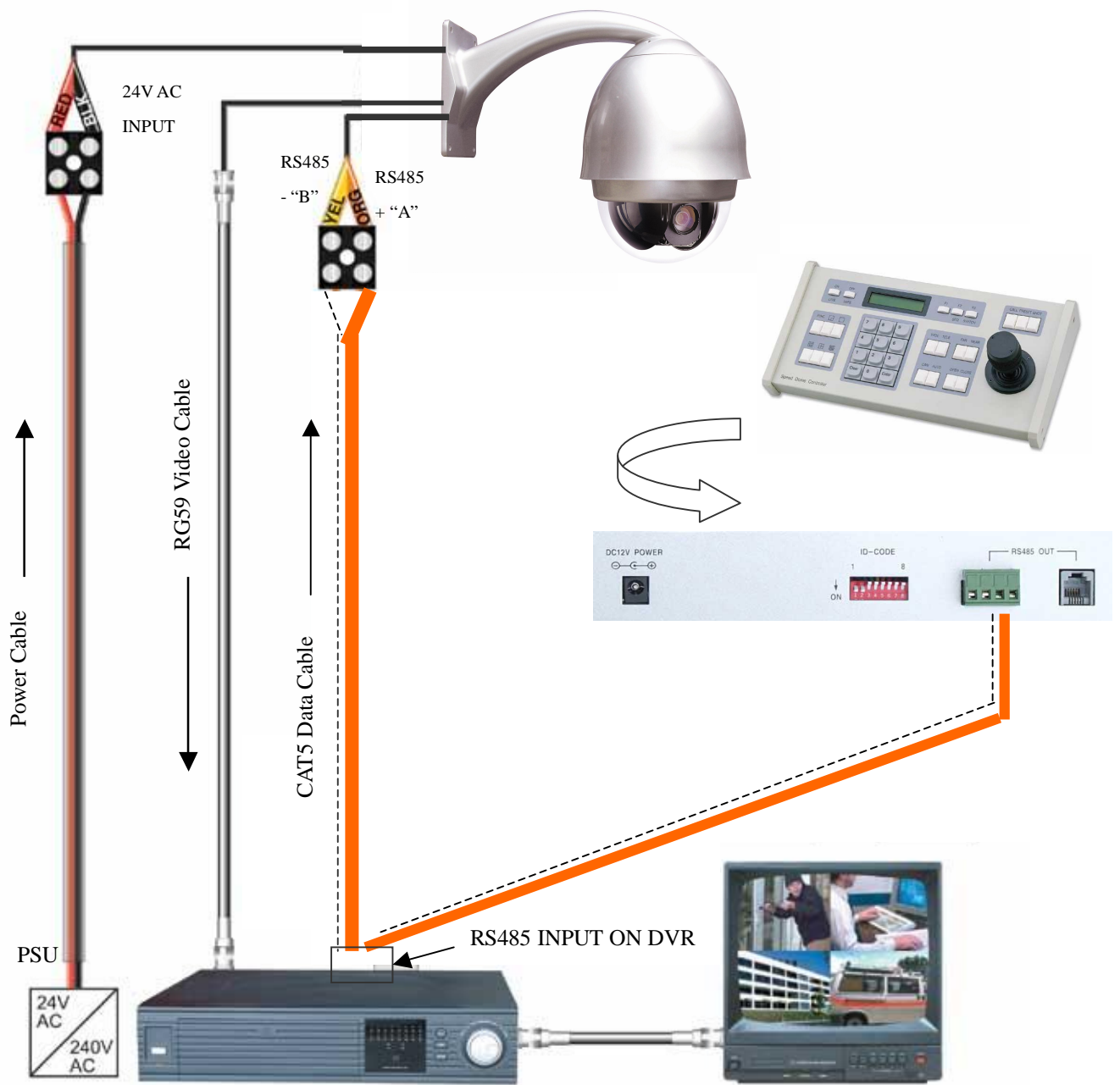

If you're using more than one dome on a site

Each dome has a unique "address" so that if you are using more than one on a site the keyboard "talks" to the right dome when you want it to PTZ. If you only have the one dome on the site then the default "address" of "1" is okay and you have no reason to change the dome from this.

With multiple dome sites you need to set up each dome address separately.

The following diagram shows the switch options.

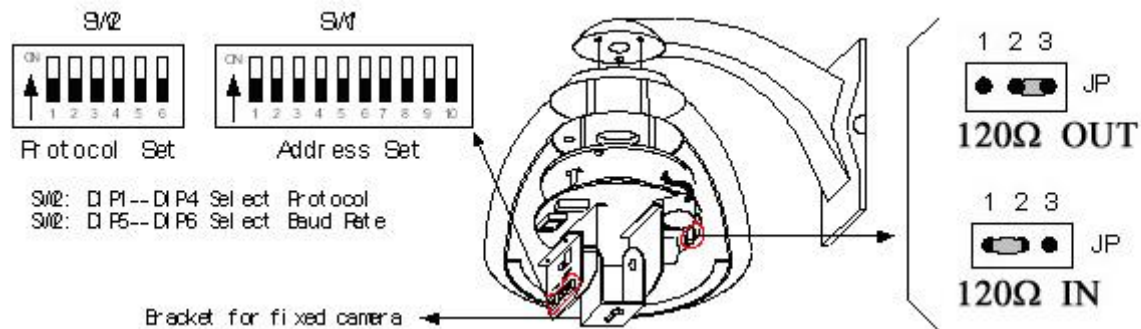

SW2 sets up the protocol. This switch is dealt with later in these instructions.

For most System Q equipment they should always be set to PELCO-D 2400 baud rate. The Jumper on the far right either enables or disables the 120ohm resistor.

Setting up a unique ADDRESS in a dome –

SW1 is used to set address of the dome camera from 1 – 1023.

To set the dome address at 1 put switch 1 up.

To set the dome at address 2 put switch 2 up

To set the dome at address 3 put switches 1 & 2 up.

..and so on..

The following table indicates how this is done.

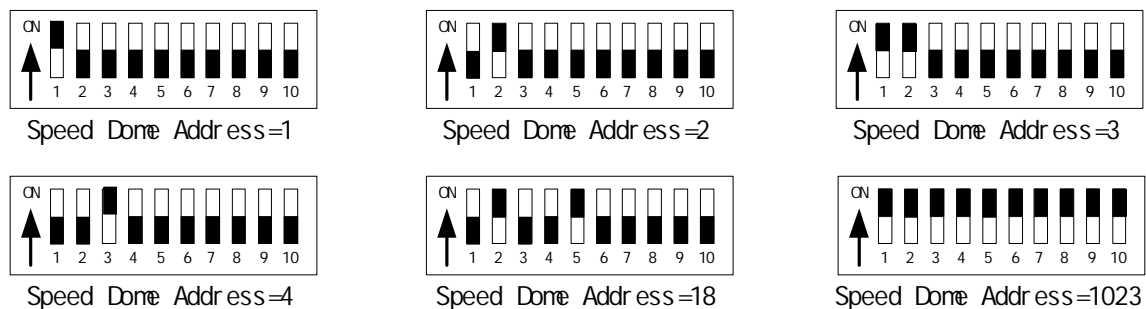

| Dome Address | ID-CODE Status | | | | | | | | | |
|--------------|----------------|-------|-------|-------|-------|-------|-------|-------|-------|--------|
| | DIP-1 | DIP-2 | DIP-3 | DIP-4 | DIP-5 | DIP-6 | DIP-7 | DIP-8 | DIP-9 | DIP-10 |
| 1 | ON | OFF | OFF | OFF | OFF | OFF | OFF | OFF | OFF | OFF |
| 2 | OFF | ON | OFF | OFF | OFF | OFF | OFF | OFF | OFF | OFF |
| 3 | ON | ON | OFF | OFF | OFF | OFF | OFF | OFF | OFF | OFF |
| 4 | OFF | OFF | ON | OFF | OFF | OFF | OFF | OFF | OFF | OFF |
| 5 | ON | OFF | ON | OFF | OFF | OFF | OFF | OFF | OFF | OFF |
| 6 | OFF | ON | ON | OFF | OFF | OFF | OFF | OFF | OFF | OFF |
| 7 | ON | ON | ON | OFF | OFF | OFF | OFF | OFF | OFF | OFF |
| 8 | OFF | OFF | OFF | ON | OFF | OFF | OFF | OFF | OFF | OFF |
| 9 | ON | OFF | OFF | ON | OFF | OFF | OFF | OFF | OFF | OFF |
| 10 | OFF | ON | OFF | ON | OFF | OFF | OFF | OFF | OFF | OFF |
| 11 | ON | ON | OFF | ON | OFF | OFF | OFF | OFF | OFF | OFF |
| 12 | OFF | OFF | ON | ON | OFF | OFF | OFF | OFF | OFF | OFF |
| 13 | ON | OFF | ON | ON | OFF | OFF | OFF | OFF | OFF | OFF |
| 14 | OFF | ON | ON | ON | OFF | OFF | OFF | OFF | OFF | OFF |
| 15 | ON | ON | ON | ON | OFF | OFF | OFF | OFF | OFF | OFF |
| 16 | OFF | OFF | OFF | OFF | ON | OFF | OFF | OFF | OFF | OFF |
| 17 | ON | OFF | OFF | OFF | ON | OFF | OFF | OFF | OFF | OFF |
| 18 | OFF | ON | OFF | OFF | ON | OFF | OFF | OFF | OFF | OFF |
| ... | ... | ... | ... | ... | ... | ... | ... | ... | ... | ... |
| 1023 | ON | ON | ON | ON | ON | ON | ON | ON | ON | ON |

Table 1

2. Setup of the Protocol and the Default Baud Rate.

As shown in Table 2, SW2 is used to set the protocol of communication and the baud rate used by the dome camera. DIP-4 to DIP-1 of SW2 is used to select protocols and a maximum of 16 different protocols can be selected. The following table shows states of coding switches of protocols selected by the dome camera in which ● means the protocol has been integrated while ○ means the protocol is underdevelopment.

Pelco-D 2400 is used for most System Q equipment.



| Type of Protocols | Selection of Protocols | | | | Normal Baud Rate | |
|-------------------|------------------------|-------|-------|-------|------------------|-------|
| | DIP-1 | DIP-2 | DIP-3 | DIP-4 | DIP-5 | DIP-6 |
| SAMSUNG | ON | OFF | OFF | OFF | ON | ON |
| BO1 | ON | OFF | OFF | OFF | OFF | ON |
| NEON | ON | OFF | OFF | OFF | OFF | ON |
| Santachi | OFF | ON | OFF | OFF | OFF | ON |
| PELCO-D | ON | ON | OFF | OFF | OFF | OFF |
| PELCO-P/4800 | OFF | OFF | ON | OFF | ON | OFF |
| PELCO-P/9600 | | | | | OFF | ON |
| PANASONIC | ON | OFF | ON | OFF | OFF | ON |
| Longcomity | OFF | ON | ON | OFF | OFF | ON |
| HUNDA600 | ON | ON | ON | OFF | OFF | ON |
| LILIN | OFF | OFF | OFF | ON | OFF | ON |
| VICON | ON | OFF | OFF | ON | ON | OFF |
| MOLYNX | OFF | ON | OFF | ON | OFF | ON |
| KALATEL | ON | ON | OFF | ON | ON | OFF |
| VCL | OFF | OFF | ON | ON | OFF | ON |
| Reserved | ON | OFF | ON | ON | OFF | ON |
| ALEC | OFF | ON | ON | ON | OFF | ON |
| Utralk | ON | ON | ON | ON | OFF | ON |

Table 2

Some protocols and the states of the coding switches of normal baud rates of these protocols are shown as follows:



Setup of the Baud Rate of Communication.

As shown in Figure 2, SW2 is used to set the protocol of communication and the baud rate used by the dome camera. DIP-6 and DIP-5 of SW2 are used to select the baud rate of communication and 4 different baud rates can be selected in maximum. If the controller adopts a non-standard baud rate, you can adjust it to be identical with that of the controller, as per the following table.

| Baud Rate of Communication | DIP-1 | DIP-2 | DIP-3 | DIP-4 | Setup of Baud Rate | |
|----------------------------|-------|-------|-------|-------|--------------------|-------|
| | | | | | DIP-5 | DIP-6 |
| 2400bps | | | | | OFF | OFF |
| 4800bps | | | | | ON | OFF |
| 9600bps | | | | | OFF | ON |
| 19200bps | | | | | ON | ON |

Using the PTZ730 keypad with the excelPTZ series



PTZ730 keypad

NOTE 1: For more detailed instructions in setting up the keypad or using one of our other keypads, please refer to the instruction manual supplied with the product.

NOTE 2: The PTZ730 keypad requires you to press the function key first followed by the value e.g <CAM> 01 <Enter> whereas some keypads e.g PTZ700 require the value first, then the function e.g 01 <CAM> <Enter>

When you first take the keyboard out of the box you will need to set it up for the domes that you are using.

The dome you have purchased has the default settings of; PELCO-D 2400-BAUD rate Address 1

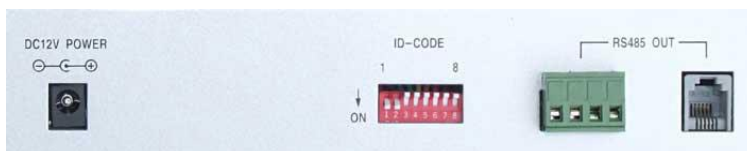

Rear of PTZ730 keypad

First read through the keypad instruction manual supplied. Set the protocol and baud rate in the keypad using the dipswitches on the rear of the unit. Note that all PTZ domes controlled by this keypad must have identical protocol and baud rate settings. The manual supplied with the keypad will show you what these settings should be.

Next connect the RS485 connections from the dome/s ensuring that the A and B lines are connected correctly.

Finally connect the power supply. Both the PTZ730 and PTZ700 keypads require a 12V DC PSU (500mA minimum). It is recommended to use a POW800 for this purpose. Now press the keypad ON button.

Select a PTZ camera by pressing CAM button followed by camera address and Enter*. The LCD display will indicate the camera channel selected. CAM 01 indicates that the keyboard is ready to talk to camera with address 1, if you have another dome set at camera address 2, press CAM button followed by 02 and Enter. This would change the display screen to CAM 02.

If you have multiple domes you will need to change the address of each dome so they are different but PLEASE LEAVE THE DOMES ON PELCO-D 2400 BAUD RATE.

- see NOTE 2 above.

PRESETS and other functions.

The dome has up to 64 presets that once programmed will stay in the domes non-volatile memory so they will be retained even after a power cut.

What is a preset? A preset is a particular area or object that the dome was looking at and has been stored into its memory so when the preset is “called-up” the dome will rotate and aim at the area again without the operator using the joystick to do this. Even the zoom at the time is stored into the preset. This means that you could for example store a PRESET of a car-park entrance. When the operator calls up this preset the camera automatically zooms in on this area. By storing more than one preset you can add even more functionality to the dome. By having two presets, you can then get the dome to “SCAN” between the two locations. You can even vary the speed of this scan.

Having 3 or more presets you can get the dome to go on a TOUR of the presets. When you run the tour the dome goes to one preset, then waits a short period then on to the next preset and so on. The dome continues to cycle around this tour until you cancel it. The length of time the camera stays at one location is about 3 seconds. You can put several presets that are at the same location to lengthen this time. In the dome some preset numbers are reserved for special functions, these are listed as follows;

| PRESET No. | Special function | What you press at the PTZ730 keyboard | |
|------------|--|--|---|
| | | Press CALL xx Enter (xx = preset No) | Press PRESET xx Enter (xx = preset No) |
| 51 | Auto scan | Starts the scan at a low speed setting | TOUR FUNCTION Runs a TOUR of all the presets (see 64 for PELCO-D) |
| 52 | | Starts the scan at a middle speed setting | The location the scan starts from. |
| 53 | | Starts the scan at a high speed setting | The location the scan ends at |
| 54 | Camera power – This switches off the camera module only and not the dome. Useful to reboot the camera if required without switching off the power. | Power on | Power off |
| 55 | Back light | On | Off |
| 56 | ICR short | On | Off |
| 57 | OSD - ON/OFF The built in camera module has its own menu that can alter the way it works in the dark etc. You can access the menu through the preset 57 | On <i>Navigation</i> is done with the TELE & WIDE buttons. <i>Selection</i> is made with the NEAR & FAR buttons. | Off To turn off the OSD use the TELE & WIDE buttons to navigate through the options to the exit menu and use the NEAR & FAR buttons to exit. |
| 58 | Digital Zoom (if fitted) | On | Off |
| 59 | FOCUS | Auto | Manual |
| 60 | IRIS | Auto | Manual |
| 61 | White Balance Mode | Auto | Manual |
| 62 | | Indoor | Outdoor |
| 63 | | ATW | One Push WB |
| 64 | Auto scan (Pelco-D/Pelco-P) | Autoscan at low speed | Run a Tour |

If you wish to use the auto scan function YOU MUST USE preset 52 as the starting point of the scan and preset 53 as the ending point of the scan. Note that when using the Pelco-D, Pelco-P or Santachi protocols, an alternative preset number 64 may be more suitable in some keypads.

PRESETS -How to set up a preset

Aim the dome where you want it to look, zoom in or out to get the correct scene and let the camera auto focus. Now press the following keys **PRESET xx Enter** (where xx is the preset number you wish to store). For example **PRESET 01 Enter** would store **PRESET 1** and the camera would always go to this location when 1 is “CALLED”.

To test if the preset is stored correctly use the joystick to move the camera to point in a new location. Now press **CALL 01 Enter** (where xx is the preset you wish the camera to go to). In this example if you press **CALL 01 Enter** the dome should go straight to the PRESET 01 location.

TIP -You may wish to write down a list of presets that you have stored next to the keyboard for the operator.

CALLING a preset

This may be as follows;

PRESET 01 = MAIN GATE (a long zoom shot)

PRESET 02 = ENTRANCE DOOR

PRESET 03 = FIRE ESCAPE

PRESET 04 = EMERGENCY EXIT

PRESET 05 = CAR PARK (zoomed-out wide angle)

PRESET 06 = CAR PARK (zoomed-in narrow angle)

When the operator wishes to quickly zoom in on the MAIN GATE all he has to do is press **CALL 01 Enter**. To go to the EMERGENCY EXIT he would press **CALL 04 Enter** and so on.

To call up any previously stored preset camera location, simply press **CALL xx Enter**, where xx is the preset number.

AUTO SCAN- How to set it up

Auto-scan scans between the two presets 52 & 53 as indicated in the previous example.

STEP 1-Aim the camera where you wish to start scanning from, now press **PRESET 52 Enter**

STEP 2-Aim the camera where you wish to end scanning from, now press **PRESET 53 Enter**

The dome now knows the two outer limits of its scan. You can run the scan at 3 different speeds to activate any one of these using the following methods;

To start a SLOW auto scan press **CALL 51 Enter** or **CALL 64 Enter**

To start a MEDIUM SPEED auto scan press **CALL 52 Enter**

To start a FAST-SPEED auto scan press **CALL 53 Enter**

TIP - To stop the scan just move the joystick slightly.

Tours – How to set them up and use them

A tour is simply a collection of preset camera locations that are run in sequence with the dome stopping at each location for a brief period then moving on to the next preset.

For example, you could use a tour so that an outside dome camera points at a gate, then at a side doorway then zooms out to get an overall shot of a car park finally zooming in on a delivery bay before repeating the whole cycle again. Tours can be useful for both outside and internal PTZ's. For a shop they could be used to cover key areas like clothes rails, tills and changing rooms in a sequence.

To set up a tour you need to set up the individual stop points where the camera will pause at. These are called *presets*.

An example mini-tour;

STEP 1-Aim the camera where you wish to start the tour from now press **PRESET 01 Enter**

STEP 2-Aim the camera at the next location, now press **PRESET 04 Enter**

STEP 3-Aim the camera at the next location, now press **PRESET 07 Enter**

STEP 4-Aim the camera where you wish to end the tour from now press **PRESET 10 Enter**

STEP 5- To run the tour press **PRESET 51 Enter or PRESET 64 Enter**

TOP TIP – In the above example deliberate spaces are left between the presets. *By doing this it's easy to add extra stop off points for the dome! Also you can enter the same location if you wish for multiple presets and it will make the camera pause at this location longer.*

Every time you wish to run the tour press **PRESET 51 Enter or PRESET 64 Enter**. To stop the tour just move the joystick slightly. Note that Preset 64 is used for Pelco-D, Pelco-P and Santachi protocols only.

Deleting a preset

You may wish to delete a preset.

To do this press **PRESET xx OFF**

For example to delete preset 1; press **PRESET 01 OFF**

Obviously if you wish to overwrite a preset with a new location simply aim the camera at the new location and store the preset as normal, this will simply overwrite the old preset.

On Screen Graphics (OSD) – changing the modules settings

The zoom module within the dome has a built in camera. You can adjust some of its parameters by entering its On-Screen-Graphics display. (OSD)

To bring up the camera menu press **CALL 57 Enter**. The camera's OSD is then displayed on the screen. You can navigate between the various options using the TELE & WIDE buttons located on the keypad. To select an option use the NEAR & FAR buttons also on the keypad. To exit this menu you use the TELE & WIDE buttons to navigate to exit, then select this using the NEAR & FAR buttons.

The actual camera functions are either located at the end of these instructions or in a separate set of instructions supplied with this dome.

Controlling one camera then another.

If you look at the image of the LCD display you can see the 01 indicates that the keyboard is ready to talk to camera with address 1. In the dome the address 1 is set as default in the factory. You need to alter the DIP-switches within the domes to address 2, 3 etc if you have multiple domes on the same site, refer to the previous instructions how to set the DIP Switches. If you have another dome set at camera address 2, press CAM followed by 2. This would change the screen to 02. And so on.

The Installation of the System

1. Type of Installation

a) Wall Installation

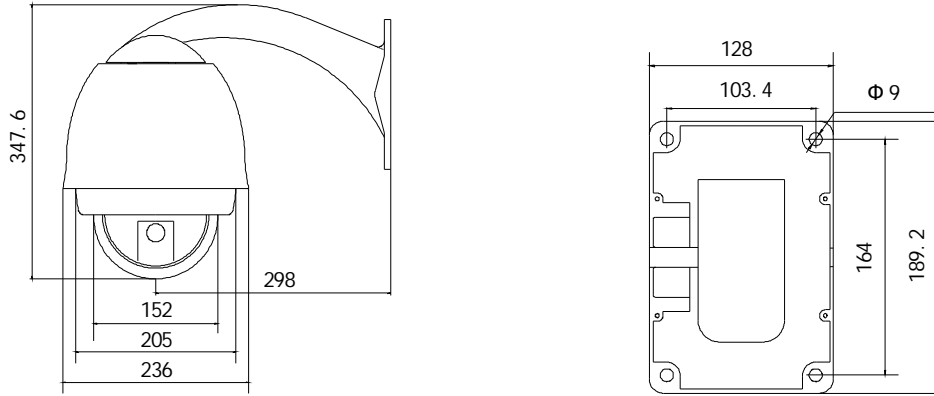

Figure 1

b) In-Ceiling Installation

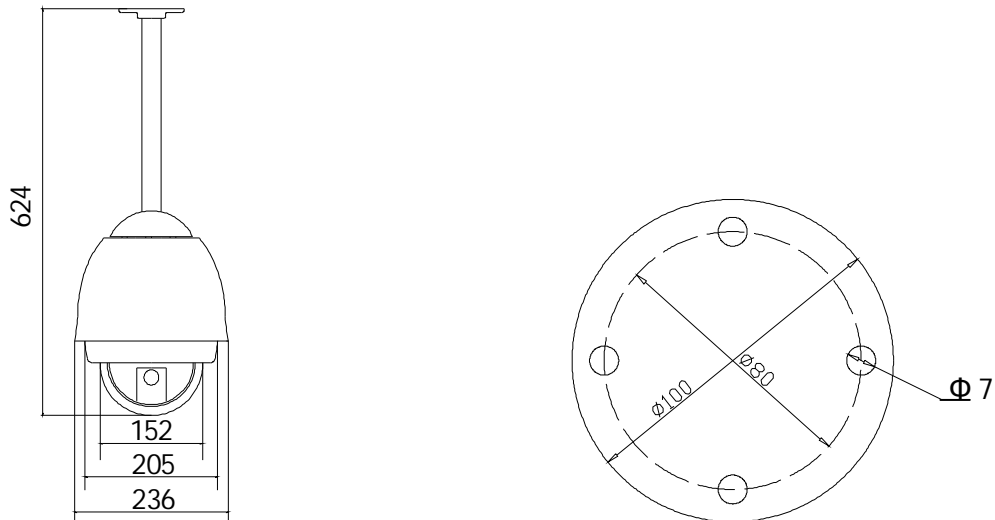

Figure 2

2. Installation Steps (taking wall installation as example)

a) Preparation before installation --- dome setting

- 1) Turning the dome cover anticlockwise (Figure 3) and take out the inner black cover (Figure 4).
- 2) Set the dome protocol, baud rate and address of the dome. This is explained in further detail earlier in this manual.

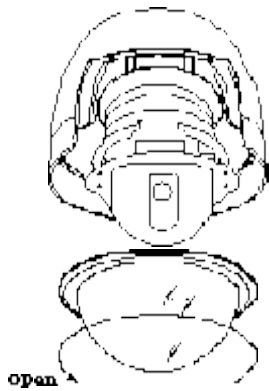

Figure 3

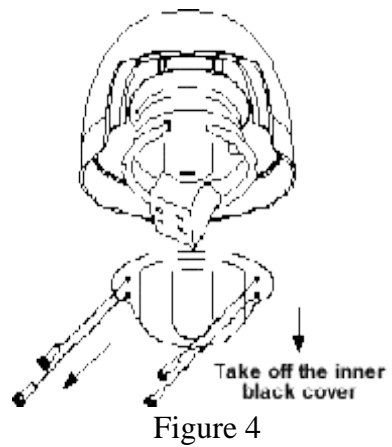

Figure 4

- 3) Install the inner black cover (Figure 5).
- 4) Install the dome cover (Figure 6).

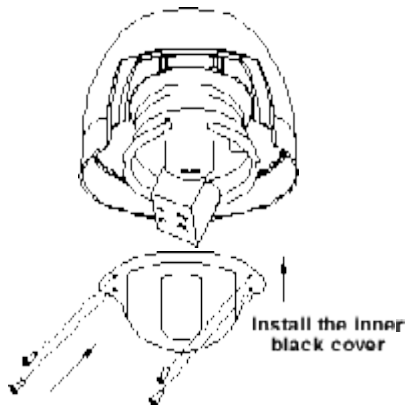

Figure 5

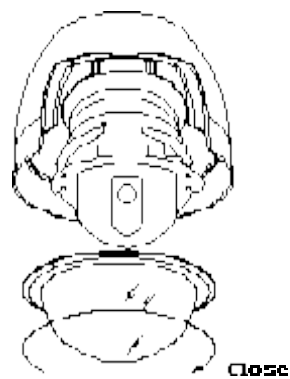

Figure 6

b) Installation of the bracket

Make four M8 holes on the wall, and put the four M8 bolts into the holes as Figure 7.

Make a hole at the center of the four holes to connect the cable of the bracket as Figure 7.

- i. Put the bracket on the wall and tighten the four M8 screws as Figure 8.

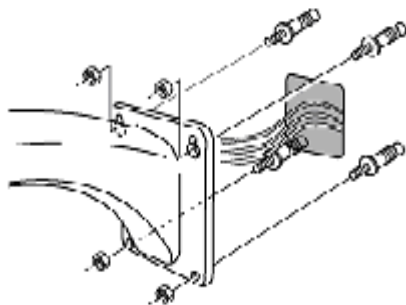

Figure 7

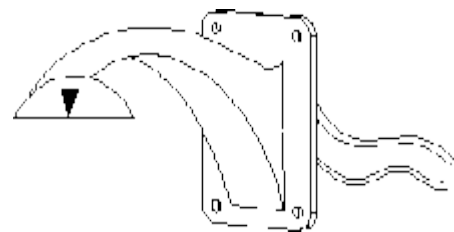

Figure 8

ii. Aim the “▼” of the bracket (A) to the “▲” of the dome (B) as Figure 9.

iii. Push the dome (B) up and turning it anticlockwise as Figure 10.

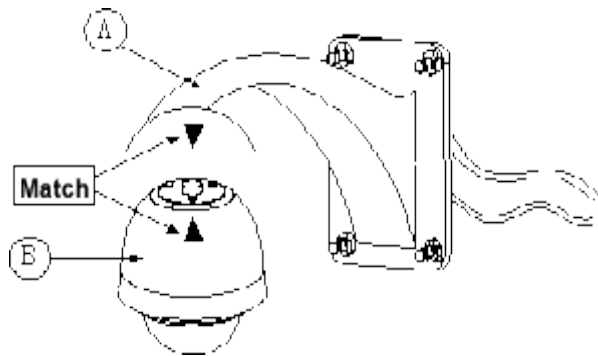

Figure 9

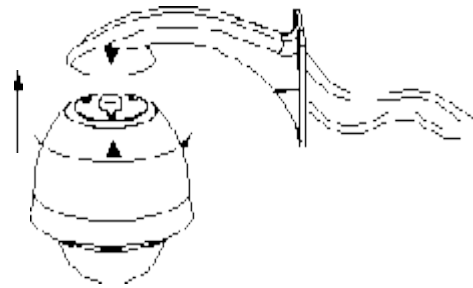

Figure 10

iv. Lock the housing as Figure 11.

v. Tighten M4×18 screws as Figure 12.

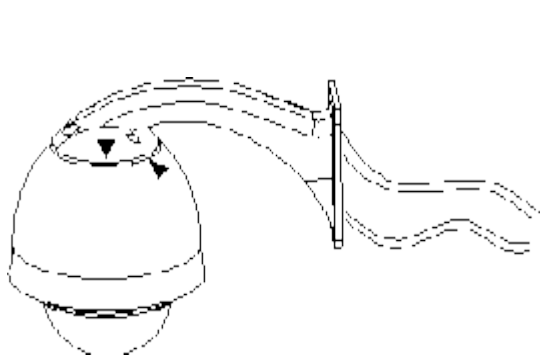

Figure 11

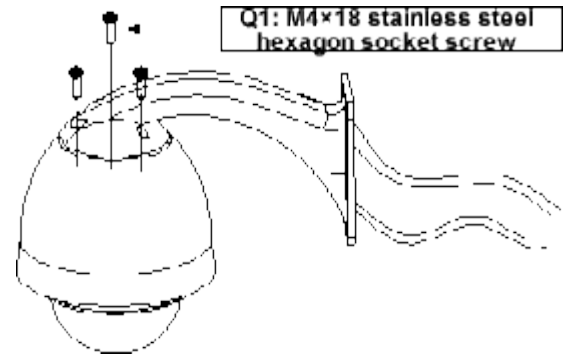

Figure 12

vi. Connect the control cable as Figure 15.

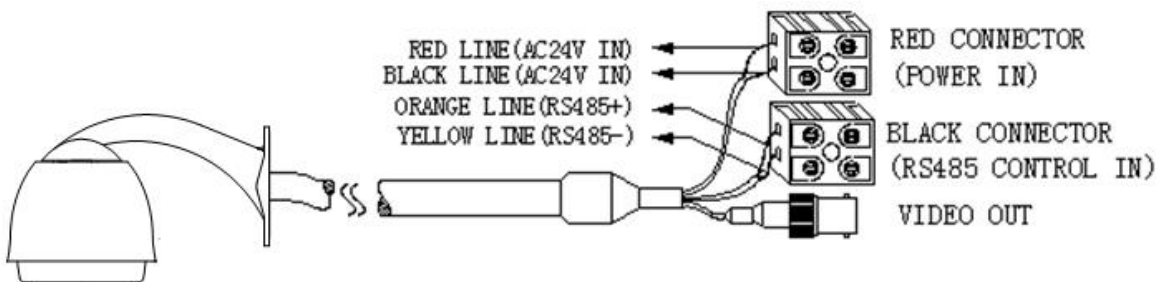

Figure 13

Appendix A: General Information

The Cleaning of Clear Dome Cover

To obtain constant clear images, the user should clean the down cover periodically.

- | Be very careful when cleaning. Hold the down cover ring only to avoid touching the acrylic dome cover. The acid from fingerprints will corrode the coating and any scratches on the dome cover may cause distorted or poor images.
- | Use a soft dry cloth or a similar to clean the inner and outer surfaces.
- | For more stubborn contamination, use a neutral detergent. Any cleanser for high-grade furniture is applicable.

Technical data table

| | |
|-------------------|---|
| Power Supply | 24VAC 50/60Hz 1.7A |
| Power Consumption | 35W (including fan and heater) |
| Synchronisation | Internal |
| Preset Positions | 64 |
| Tours/Patrols | Maximum 6 |
| Pan scanning | 360° programmable |
| Pan Speed | Maximum 15° per second |
| Pan Range | 360° continuous |
| Tilt Range | 0 ~ 90° |
| Tilt Speed | Maximum 12° per second |
| Communication | RS485 |
| Baud Rate | 2400 / 4800 / 9600 / 19200 BPS |
| Relative Humidity | 10 ~ 75% |
| Work Temperature | Indoor: 0°C ~ +40°C Outdoor: -35°C ~ +55°C |

Built-In ZOOM CAMERA MODULE

The zoom module within the dome has a built in camera. You can adjust some of its parameters by entering its On-Screen-Graphics display. (OSD)

To bring up the camera menu press **CALL 57 Enter**. The camera's OSD is then displayed on the screen. You can navigate between the various options using the TELE & WIDE buttons located on the keypad. To select an option use the NEAR & FAR buttons also on the keypad. To exit this menu you use the TELE & WIDE buttons to navigate to exit, then select this using the NEAR & FAR buttons.

The actual camera functions are either located at the end of these instructions or in a separate set of instructions supplied with this dome.