



BAL604
4Ch Active Balun Rx

BAL654
4Ch Active Balun Tx

Transmit Video Down CAT5 Up To 2000m!

The BAL604 4ch active balun receiver and the BAL654 active balun transmitter allow transmission of real-time monochrome or colour video over Unshielded Twisted Pair (UTP) CAT5. All types of composite signal are supported. A balun is required at both ends of the cable run and the CAT5 can be connected via an RJ45 connector or via the appropriate connection on the terminal block.

The BAL604 receiver must go at the DVR end of the cable run. For cable runs of up to 1000m the BAL604 can be used with a passive balun at the camera end of the installation. For cable runs of up to 2000m the BAL604 needs to be paired with an active balun transmitter such as the BAL654.

Co-axial cables are classed as an "unbalanced" mode of transmission and CAT5 twisted pair is known as a balanced mode. In this balanced mode, the two cores carrying the video signal are balanced to a particular reference point and the cable twists enable a uniform rejection of interference, effectively cancelling it out. To produce an unbalanced signal **BALUNs** are used, standing for **BAL**anced to **UN**balanced.

Baluns come in two distinct groups. **Passive** baluns require no power to operate and work up to distances of about 500mtrs although if you are using baluns to send video signals back to multiplexers, quads and DVRs it is recommended not to use passive baluns over 200mtrs. **Active** baluns require power for their "active" circuitry and can send video signals up to 2km down low-cost CAT5 cable. Most baluns do not allow you to send power down the CAT5 cable so **you will still need to power the camera** locally or run another separate cable for power.

What's In A Balun?

Baluns contain small signal transformers that are specially tuned to match the cables impedance and convert the unbalanced signal to a balanced one and vice versa. Passive baluns just have the transformers and very little else in them. Active baluns have extra electronic circuits used to amplify the signals helping prevent losses and also filtering out unwanted noise.

For more information on pairing passive and active baluns see online tip 317 ▶▶▶



Features

- Transmit Up To 2000m
- 2.1mm 12V DC Socket (150mA)
- BNC Video Connections
- Twisted Pair & RJ45 Connections
- Brightness & Sharpness Control
- Range Control

Specification

FUNCTION	SPECIFICATION
Bandwidth	8 MHz
Video Connections	BNC Sockets
CAT5 Connections	Terminal Strips Or RJ45 Sockets
Max Distance	2000m
Power	12V DC
Current	150mA
Power Connection	2.1mm DC Socket
Dimensions	203 x 119 x 48mm

Options Available

PART CODE	DESCRIPTION
BAL604	4Ch Active Balun Receiver
BAL654	4Ch Active Balun Transmitter

Other Products To Consider



Mini 1ch Passive Baluns (Pair)
BAL102



2.1mm 500mA 12V DC Plug-in PSU
POW150

All specifications are approximate. System Q Ltd reserves the right to change any product specifications or features without notice. Whilst every effort is made to ensure that these instructions are complete and accurate, System Q Ltd cannot be held responsible in any way for any losses, no matter how they arise, from errors or omissions in these instructions, or the performance or non-performance of the equipment that these instructions refer to.



This symbol on the products and/or accompanying documents means that used electronic equipment must not be mixed with general household waste. For treatment, recovery and recycling please return this unit to your trade supplier or local designated collection point as defined by your local council.

WEE/CG0783SS

The Advantage Of Using CAT5 Cable

CAT5 cable allows a tremendously flexible way to install and distribute CCTV signals around buildings and between locations. If for example you have two buildings over 1000mtrs apart you could use one CAT5 cable to run 4 CCTV images from one building to another by using active baluns. This provides savings on both labour and cable costs. Often you can find a spare CAT5 cable that is not being used but was put in originally as a spare data cable. CAT5 cable is also easy to handle and quite low cost. New commercial buildings are often "flooded" with CAT5 cabling, allowing tremendous scope to alter where and how CCTV cameras are used without necessarily having to install new and additional cables. Computer installation engineers use what are called "patch panels" and can also be used with great success for CCTV installations. In this structured cabling system you have to work out where CCTV equipment may be needed and install the appropriate CAT5 outlets nearby. It is also wise to provide some local source (or potential source) of power. By bringing all the CAT5s to one area and installing what is called a "patch panel" you can then re-distribute the signals however you please.

Using The BAL604 & 654 Video Balun

The balun requires a pair of cores in the CAT5 cable to send each video signal down. The BAL604 receive must always be at the DVR end of the installation. If the BAL654 transmitter is use it must always be at the camera end of the installation and will only work with an active balun receiver.

As The BAL604 and 654 are active baluns they will either need to be powered locally or by using a separate cable.

One balun convert the unbalanced signal to balanced for communication across the CAT5 balanced twisted pair and the second balun converts the balanced signal back to an unbalanced signal. Therefore two baluns are always required. As a continuous signal is required baluns cannot send the video through "hubs" or computer "switches" as they work in purely analogue method rather than the digital "packet" method of hubs or switches. This means that you cannot use baluns to send video pictures through existing computer networks that use switches or hubs.

- Step 1** Run in your CAT5 cable. This needs to be run between your camera and the rest of your CCTV equipment. One CAT5 cable with 4 pairs can theoretically carry 4 video signals, one per each pair of cores. It is good practice to run in more CAT5 cable than you actually need as this gives flexibility to add extra cameras, audio feeds etc.
- Step 2** Identify the various pairs within the CAT5 cable. Four pair CAT5 cable has 4 easy to identify pairs.
- Step 3** Connect the SAME pair of cores to both the baluns using the terminal connections or RJ45. Always adopt the same standard using the SOLID colour core as "-" and the striped core as "+" when connecting to the balun terminals. It does not matter which pair of cores you choose to use but they must be a pair and you must get the polarity of the cores correct at the baluns (See diagram on [page 5](#)).
- Step 4** Use a BNC-BNC lead to connect the BAL654 active transmitter balun to each camera. Similarly use another BNC-BNC lead to connect the BAL604 active receiver to the monitor or DVR etc.

IMPORTANT You may get a good picture when connecting directly into a monitor but a poor or bright picture when connecting into a DVR or a quad. This is because monitors are very "forgiving" with the level and quality of the video signal supplied to it. Quads, Multiplexers and DVRs are far less forgiving and require a near perfect video signal to give good results.

For more information on pairing passive and active baluns see online tip 317 ▶▶▶



Features

- Transmit Up To 2000m
- 2.1mm 12V DC Socket (150mA)
- BNC Video Connections
- Twisted Pair & RJ45 Connections
- Brightness & Sharpness Control
- Range Control

Specification

FUNCTION	SPECIFICATION
Bandwidth	8 MHz
Video Connections	BNC Sockets
CAT5 Connections	Terminal Strips Or RJ45 Sockets
Max Distance	2000m
Power	12V DC
Current	150mA
Power Connection	2.1mm DC Socket
Dimensions	203 x 119 x 48mm

Options Available

PART CODE	DESCRIPTION
BAL604	4Ch Active Balun Receiver
BAL654	4Ch Active Balun Transmitter

Other Products To Consider



Mini 1ch Passive Baluns (Pair)
BAL102



2.1mm 500mA 12V DC Plug-in PSU
POW150

All specifications are approximate. System Q Ltd reserves the right to change any product specifications or features without notice. Whilst every effort is made to ensure that these instructions are complete and accurate, System Q Ltd cannot be held responsible in any way for any losses, no matter how they arise, from errors or omissions in these instructions, or the performance or non-performance of the equipment that these instructions refer to.



WEE/CG078355

This symbol on the products and/or accompanying documents means that used electronic equipment must not be mixed with general household waste. For treatment, recovery and recycling please return this unit to your trade supplier or local designated collection point as defined by your local council.

BAL604 Receiver - Connections

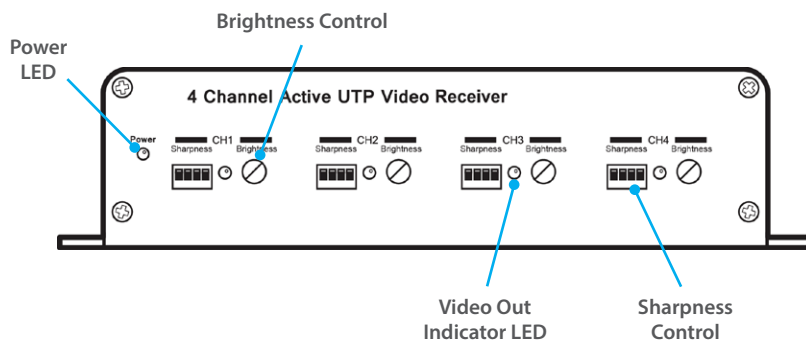
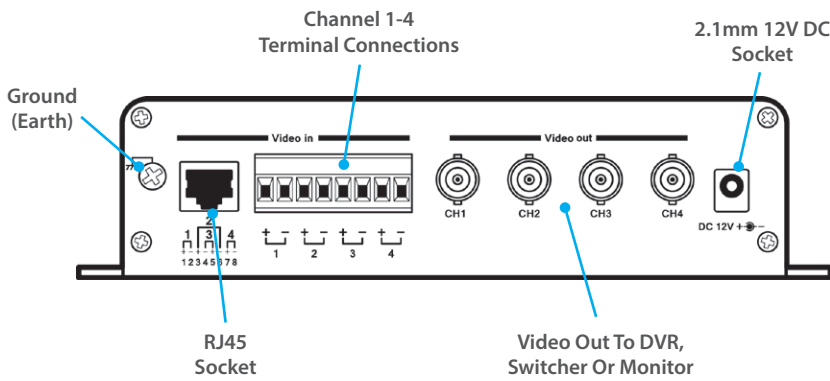

BAL604 Receiver - Controls

The brightness for each channels is simply controlled by the knobs on the side of the unit. Twisting the knob left and right will turn the brightness up and down for the respected channel.

The sharpness of each channel is controlled by a series of 4 dip switches. The dip-switches work on a binary system where the length of the cable run dictates the level the sharpness is set to. Very short cable runs would have the sharpness set to 0 where as maximum 2000m cable runs would need the dip-switches setting to 15.

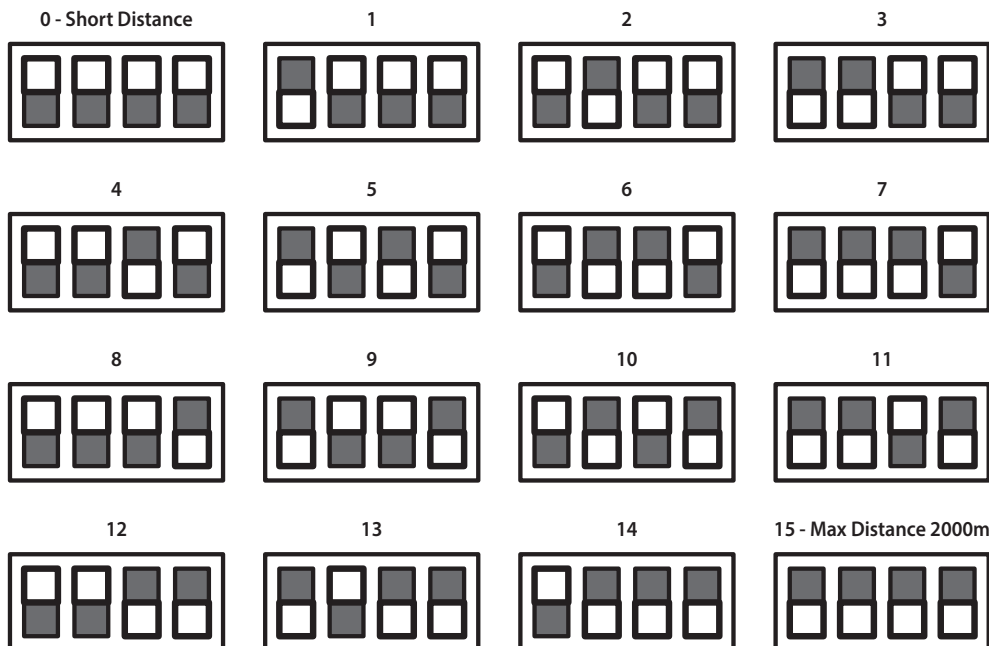

Features

- Transmit Up To 2000m
- 2.1mm 12V DC Socket (150mA)
- BNC Video Connections
- Twisted Pair & RJ45 Connections
- Brightness & Sharpness Control
- Range Control

Specification

FUNCTION	SPECIFICATION
Bandwidth	8 MHz
Video Connections	BNC Sockets
CAT5 Connections	Terminal Strips Or RJ45 Sockets
Max Distance	2000m
Power	12V DC
Current	150mA
Power Connection	2.1mm DC Socket
Dimensions	203 x 119 x 48mm

Options Available

PART CODE	DESCRIPTION
BAL604	4Ch Active Balun Receiver
BAL654	4Ch Active Balun Transmitter

Other Products To Consider



Mini 1ch Passive Baluns (Pair)
BAL102



2.1mm 500mA 12V DC Plug-in PSU
POW150

All specifications are approximate. System Q Ltd reserves the right to change any product specifications or features without notice. Whilst every effort is made to ensure that these instructions are complete and accurate, System Q Ltd cannot be held responsible in any way for any losses, no matter how they arise, from errors or omissions in these instructions, or the performance or non-performance of the equipment that these instructions refer to.

This symbol on the products and/or accompanying documents means that used electronic equipment must not be mixed with general household waste. For treatment, recovery and recycling please return this unit to your trade supplier or local designated collection point as defined by your local council.
WEE/CG078355

BAL654 Transmitter - Connections & Controls

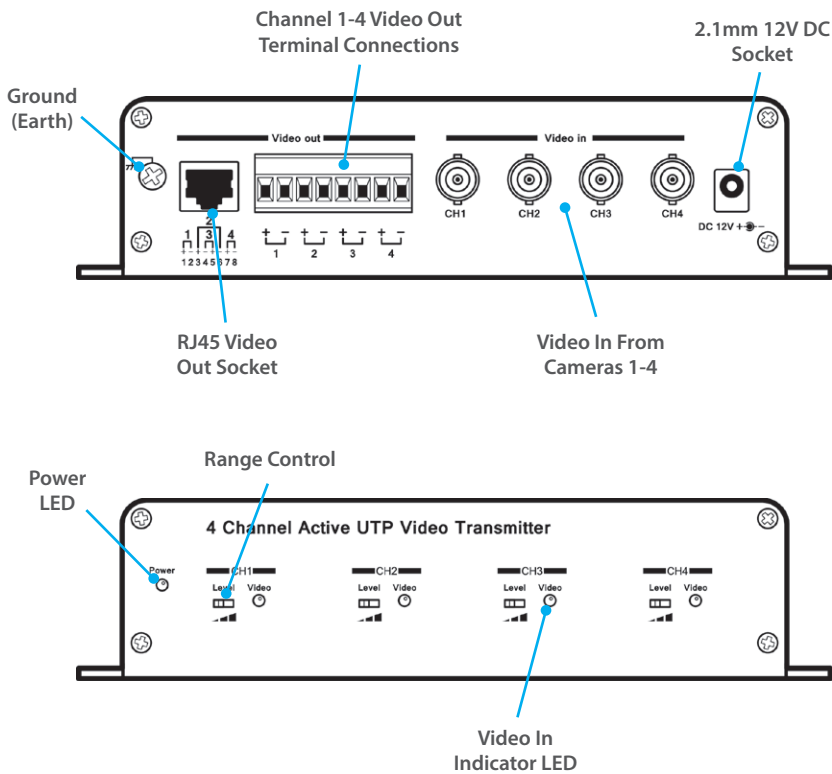

BAL654 Receiver - Controls

The level (range) for each channel is set with the slider on the side of the unit. The slider has 3 possible positions. The first position is for distances up to 1000m, the second position is used for distances up to 1500m and the final positions is for distances of up to 2000m as shown below.

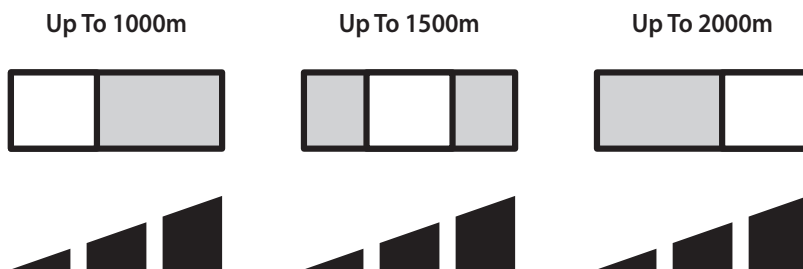

For more information on pairing passive and active baluns see online tip 317 ▶▶▶



Features

- Transmit Up To 2000m
- 2.1mm 12V DC Socket (150mA)
- BNC Video Connections
- Twisted Pair & RJ45 Connections
- Brightness & Sharpness Control
- Range Control

Specification

FUNCTION	SPECIFICATION
Bandwidth	8 MHz
Video Connections	BNC Sockets
CAT5 Connections	Terminal Strips Or RJ45 Sockets
Max Distance	2000m
Power	12V DC
Current	150mA
Power Connection	2.1mm DC Socket
Dimensions	203 x 119 x 48mm

Options Available

PART CODE	DESCRIPTION
BAL604	4Ch Active Balun Receiver
BAL654	4Ch Active Balun Transmitter

Other Products To Consider



Mini 1ch Passive Baluns (Pair)
BAL102



2.1mm 500mA 12V DC Plug-in PSU
POW150

All specifications are approximate. System Q Ltd reserves the right to change any product specifications or features without notice. Whilst every effort is made to ensure that these instructions are complete and accurate, System Q Ltd cannot be held responsible in any way for any losses, no matter how they arise, from errors or omissions in these instructions, or the performance or non-performance of the equipment that these instructions refer to.

This symbol on the products and/or accompanying documents means that used electronic equipment must not be mixed with general household waste. For treatment, recovery and recycling please return this unit to your trade supplier or local designated collection point as defined by your local council.
WEE/CG0783SS

Transmitting Via Twisted Pairs

When transmitting video via CAT5 twisted pairs, you must only use 1 twisted pair per channel and the polarity must be replicated on both baluns as shown below.

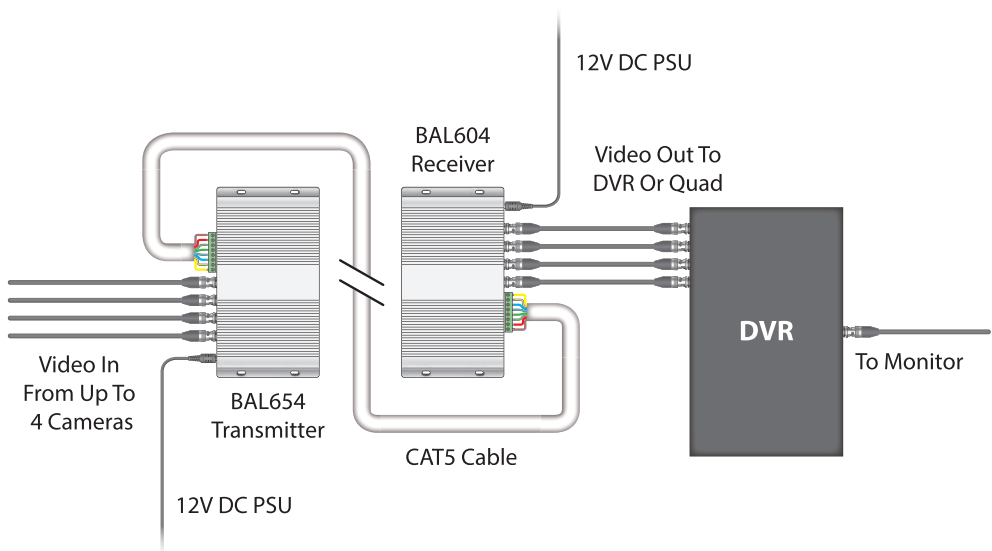
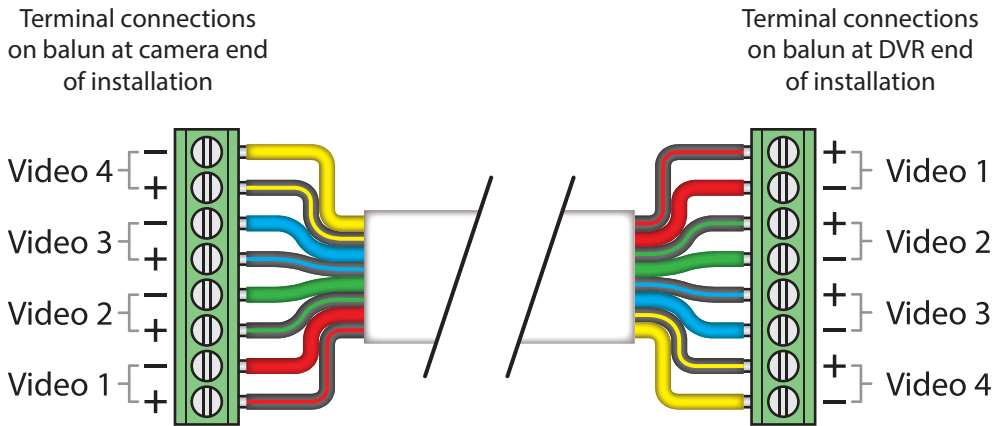

Transmitting Via RJ45

RJ45 cables are usually supplied with pre-wired RJ45 plugs. If you are wiring your own RJ45 plugs the wires must be connected to the pins as shown below.

CCTV CAT5

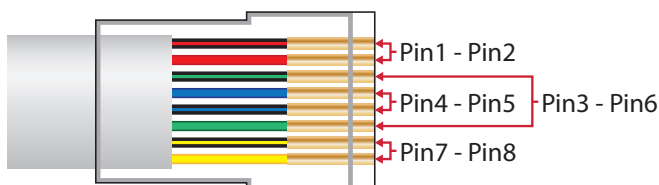

Features

- Transmit Up To 2000m
- 2.1mm 12V DC Socket (150mA)
- BNC Video Connections
- Twisted Pair & RJ45 Connections
- Brightness & Sharpness Control
- Range Control

Specification

FUNCTION	SPECIFICATION
Bandwidth	8 MHz
Video Connections	BNC Sockets
CAT5 Connections	Terminal Strips Or RJ45 Sockets
Max Distance	2000m
Power	12V DC
Current	150mA
Power Connection	2.1mm DC Socket
Dimensions	203 x 119 x 48mm

Options Available

PART CODE	DESCRIPTION
BAL604	4Ch Active Balun Receiver
BAL654	4Ch Active Balun Transmitter

Other Products To Consider



Mini 1ch Passive Baluns (Pair)
BAL102



2.1mm 500mA 12V DC Plug-in PSU
POW150

All specifications are approximate. System Q Ltd reserves the right to change any product specifications or features without notice. Whilst every effort is made to ensure that these instructions are complete and accurate, System Q Ltd cannot be held responsible in any way for any losses, no matter how they arise, from errors or omissions in these instructions, or the performance or non-performance of the equipment that these instructions refer to.

This symbol on the products and/or accompanying documents means that used electronic equipment must not be mixed with general household waste. For treatment, recovery and recycling please return this unit to your trade supplier or local designated collection point as defined by your local council.

WEE/CG078355

Continued On Next Page ►►►

Standard CAT5

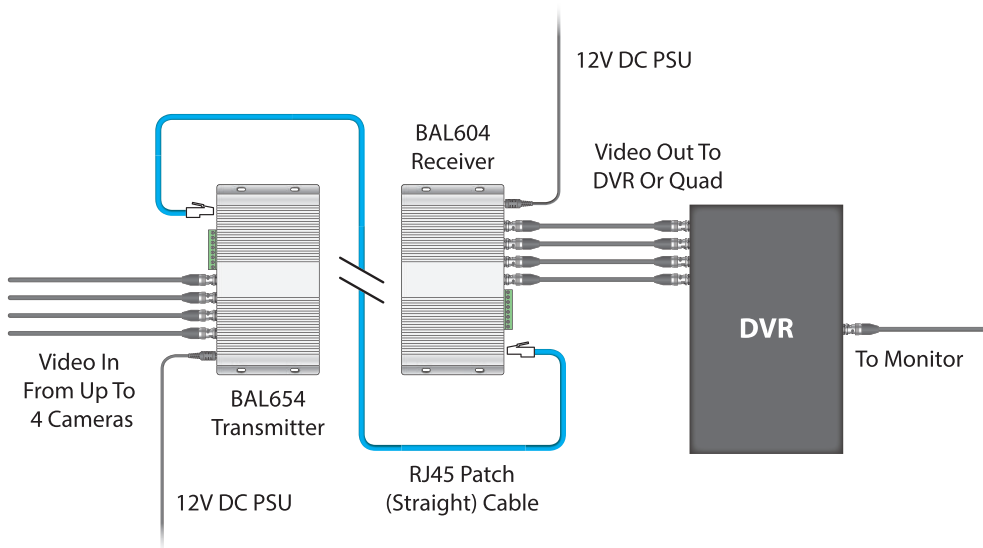
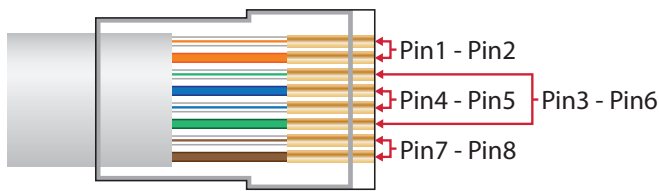

Fault Finding

Baluns are incredibly reliable. This means if the balun does not work when it is installed you really need to investigate the installation thoroughly.

No Picture

1. The wrong core colours have been used in the wrong order, re-check the connection order.
2. There is no power to the camera or the camera is not working. The baluns can only send a video signal down the cable if the video signal is actually there. **Make sure the camera is producing a picture using a test monitor.**
3. The cable is damaged or there is an open circuit or short caused by stretching, clipping or when dragged in. Replace.
4. No power or insufficient power to the balun.

Poor Picture

1. The camera is not working properly. The baluns can only send a GOOD signal down the cable if the camera is producing a GOOD picture to start with. **Make sure the camera is producing a picture using a test monitor.**
2. If you have the polarity of the CAT5 the wrong way around or use two cores from two different pairs you will get unpredictable results so please change.

Features

- Transmit Up To 2000m
- 2.1mm 12V DC Socket (150mA)
- BNC Video Connections
- Twisted Pair & RJ45 Connections
- Brightness & Sharpness Control
- Range Control

Specification

FUNCTION	SPECIFICATION
Bandwidth	8 MHz
Video Connections	BNC Sockets
CAT5 Connections	Terminal Strips Or RJ45 Sockets
Max Distance	2000m
Power	12V DC
Current	150mA
Power Connection	2.1mm DC Socket
Dimensions	203 x 119 x 48mm

Options Available

PART CODE	DESCRIPTION
BAL604	4Ch Active Balun Receiver
BAL654	4Ch Active Balun Transmitter

Other Products To Consider



Mini 1ch Passive Baluns (Pair)
BAL102



2.1mm 500mA 12V DC Plug-in PSU
POW150

All specifications are approximate. System Q Ltd reserves the right to change any product specifications or features without notice. Whilst every effort is made to ensure that these instructions are complete and accurate, System Q Ltd cannot be held responsible in any way for any losses, no matter how they arise, from errors or omissions in these instructions, or the performance or non-performance of the equipment that these instructions refer to.



WEE/CG078355

This symbol on the products and/or accompanying documents means that used electronic equipment must not be mixed with general household waste. For treatment, recovery and recycling please return this unit to your trade supplier or local designated collection point as defined by your local council.