

CCTVMuleTM 2 Instructions

**"Send 2 Video Signals
Down 1x Co-ax Cable..."**

...with a **CCTVMuleTM**



CCTVMULE 2 2 Video signals down 1 co-ax.

- 12V DC
- Up to 2 videos down co-ax*
- No need for extra cables*
- Audio transmission*
- Up to 200mtrs*
- Easy to setup

***It's the easy way to add extra
cameras to an existing installation!***

* as per instructions

Mule2 Instructions
Order Code: **MULE002**

Instructions - Instructions - Instructions

CCTV Mule Instructions



Carries multiple video signals even audio down **ONE** RG59 cable!

The CCTV Mule makes it easy to add extra cameras to existing installations, you save installation time and reduce the cost of buying and installing more cable.

The Mules work in pairs. One Mule combines the video signals to transmit them down 1 single co-ax, the other Mule then reconstructs the individual video signals at the remote end. A low-cost, easy solution that offers huge installation benefits and opportunities to add extra cameras.

The clever electronics of the CCTV Mule also allow it to carry audio along the same co-axial cable. You can even carry one video signal in one direction and one in the other direction!

The CCTV Mules need a 12V power supply at both ends but other than that, it's a really simple device to use, with no real configuration to do.

Step 1 - decide on the operation mode you require the Mule2 to work in...

It has the following 4 operation modes...

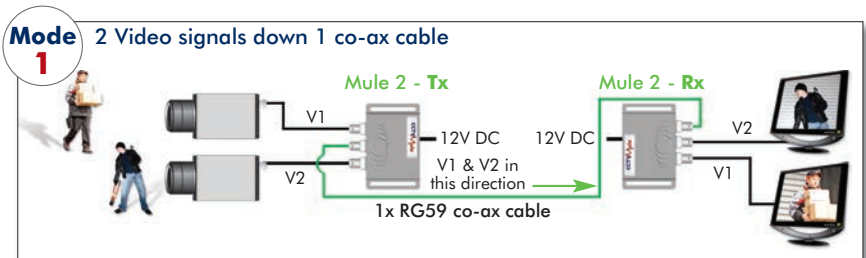

2 Instructions - Instructions - Instructions

CCTV Mule Instructions

Mode 2 1 Video signal in one direction, 1 video signal in the opposite direction.

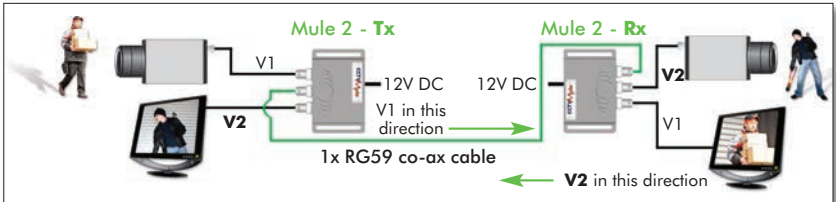

Mode 3 1 Video signal and 1 audio signal.

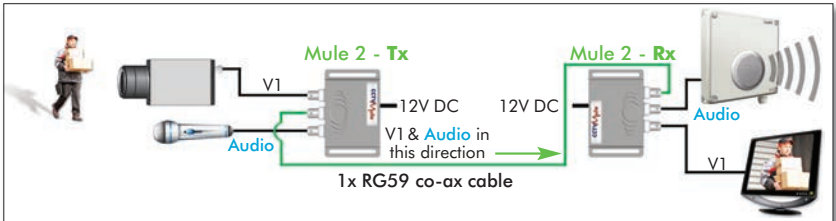

Mode 4 1 Video signal in one direction, 1 audio signal in the opposite direction.

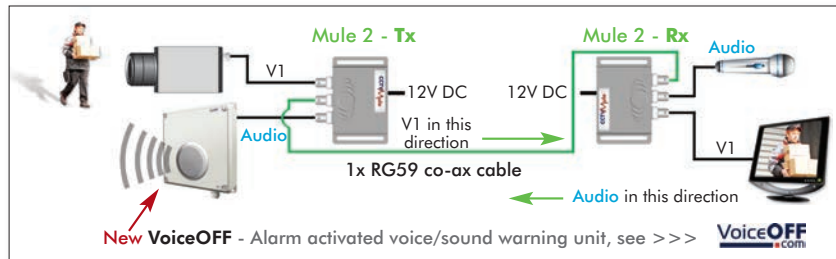

CCTV Mule Instructions

Step 2 - identify the relevant connections on the Mule2.

Connections - TX Transmitter

Each CCTV Mule is clearly marked on the power side as: **Tx** - Transmitter

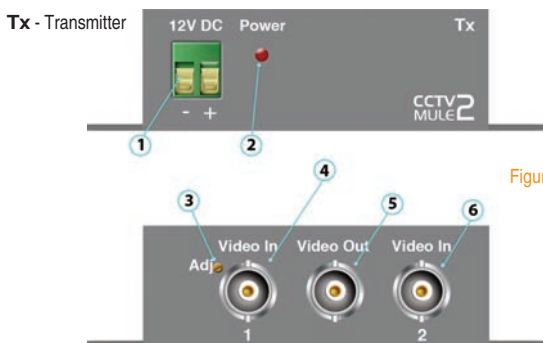

Figure 1

Tx - Transmitter unit has the following connections;

1. Power Input 12v D.C Only
2. Power L.E.D
3. Video Input Brightness Adjust
4. Channel 1 Video Input
5. Video Output to Mule Receiver
6. Channel 2 Video Input

Connections - RX Receiver

Each CCTV Mule is clearly marked on the power side as: **Rx** - Receiver

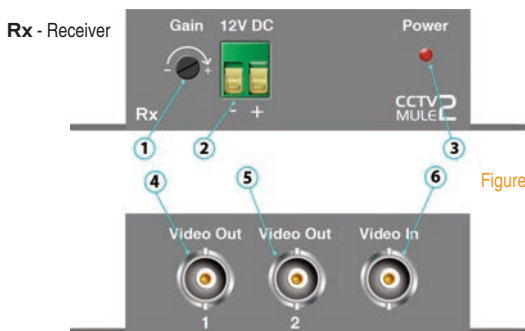

Figure 2

Rx - Receiver unit has the following connections;

1. Gain Control Switch
2. Power Input 12v D.C Only
3. Power L.E.D
4. Channel 1 Video Output
5. Channel 2 Video Output
6. Video Input from Mule Transmitter

CCTV Mule Instructions

Step 3 - fasten the unit to a wall

Installation

The units have wall mount fixings lugs either side for internal installation however for external installation the Mules **MUST** be installed in a suitable IP rated enclosure such as the BOX420 (figure 3).



Figure 3

Step 4 - power the units.

Powering the Units

The Mules require a 12v power supply to power the units, so you will require 2 power supplies. One for the transmitter and one for the receiver.

The PSU for the transmitter needs to be capable of supplying 12v D.C. @ 125mA continuously. The PSU for the receiver needs to be capable of supplying 12v D.C @ 120mA. Please ensure you use a fully regulated power supply or you risk damaging the Mules.

The Mules have a green 2 Pin connector that connects power to the units, both the Tx and Rx are clearly marked with the correct connection polarity. The red core is +12V and the black is 0v. See figures 4 and 5.

Please make sure that you check the polarity of the power supply that you are using to ensure the power is connected correctly. Once power is applied to the Mules the power LED will light up and stay lit.

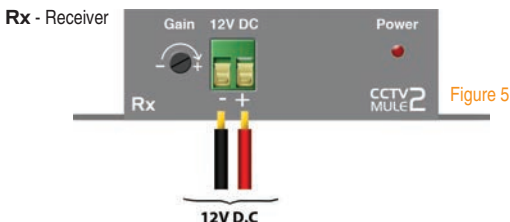
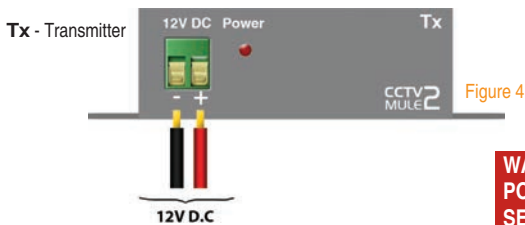

CCTV Mule Instructions

Step 5 - set up your chosen mode.

Operation Mode Setup

Mode 1 2 Video signals down 1 co-ax cable

The Mule2 allows 2 separate video signals to be sent down 1 co-ax cable allowing 1 extra CCTV camera to be added to an existing system. Figure 6 shows a diagram of how mode 1 is configured.

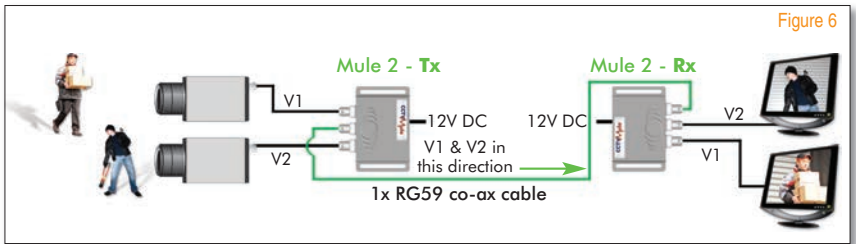

Tx - Transmitter

1. Connect your 2 video input signals into the 'Video In' ports 1 & 2 (figure1, 4 & 6)
2. The RG59 co-ax cable connects to the 'Video Out' port (figure1, 5), the maximum length for this cable is 200 metres.
3. You can adjust brightness of the video inputs if required by turning the grub screw (figure 1, 3) with a screwdriver clockwise and anticlockwise.

Rx - Receiver

1. The RG59 co-ax cable from the transmitter connects to the 'Video In' port (figure2, 6) of the mule receiver.
2. Connect your video cables from the 'Video Out' ports marked 1 and 2 (figure 2, 4 & 5) to your video in inputs on the back of your 2 LCD Monitors.
3. If you find the video quality is low when coming out of the receiver, you can use the 'Gain' control knob (figure 2, 1) to fine adjust the video image. This is especially useful when transmitting over distance.

CCTV Mule Instructions

Operation Mode Setup

Mode 2

1 Video signal in one direction, 1 video signal in the opposite direction.

Mule2 can also transmit a CCTV video signal in reverse. This great feature is an added bonus where wirefree is not an option due to site conditions such as trees and other obstacles in the way, especially useful if you don't have access to run any more cables. Figure 7 shows a diagram of how mode 2 is configured.

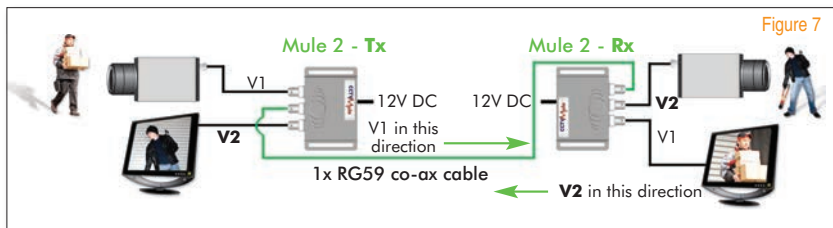

Tx - Transmitter

1. Connect the video input signal into the 'Video In' port 1 (figure 1, 4).
2. Connect an LCD monitor to the 'Video In' port 2 (figure 1, 6).
3. Connect the RG59 co-ax cable into the 'Video Out' port (figure 1, 5) the maximum length is 200 metres.

Rx - Receiver

1. Connect the RG59 co-ax cable from the transmitter to the 'Video In' port (figure 2, 6) of the receiver.
2. Connect an LCD monitor into the 'Video Out' port 1 (figure 2, 4) of the receiver.
3. Connect a video input signal like a camera into the 'Video Out' port 2 (figure 2, 5).

CCTV Mule Instructions

Operation Mode Setup

Mode
3

1 Video signal and 1 audio signal.

The Mule2 can also send an extra audio signal down the RG59 allowing 1 camera signal and 1 audio to be sent back to a monitor. There's no need to add extra cable to the existing RG59 co-ax cable as all this can be done with the Mule2. Figure 8 shows a diagram of how mode 3 is configured.

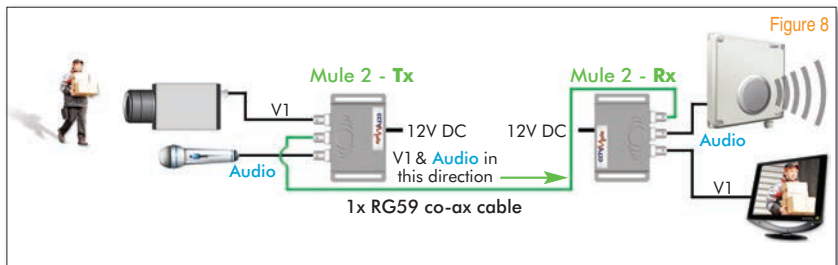

Tx - Transmitter

1. Connect the video input signal into the 'Video In' port 1 (figure 1, 4).
2. Connect an audio input device such as a microphone into 'Video Out' port 2 (figure 1, 6) of the transmitter.
3. Connect the RG59 co-ax cable into the 'Video Out' port (figure 1, 5) the maximum length is 200 metres.

Rx - Receiver

1. Connect the RG59 co-ax cable from the transmitter to the 'Video In' port (figure 2, 6) of the receiver.
2. Connect an LCD monitor into the 'Video Out' port 1 (figure 2, 4) of the receiver.
3. Connect an audio output device such as the VoiceOff into the 'Video Out' port 2 (figure 2, 5).

CCTV Mule Instructions

Operation Mode Setup

Mode 4

1 Video signal in one direction, 1 audio signal in the opposite direction.

The Mule2 is capable of transmitting audio in the reverse direction to 1 video camera signal. This mode works especially well in an existing installation where 1 of the cameras could be converted into a tannoy system using the VoiceOff. No additional cabling would be required to complete this setup.

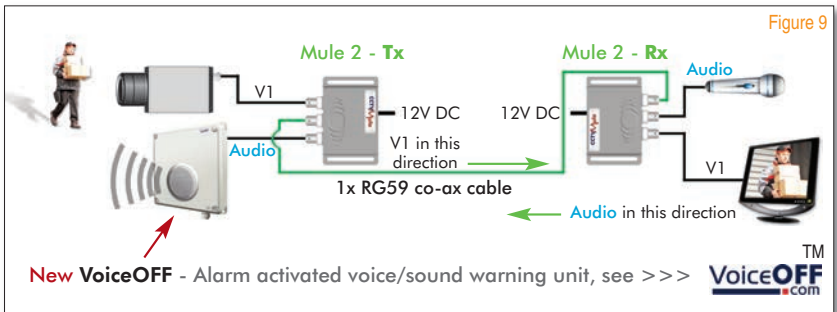

Tx - Transmitter

1. Connect the video input signal into the 'Video In' port 1 (figure 1, 4).
2. Connect an audio output device such as the VoiceOff into 'Video In' port 2 (figure 1, 6) of the transmitter.
3. Connect the RG59 co-ax cable into the 'Video Out' port (figure 1, 5) the maximum length is 200 metres.

Rx - Receiver

1. Connect the RG59 co-ax cable from the transmitter to the 'Video In' port (figure 2, 6) of the receiver.
2. Connect an LCD monitor into the 'Video Out' port 1 (figure 2, 4) of the receiver.
3. Connect an audio input device such as microphone into the 'Video Out' port 2 (figure 2, 5).

CCTV Mule Instructions

Troubleshooting



Q.1 I have power to both Mules but I can not get any video out of them. I have all the cameras connected and outputs connected to the DVR.

A.1 Check the Mules are connected the correct way around. The transmitter Mule (TX) should have the camera inputs connected to it and sited at the camera end. The receiver Mule (RX) should have the video outputs connected to the DVR and should be sited at the DVR end. Make sure that you have video going in to the TX mule using a test monitor.

Q.2 I have no video output and no power light lit.

A.2 Check the power supply is connected correctly to both Mules and outputting 12v D.C. Ensure the positive cable is connected to the positive port (+) and the negative cable is connected to the negative port (-) (figure 1 & 2).

Q.3 The output videos are very grainy and poor quality.

A.3 You will need to adjust the gain control by turning the 'Gain' control switch on the Mules (figures 1 & 2). This is done with a flat blade screwdriver, turn clockwise a fraction on the RX and review the video output again this may need a few turns to fully improve video quality. Remember that the maximum cable length is 200mtrs.

Q.4 I have my audio device connected to the TX Mule but no audio is coming out at the receiver end.

A.4 Ensure that the audio input is in 'Video In 2' (figure 1, 6) on the transmitter (TX) Mule as this is the only port that will transmit audio. Check the audio output device at the receiver (RX) end is in 'Video Out 2' (figure 2, 5). Also make sure your audio source is working ok.

Q.5 My video going into the TX Mule is clear and bright but the video coming out of the RX Mule is dark.

A.5 Try adjusting the video brightness control. See step 2 diagrams. Also try adjusting the gain.

Q.6 I can't get any video out of the units and I have my RG59 co-ax cable connected to 'Video In' of the TX.

A.6 Connect the RG59 co-ax cable to the 'Video Out' port on the TX Mule and connect the other end to the 'Video In' port on the RX Mule. You can not use any other port on the Mules as these two ports are for the transmission of the video & audio between the pair of Mules. Make sure the cable is 200m or less and good quality at least RG59 specification.

Q.7 I have all my inputs and outputs connected, the video going into the TX Mule is clear but the video coming out of the RX Mule is very poor. My cable run between both mules is over 200 metres.

A.7 The maximum cable run between the Mules is up to 200 metres using RG59. You may achieve longer distances using higher grades of cable.

Other Great CCTV Products

CCTV Mule Range

Also available in 4 way - the Mule4

Send 4 Video signals down 1 Co-ax cable

...with a **CCTV Mule™**



Even audio & data!

CCTV MULE4

4x Video In

1x RG59 OUT

5 Operation Modes!

Mode 2

3 Video signals in one direction, 1 RS485 signal in the opposite direction.

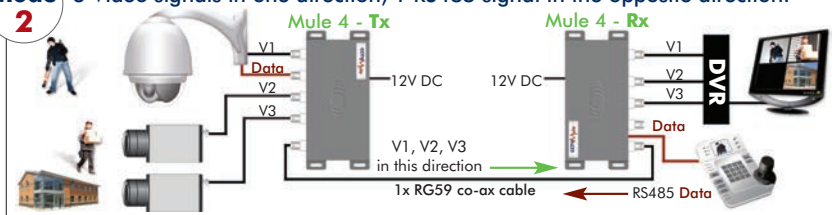

MULE004	TX	RX
Voltage	12 V DC	
Current Consumption	200mA	350mA
Video Inputs	4x BNC	1x BNC
Video Outputs	1x BNC	4x BNC
Video Quality	D1 @ 25FPS - Every Camera	
Gain Control	For different cable lengths	
Operation Modes	5	
Cable Required	RG59 or better	
Max Cable Length	200 Metres	
Size	175 x 110 x 30mm	

- 12V DC
- Up to 4 videos down co-ax*
- Data combiner*
- Audio transmission*
- Up to 200mtrs*
- Easy to setup

* as per instructions

CODE	DESCRIPTION
MULE004	Mule4 Tx & Rx

For more info see:
www.cctvmule.com

Other Great CCTV Products

Other items to consider...

VoiceOFF™ MK2

For more info go to:
www.VoiceOff.com



With **RS232** Input triggers up to **9999** sounds!!



plus **20** alarm inputs *trigger*
20 user recordable warnings!

The new **VoiceOff MK2** is an alarm activated voice or sound warning unit that has 20 separate alarm inputs to *trigger up to 20* different sound recording files and with the new added feature of an RS232 input *can trigger up to 9999 sounds!!*

Alarm activations can be triggered from an internal or external PIR, break beam detectors, panic button, keyfob or from a DVR detecting video motion in a camera's footage.

Voice warning messages can be downloaded or recorded yourself in a MP3 format onto a removable SD card stored in the VoiceOff unit and used to deter intruders or even welcome visitors. Similarly sound files such as a police siren or dog barking can be used to deter unwanted visitors in vulnerable areas.

When used in conjunction with the alienDVR range, the **VoiceOff** can be activated remotely over the internet when a suspicious sighting has been made.

Specification	
20 x Alarm Inputs	Speaker output 8W 80 ohms
SD card compatible (supplied)	MP3 file compatible
8-18V AC/ DC	12V DC 120mA Standby
200mA max (depending on volume)	Wall Mounting Fixing Lugs
Ivory ABS Housing, Rated IP65	Max Size: H234 x W188 x D85
(inc. gland/speaker)	

CODE	DESCRIPTION
VOX200	VoiceOff Unit

Features

- Accepts up to 20 alarm inputs
- Powerful 10 Watt Output
- Voice & sound files stored on a removable SD card
- Can be activated automatically using alarm inputs
- Can be used as a talkback amp with DVRs
- RS232 connection to PC or DVR
- Stores & plays 9999 sounds
- Voice & sound files available from www.voiceoff.com or scan the QR code >>>

VoiceOFF™
www.VoiceOff.com



Use the VoiceOff for...



VideoMitters™ Digital Transceivers

*Monitor & control
video & sound from
one location to
another without wires!*



Up to 1.2Km Range*

The VideoMitters are a break through in the transmission of video signals.

By digitising the video & audio signals, far superior performance can be achieved in transmission distance and received image & audio quality.

The innovative VideoMitters can also transmit IR data in the reverse direction to the transmitted audio and video signals allowing any device that uses a hand held IR remote to be controlled from a different room or location without wires.

Simple, effective and low cost, the VideoMitter is an installer's dream product saving money on cabling and labour with outstanding results.



Order Code:
MITKIT

Tx and Rx unit with antennas, 2x Phono-BNC Converter
2x AV cables and 2x IR extension leads

Specification:

2.4Ghz Frequency
Up to 20 pairs on 1 site
Auto channel selection
12V DC - Terminal Strip
Current - 200mA
300mA + 12V PSU required
Video Connection - 1x Phono Input
Audio Connection - 2x Phono Inputs
IR Socket
Antenna - RP SMA Female
Unit Size-113 x 95 x 25mm

*Additional antennas
available!*



— outperforms others —

visit: www.VideoMitter.com

Or scan the QR code
with your phone to take
you to the website!



CODE	DESCRIPTION
MITKIT	Tx & Rx Units

*Additional antennas available for 1.2KM.

Other Great CCTV Products

Keep vital evidence secure from tampering or theft by fitting your DVR into a KitVault lockable enclosure...

For more info go to:
www.kitvault.com

Hinged Lid for easy installation and engineer access

Wall & Desk bothholes for permanent fixing to wall/shelf

Hot Air Out!

Cool Air In!



How fan is fitted inside

Easy fit fan kits (12V DC) for extra cooling of stored equipment

Choice of 3 fan vents for full flexibility to suit the on-site conditions

Lockable to prevent unauthorised access

Tough window panel for easy monitoring of equipment

Ext Measurements:
W520x H150 x D550mm

Extra deep design for easy rear cable access to suit most DVRs

The CCTV Code of Practice 2008 that forms part of the Data Protection Act states that recorded CCTV images must be, "securely stored, where only a limited number of authorised persons may have access to them".

The KitVault is designed to house CCTV equipment such as DVRs to keep the equipment not just secure from unauthorised tampering by staff and visitors but also from theft of the equipment itself. In addition to the lockable door, the enclosure can be bolted to a shelf or desk and wall to prevent removal.

Finished in an attractive silver and graphite finish and built from 1.7mm steel, the enclosure blends easily into commercial environments. Fan vents situated on both sides and the rear allow the quick fitting of one or more of the 12V DC fan kits available to allow cool air to be circulated around the electronic equipment stored inside it.

The KitVault houses all the DVRs in this booklet as well as most on the market with internal measurements of: W515 x H130 x D525mm.

All NEW Design!

Extra room at rear for DVR connections

Fan Option for Cooling!

CODE	DESCRIPTION
CCT245	DVR KitVault
FAN012	12V Fan Kit



Scan the QR code with your phone to take you to the website!

Other Great CCTV Products

Introducing the Who is Watching Me Signage Solutions No Overprinting Required!



**FAST, EASY, LOW COST,
SMART & CONVENIENT**

Each sign is pre-printed with a unique serial number, so overprinting is a thing of the past.

1-Fit it!!

Pre-drilled holes speed up installation and rounded corners help comply with H&S regulations.



2-Register it!!

You register your unique "Sign ID" to your contact details at an online data base so the public are able to contact you as is required by the Data Protection Act.



Fit it - Register it - No need to overprint it!

Visit:
www.WholsWatchingMe.org

Or scan the QR code
with your phone to take
you to the website!



CCTVMuleTM Specifications



**Send 2 Video signals down
1 co-ax cable with a Mule2**

For further information or help please contact us by email:
support@cctvmule.com

or visit us online at: www.cctvmule.com



Or scan the QR code
with your phone to take
you to the website!



WEE/CG0783SS

This symbol on the products and/or accompanying documents means that used electronic equipment must not be mixed with general household waste. For treatment, recovery and recycling please return this unit to your trade supplier or local designated collection point as defined by your local council.

© Copyright 2012

Technical Specification

MULE002	Transmitter TX	Receiver RX
Voltage	12 V DC	
Current Consumption	125mA	120mA
Video Inputs	2x BNC	1x BNC
Video Outputs	1x BNC	2x BNC
Video Quality	D1 @ 25FPS - Every Camera	
Gain Control	For different cable lengths	
Operation Modes	4	
Cable Required	RG59 or better	
Max Cable Length	200 Metres	
Size	91 x 88 x 28mm	

All specifications are approximate. CCTVMule.com reserves the right to change any product specifications or features without notice. Whilst every effort is made to ensure that these instructions are complete and accurate, CCTVMule.com cannot be held responsible in any way for any losses, no matter how they arise, from errors or omissions in these instructions, or the performance or non-performance of the equipment that these instructions refer to.



Instructions - Instructions - Instructions