

NiteDevil WDR Hi-Res Dome

The *NiteDevil* Dome Camera produces high quality images and works in very low light conditions down to 0.0008 Lux. It has many features including a solid aluminium waterproof base, 3D axis mounting inner bracket for wall mounting, a SONY SuperHad CCD and a 2.8mm ~ 12mm varifocal lens. An OSD facility provides options for wide dynamic, High Sensitivity BLC, motion detection, privacy masking and other camera functions.

Models Available

CAM771 600TVL, 12VDC

CAM772 600TVL, 12VDC/24VAC

Electronic Features

- ✓ 1/3" SONY SUPER HAD CCD II
- ✓ Low illumination down to 0.0008 Lux
- ✓ Menu for Motion Detection & camera setup
- ✓ Wide Dynamic Range Function.
- ✓ High Sensitivity Backlight Compensation



Mechanical Features

- ✓ Vandalproof & Weatherproof
- ✓ 3 Axis 3D built-in bracket
- ✓ Vari-focal 2.8 ~ 12mm Auto DC Iris Lens
- ✓ Aluminium housing with Polycarbonate Smoked Cover
- ✓ Two Allen screws to stop tampering

Mounting the Camera

The camera is for mounting on a wall, ceiling or outdoor fascia board. Note that this camera has a 3D gimble allowing wall mounting or ceiling mounting. Note that fitting the screws into a ceiling will require support for the screws. N.B Please be aware that when refitting camera, the dome cowling does not obscure the lens.

Powering the Camera

CAM771

The dome requires a 12V DC regulated power supply. Connections are polarity sensitive so therefore ensure that the positive and negative cables are connected correctly. The camera is provided with a fly lead with a 2.1 jack connector for power. This camera draws a maximum of 130mA at 12v DC. Ensure that a regulated power supply is used if using 12vDC and allow adequate headroom i.e only use a power supply with a minimum rating of 200mA.

CAM772

This dome is dual voltage. It will work on 12vDC or 24vAC. Connections are not polarity sensitive so therefore power connections can be either way round. The camera is provided with a fly lead with a 2.1 jack connector for power. This camera draws a maximum of 130mA at 12v DC or 90mA at 24vAC. Ensure that a regulated power supply is used if using 12vDC and allow adequate headroom i.e only use a power supply with a minimum rating of 200mA.

Connecting the camera to control equipment.

The dome camera comes with a fly lead for video out. To reduce installation time the video out lead is terminated into a male BNC connector. This allows the installer to effortlessly connect the camera to control equipment via a female BNC-BNC lead. A special setup joystick controller is located on the side of the PCB board and this allows access to the OSD menu. A special socket is located to the right of the joystick controller to connect an optional test video monitor lead.

RS485 Connection

The RS485 connection allows access to the menu using a keyboard or DVR PTZ operation using a 95 call to open menu and select options using near, far, open and closed. Red needs to be connected to Transmit + and Black to Transmit -.

Cable Diagram

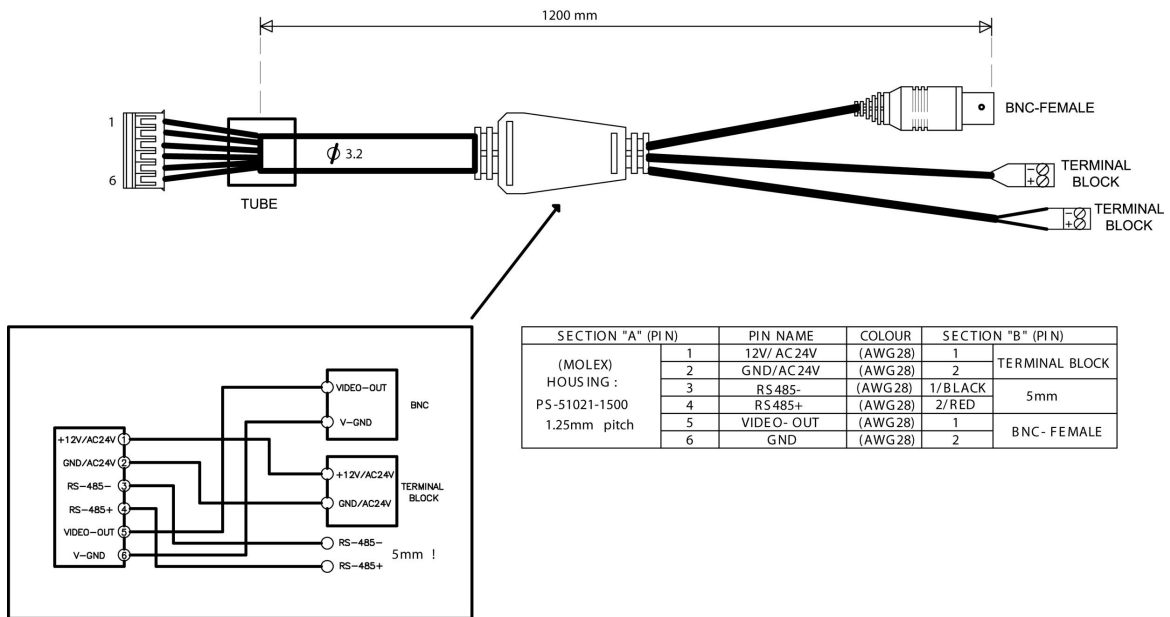

Setup Instructions

1. First adjust the camera position using the 3 way gimble. The complete camera can be moved in the metal housing. Hold the camera at either side of the camera bracket where the locking screws are located. **Do not grip the camera lens.**

2. Adjust the vertical angle by releasing the two side screws and the moving the camera up or down.

3. Re-tighten these screws when the adjustment has been made.

4. A separate small adjustment can be made holding either side of the plastic fitting behind PCB and moving sideways.

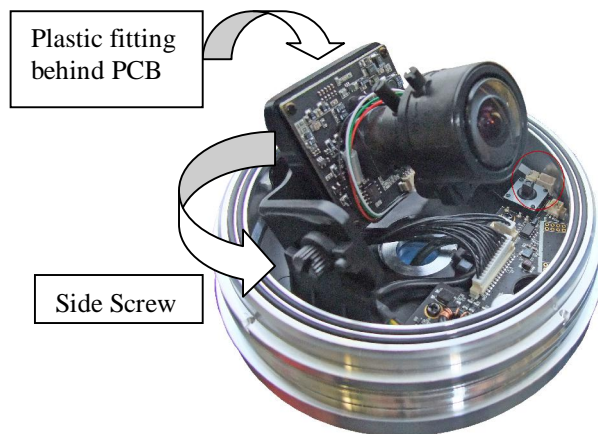

5. Now adjust the zoom and focus settings using the controls shown.

6. Loosen the controls using a small screwdriver. You may find it easier to set the Zoom control first and then adjust the Focus.

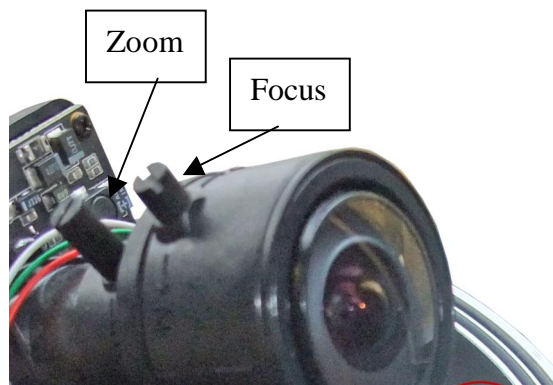

7. Retighten the Zoom and Focus controls.

Ceiling Mount

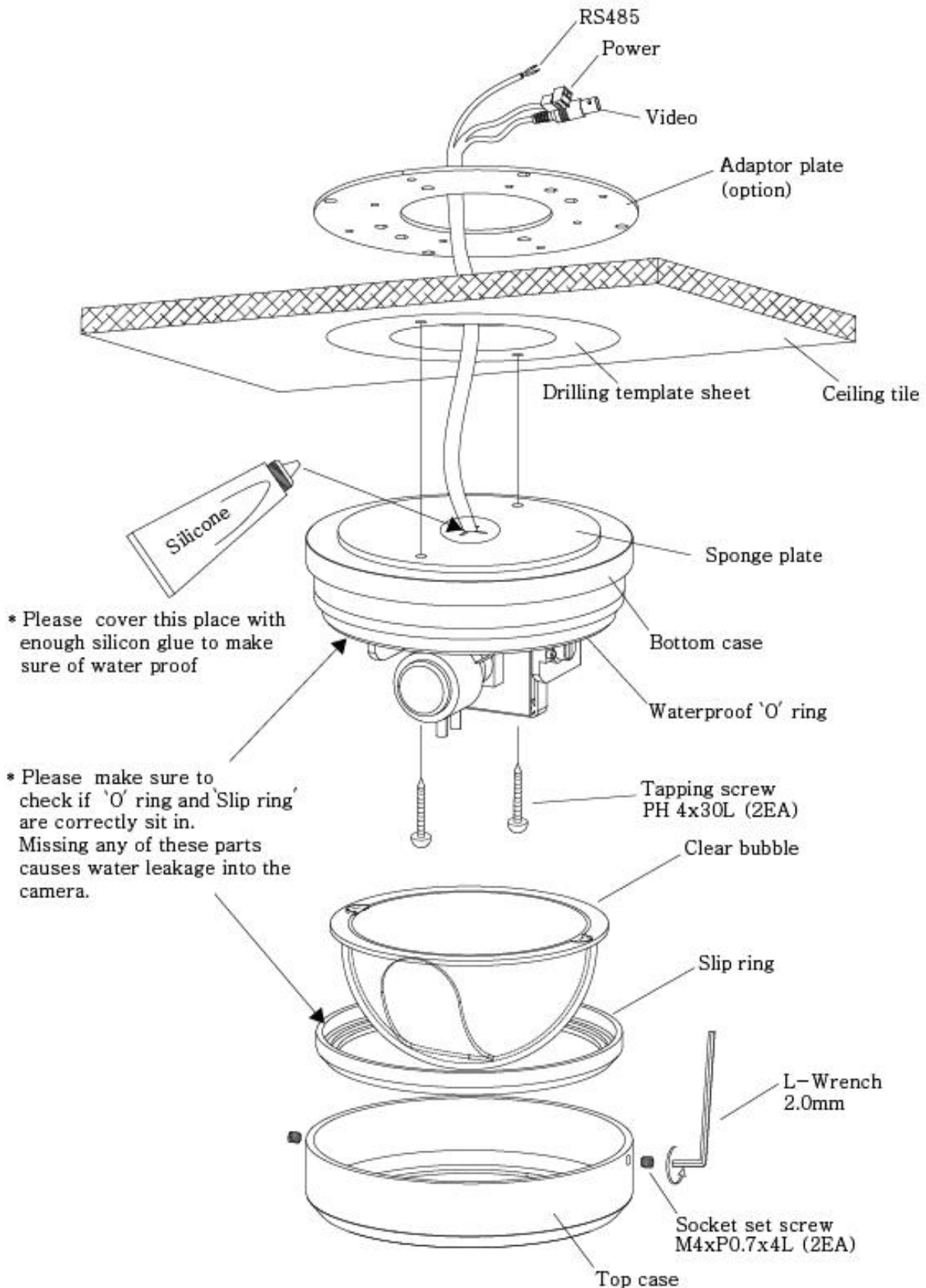

1. Place drilling template sheet onto a ceiling surface and drill holes through the marked positions.
2. Put a sponge plate onto the bottom surface of the Dome. This prevents the camera from water or dust ingress. Please put sufficient silicon onto the cable hole to cover gaps between cable and sponge plate.
3. Fix the Dome base with tapping screws.
4. Set up camera functions.
5. Fix the dome cover /slip ring /top case with 'L' wrench and screws.

Wall Fitting

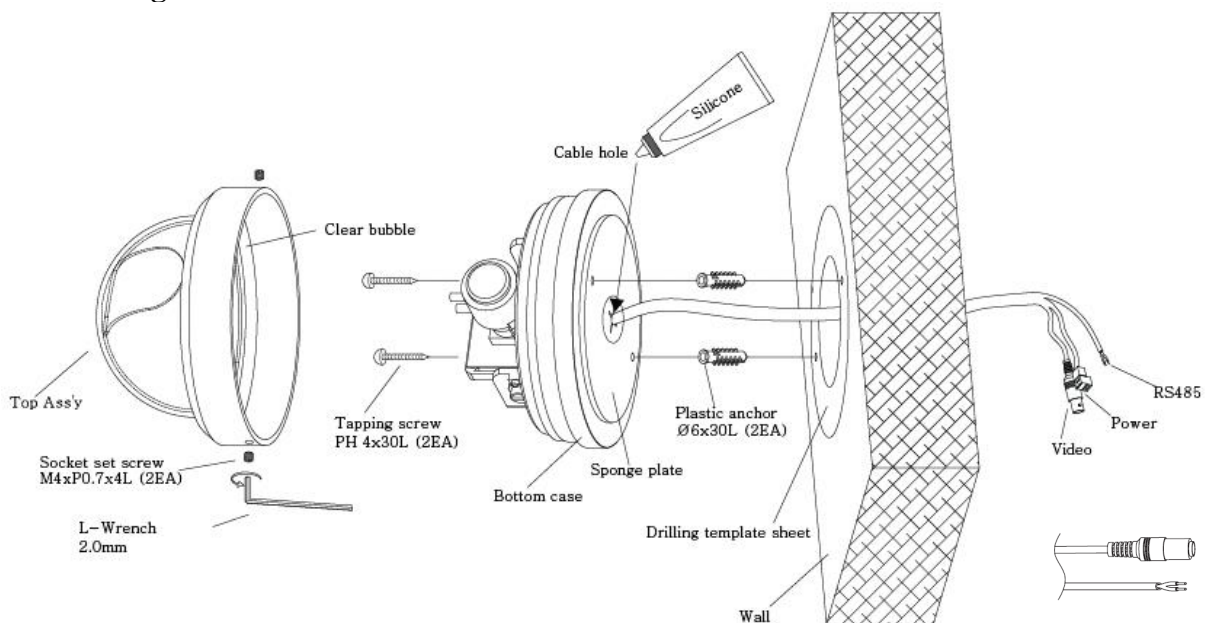

- 1) Place a drilling template sheet onto wall surface and drill holes through the marked positions.
- 2) Put a sponge plate onto the bottom surface of the Dome. This prevents the camera from water or dust ingress. Please put enough silicon onto the cable hole to cover gaps between cable and sponge plate.
- 3) Fix the Dome base with Tapping screws.
- 4) Rotate the camera using 3-Axis mechanism in order to capture objects in upright position and setup function.
- 5) Fix the Dome cover with screws by using 'L' wrench supplied

OSD (On Screen Display) Function.

Remove the dome cover using the Allen key supplied to access the PCB board for entering the menu.

1. If you want to use the test monitor lead supplied, plug it into the Test Monitor Connection shown in diagram. The spare short lead is a spare extension.
2. The OSD menu is accessed by first pressing down the centre button (SET Button).
3. Move button upwards to move down menu.
Move button downwards to move up menu
Move button right to move right
Move button left to move left
Press button down to Enter change

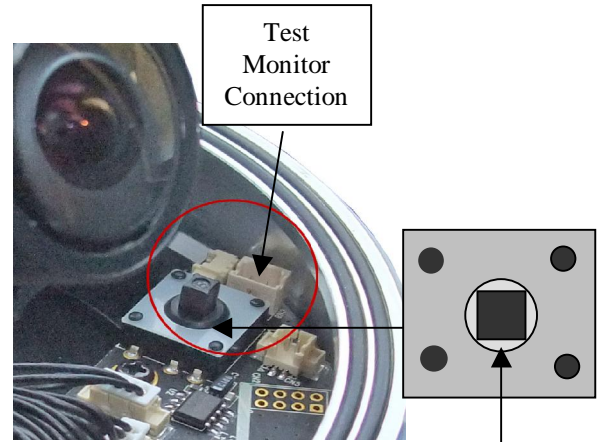

Menu Set Button Press Down

The following menu will be displayed on your monitor on pressing SET button (Joystick controller):

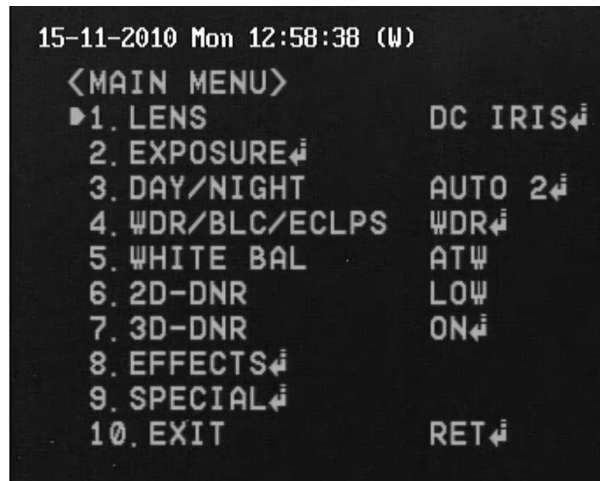

Menu Structure Functions

LENS	DC IRIS	MANUAL			
EXPOSURE	AGC INITIAL SET	SHUTTER PREVIOUS	SENSE-UP		
DAY NIGHT	AUTO 2	AUTO 1	NIGHT	DAY	
WDR/BLC/ECLPS	WDR	OFF	ECLPS	BLC	
WHITE BAL	ATW	MANUAL	PUSH	COL-ROLL	
2D-DNR	LOW	HIGH	MIDDLE	OFF	DISABLED
3D-DNR	ON	OFF			
EFFECTS	DZOOM MODE SHARPNESS	IMAGE FRZE CR GAIN	D-EFFECT CB GAIN	COLOR INITIAL SET	CONTRAST PREVIOUS
SPECIAL	CAM NAME L/L SYNC	MOTION DET. MONITOR TY.	PRIV. MASK FACTORY SET	LANGUAGE COMM SET	STABILIZER PREVIOUS
EXIT					

NOTE: All items with the icon allow you to access a submenu by pressing the SET button down. Any item showing - - - icon functionality is not available on this camera.

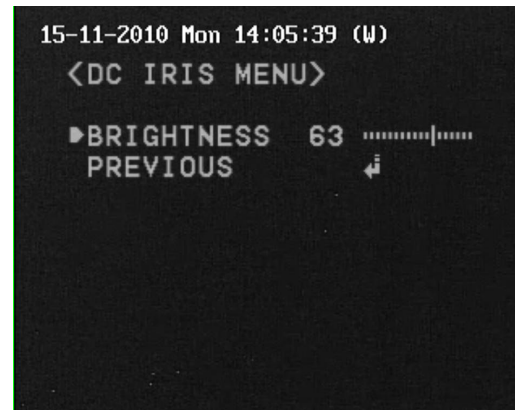
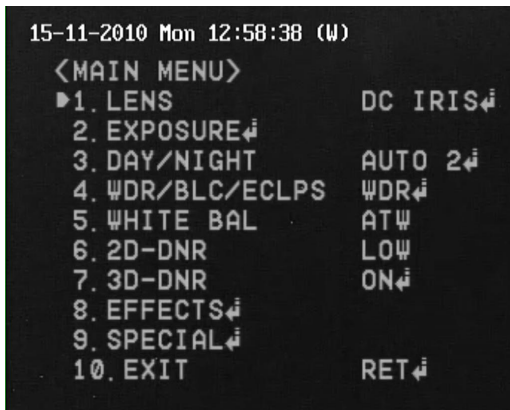

LENS

This option allows the screen brightness to be adjusted. Range of brightness setting is 0 ~ 100.

EXPOSURE

AGC Low / Middle / High / OFF

You can adjust the gain level, but the brighter the screen the higher the noise level.

SHUTTER The shutter speed is set at AUTO, x2, x3, x4, x5, x6, x8, x10, x12, x14, x16, x24, x32, x64, x128, x256, x 512, 1/90000, 1/50000, 1/30000, 1/10000, 1/7000, 1/5000, 1/2500, 1/1600, 1/1000, 1/700, 1/500, 1/250, 1/160, A.FLK, OFF.

NOTE: Changing shutter speed affects brightness.

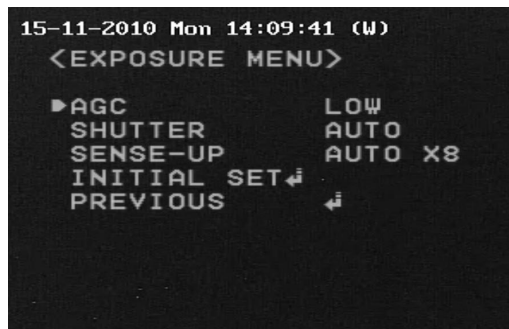

SENSE-UP When it is dark the camera automatically detects the light level and maintains a clear picture.

The following options can be set: OFF, AUTO x512, x256, x128, x64, x32, x16, x14, x12, x10, x8, x6, x5, x4, x3, x2.

NOTE: This function deactivates if AGC and/or DAY/NIGHT is switched off. Also the higher the setting, ghosting increases

INITIAL SET This option defaults this menu to manufacturer's settings.

PREVIOUS This returns to previous menu

DAY/NIGHT

AUTO 2

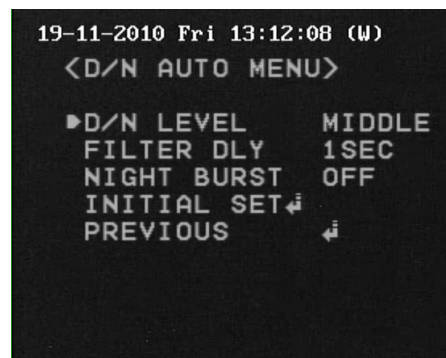
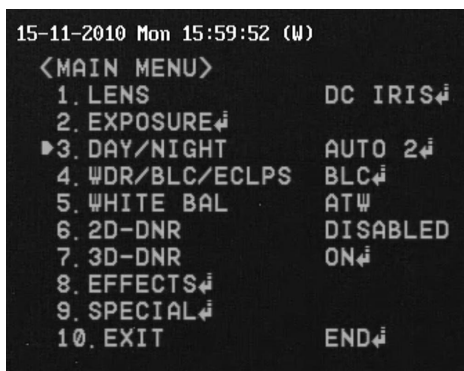

GENERAL INFORMATION ON THE DAY/NIGHT MENU

The AUTO function has two settings, AUTO 2 and AUTO 1. These functions allow colour pictures during the day and black and white pictures at night. This is normally the preferred option as this gives best pictures during day and night. If you are using the Wide Dynamic function you should use AUTO 1 otherwise use AUTO 2. If you use the COLOR option the pictures will remain in colour day and night but if there is not sufficient light, then you may experience grainy colour pictures at night, black and white or even no pictures at all. The NIGHT option displays only in black and white.

AUTO 2

D/N LEVEL Low / Middle / High

FILTER DLY Filter Delay. This allows the filter switch to be delayed. 1, 3, 5, 10, 15, 30 or 60 seconds. Default 1.

NIGHT BURST Off / On. When on reduces the effect of sudden darkness.

INITIAL SET This option defaults this menu to manufacturer's settings.

PREVIOUS This saves and returns to previous menu

AUTO 1

AUTO 1

IR WDR LEVEL Low / Middle / High / Off

IR WDR DEST 0, 1, 2, 3, 4, 5, 6

PREVIOUS This saves and returns to previous menu

DAY This option stays in colour. See General Info.

NIGHT This option stays in black & white. See General Info.



WDR / BLC / ECLPS

WDR

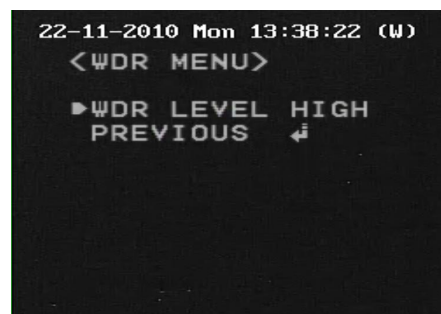
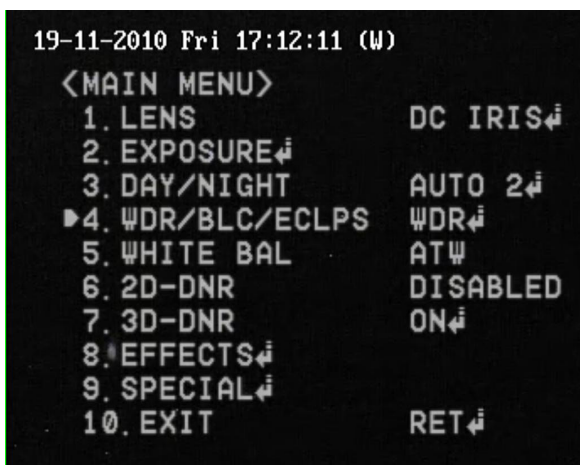

WDR Wide Dynamic Range
 If there is a bright and dark area, for example shaded area, displayed on screen, the D-WDR option can be set to even out the overall brightness. There are three options that can be selected, HIGH / MIDDLE / LOW



D-WDR OFF



D-WDR ON

PREVIOUS This saves and returns to previous menu

BLC Backlight Compensation



BLC Backlight Compensation

Backlight compensation balances strong light evenly across the video image. The options are: LOW / MIDDLE / HIGH. The BLC option allows the desired area in a picture to be viewed more clearly.

PREVIOUS This saves and returns to previous menu

ECLPS Eclipse option

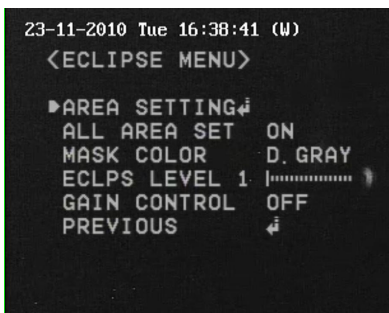

ECLPS Eclipse option allows the dimming of a light source. An area can be set to identify position of light source, and dimming can be adjusted using the Mask Color and ECLPS levels. Gain control can be switched on or off to see the effect of the dimming process.

OFF This switches off the Wide Dynamic, Backlight Compensation and Eclipse functions.

WHITE BAL White Balance

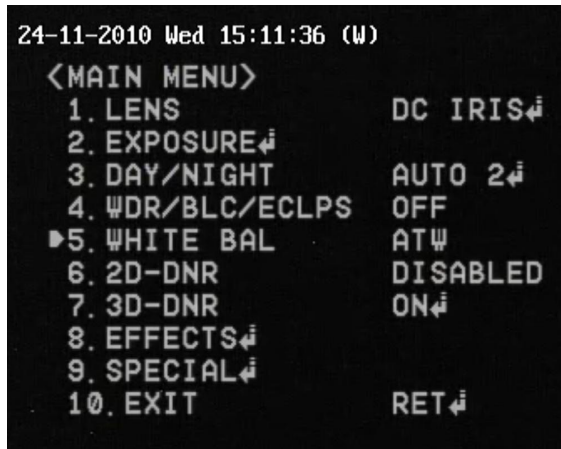

WHITE BALANCE Alters the background white balance

The following options can be selected:
 ATW, MANUAL, PUSH and COL-ROLL

ATW Select this when colour temperature is between 2500°K and 9800°K. Suitable for viewing objects with changing colour temperature.

MANUAL See menu below.

COLOR TEMP INDOOR or OUTDOOR

RED Set red colour -100 ~ +100 default 0

BLUE Set blue colour -100 ~ +100 default 0

INITIAL SET This option defaults this menu to manufacturer's settings.

PREVIOUS This returns to previous menu

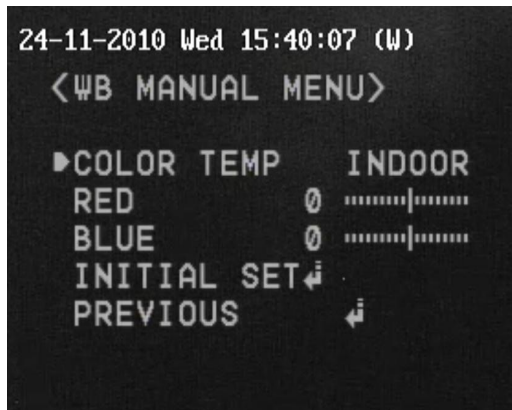

PUSH This option can be used to set white balance. Press once to set current white balance.

COL-ROLL Set when there is changing colour

2-DNR and 3-DNR

Methods for reducing noises of an image frame include a 2D noise reduction (2DNR) method and a 3D noise reduction (3DNR) method. Generally, the 2DNR method utilises multiple adjacent pixels in the present image frame to adjust the present image frame. The 3DNR method utilises multiple continuous image frames to adjust the present image frame. The 2DNR method has an obvious disadvantage, which leads the detail of an image to become blurry. Although the 3DNR method does not have the disadvantage of the 2DNR method, the 3DNR method has disadvantages of ghosts and greater hardware resource requirement.

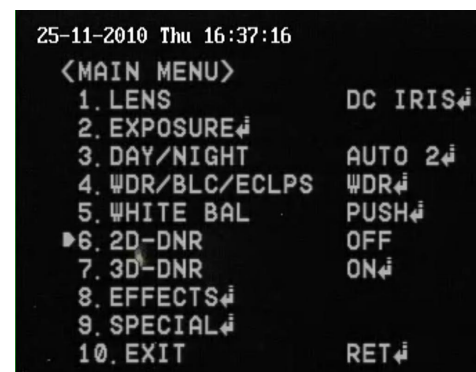

2-DNR This menu allows the following options High, Middle, Low, Disabled and Off.

3-DNR

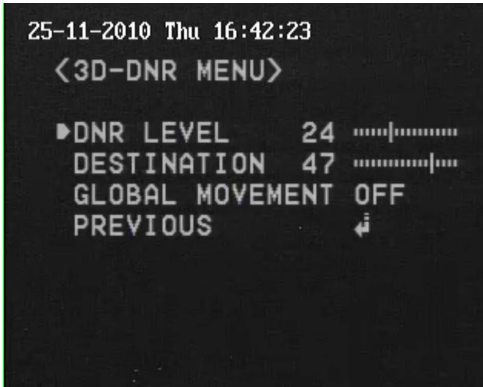

3-DNR This menu allows the following options OFF / ON

If selecting ON the menu on the left is displayed.

DNR LEVEL Set level of Digital Noise Reduction detection

DESTINATION Set level of Digital Noise Reduction

GLOBAL MOVEMENT Set to OFF / ON

PREVIOUS This returns to previous menu

EFFECTS

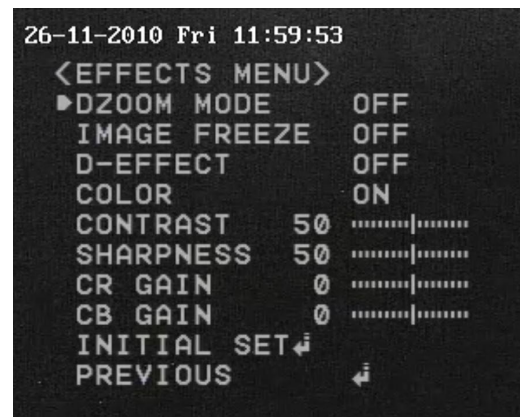
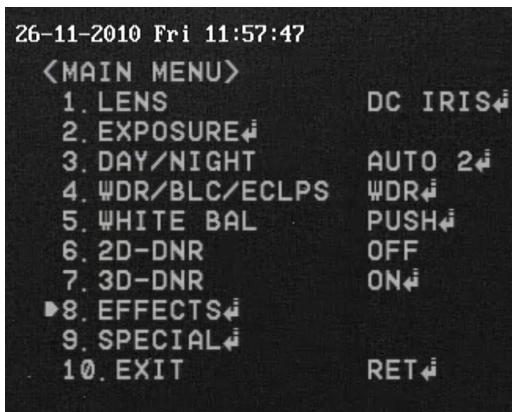

DZOOM MODE Digital Zoom mode. Options are OFF / ON. If switched to ON select DZOOM menu.

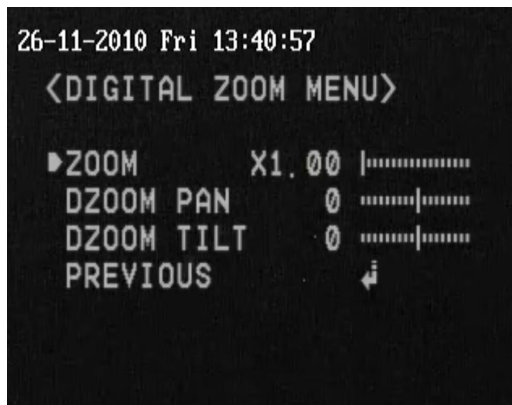

ZOOM Allows digital zoom size. Left click to select
Range is from x1 in stages up to x8

DZOOM PAN Set horizontal range for zoom

DZOOM TILT Set vertical range for zoom

PREVIOUS This returns to previous menu

IMAGE FREEZE Freezes image if set to ON. Default = OFF.

D-EFFECT



D-EFFECT

Allows horizontal and vertical flip.

OFF Normal view. Default setting.

ROTATE Upside Down & Right to Left

MIRROR Right to Left

V-FLIP Upside Down Right stays Right

PREVIOUS This returns to previous menu

COLOR Set to ON / OFF Changes from colour to black & white mode

CONTRAST Set contrast 0 ~ 100 Default 50

SHARPNESS Set sharpness 0 ~ 100 Default 50

CR GAIN Set Red colour -100 ~ +100

CB GAIN Set Blue colour -100 ~ +100

INITIAL SET This option defaults this menu to manufacturer's settings.

PREVIOUS This returns to previous menu

SPECIAL

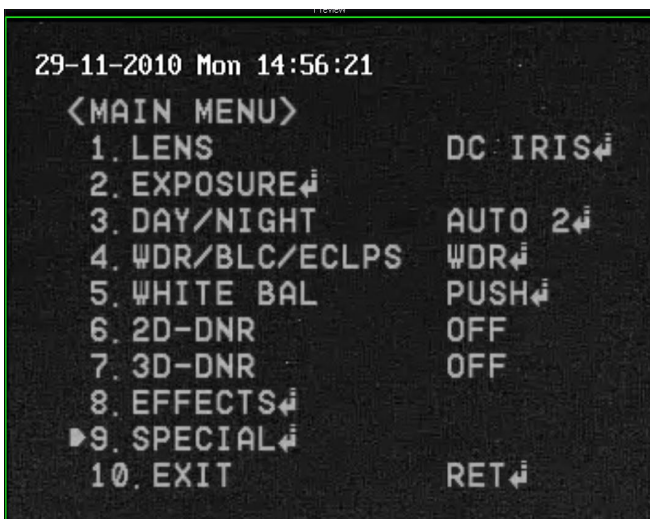

SPECIAL

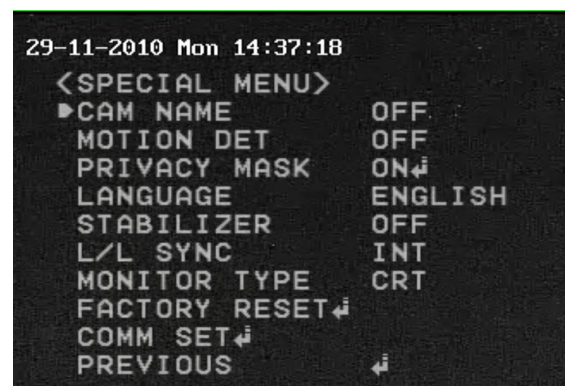

CAM-TITLE OFF / ON

This is the camera title option. Set this to ON by pressing the left or right direction keys and then pressing SET button

Use the four direction buttons to move to the desired letter and select the letter by pressing the SET button. Repeat to enter up to 15 letters. If you enter a wrong title move cursor to CLR and press the SET button to clear the complete title. If you enter an incorrect letter, select the letter by clicking on the left or right arrow and press the SET button to position over the incorrect letter, then select the correct letter and press SET.

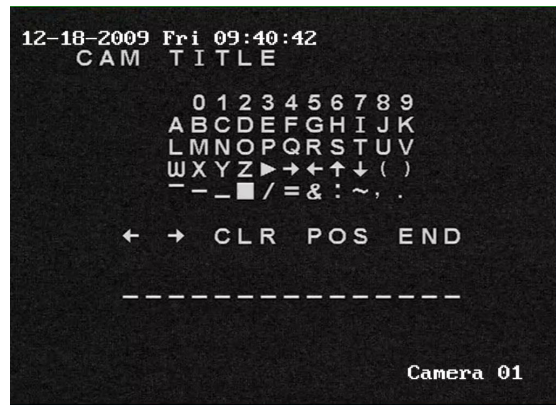

When the title is completed select POS and press SET.

The entered title now appears on the screen. Select the position where the title is to be displayed using the direction keys and then press SET button. If okay press END followed by SET to return to previous menu.

MOTION OFF / ON

The motion detection facility if set to ZONE STATE ON will display the words MOTION DETECTION whenever the camera detects movement. The motion can be selected in each of the 8 zones defined in the camera picture. The parameters available allow each of the eight areas to be selected for motion and sensitivity. You can set the width and height of the Zone area and move the area to MOVE X and MOVE Y positions. If there is movement in the Zone area selected and this is switched to ZONE STATE ON a display will be shown on the monitor : **MOTION AT : <n>** where n = Zone Number

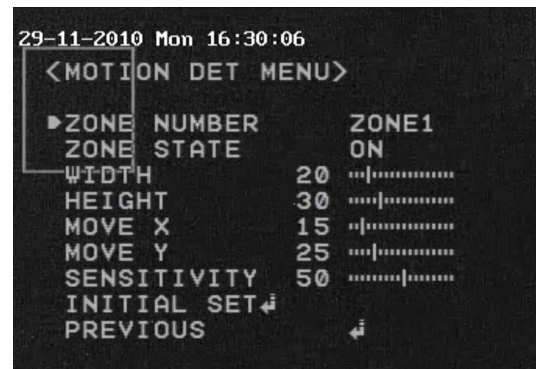

PRIVACY MASK OFF / ON

This function enables you to hide an area on the screen. Select this by pressing the SET button.

- MASK NUMBER** Select an area between 01 ~ 08
- MASK STATE** ON / OFF Switch OFF area required.

The remaining parameters allow each area size to be adjusted to requirements. To delete settings select INITIAL SET.

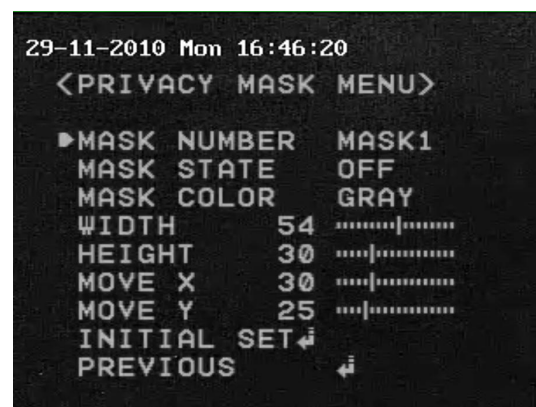

LANGUAGE ENGLISH / FRENCH / SPANISH
RUSSIAN / CHINESE

You can select from the above languages which will initiate 5 seconds later.

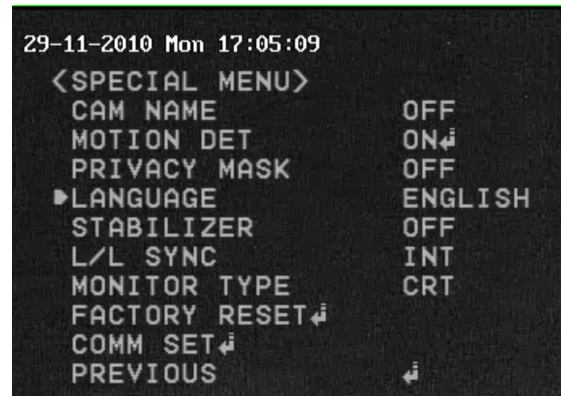

STABILIZER ON / OFF

L/L SYNC In areas where the AC power is 60Hz you can synchronise the output phase of camera using the power synchronisation function (Line Lock) without using a sync generator.

When using 12v DC, the SYNC menu is fixed to the INTERNAL (INT) sync mode.

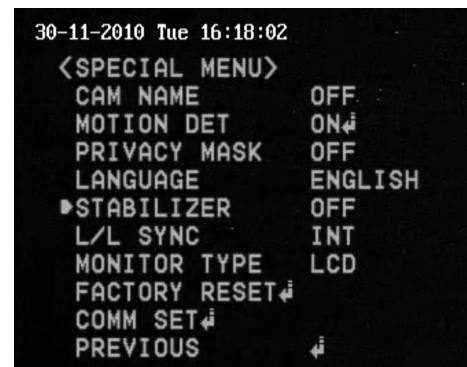

MONITOR TYPE LCD or CRT monitor

FACTORY RESET Reset to manufacturers settings

COMM SET

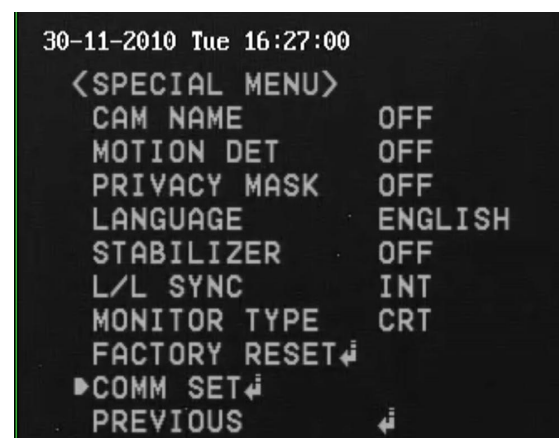
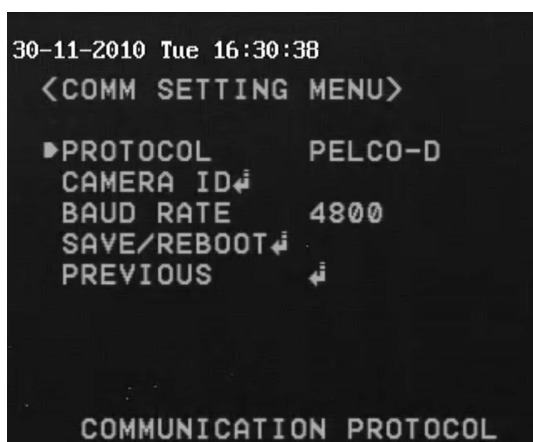

The RS485 connection allows access to the menu using a keyboard or DVR PTZ operation using a 95 call to open menu and select options using near, far, open and closed. Red needs to be connected to Transmit + and Black to Transmit -.

PROTOCOL PELCO-D

CAMERA ID

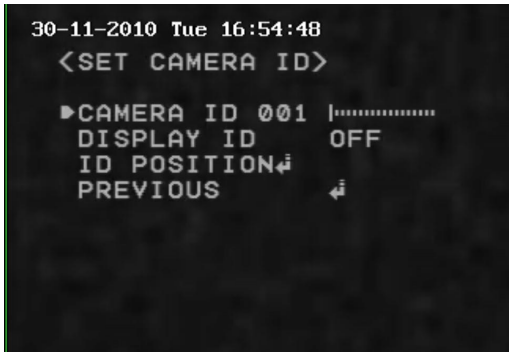

CAMERA ID Set ID number 000 ~ 255

DISPLAY ID OFF / ON If set to ON ID displayed on monitor

ID POSITION Enter and use direction keys to position display

PREVIOUS This returns to previous menu

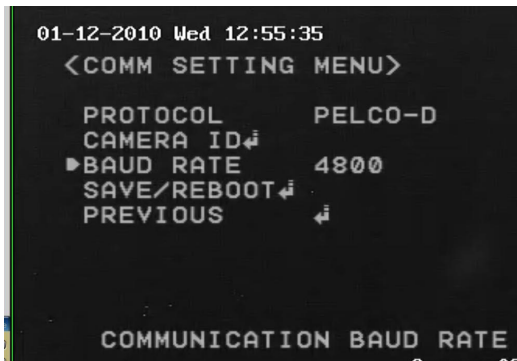

BAUD RATE Select from 4800 / 9600 / 19200 / 38400 / 57600

SAVE/REBOOT SAVE BAUD RATE & ID

PREVIOUS DISCARD BAUD RATE AND ID
This returns to previous menu

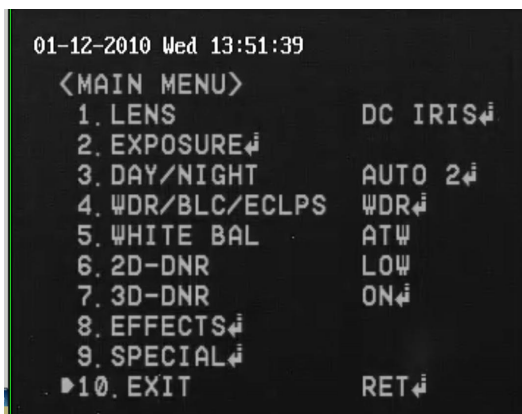

EXIT Enter to exit menu.

DIMENSIONS

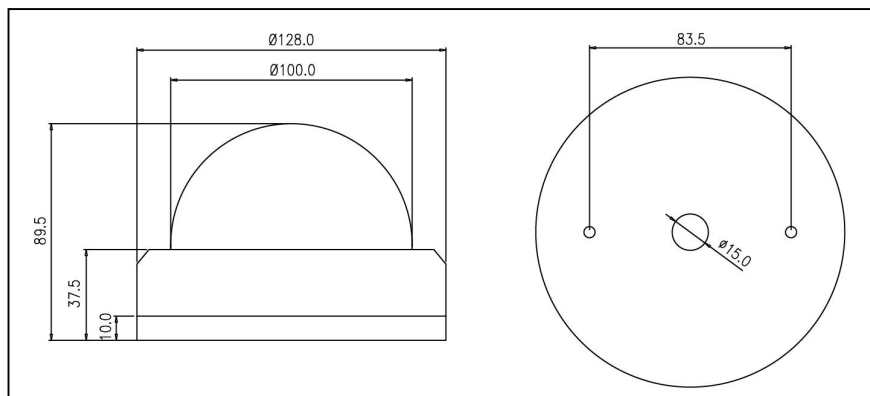

Special Features

Troubleshooting

- No screen display
 - * check power connection
 - * check video line
 - * check brightness of Auto Iris Lens
- Unclear video image
 - * check lens is clean
 - * adjust monitor contrast
 - * ensure display screen is not exposed directly to sunlight.
- Screen is dark
 - * adjust monitor contrast
 - * adjust brightness level of the Auto Iris Lens – Refer LENS settings
 - * adjust lens focus lever

Technical Specifications

Function	Specification	
Model	CAM771	CAM772
Power Source	12vDC 130mA	12vDC / 24vAC Dual Power 12vDC 130mA / 24vAC 90mA
Imaging Sensor	1/3" SONY Super HAD CCD II	
Gamma Correction	0.45	
Effective Pixels	PAL: 752(H) x 582(V)	
Signal System	PAL 625 lines	
Scanning system	2:1 Interface	
Gain Control	-6dB ~ 34dB Auto / Maximum by OSD	
S/N Ratio	More than 52 dB (AGC Off)	
Horizontal Resolution	Horizontal: 600 TVL Colour / 650 TVL Black & White	
Video Output Level	1.0 v p-p (75Ω, composite)	
Lens	Built-in DC Iris Vari-focal Lens (2.8 ~ 12mm)	
Minimum Illumination	0.0008 Lux (Sens-up x512) at F1.2, 0.1 Lux (Sens-up OFF) at F1.2	
Sync System	Internal	
OSD	Built-in(Multi-language support – English/French/Spanish/Russian/Chinese)	
Electronic Shutter Speed	PAL: (1/50 sec ~ 1/90,000 sec) / NTSC: (1/60 sec ~ 1/90,000 sec)	
White Balance	(1500°K ~ 11000°K) Auto	
2D/3DNR	Off / On (OSD selectable)	
WDR	Off / On (OSD selectable)	
Motion Detection	On/Off (8 zones)	
Sens-up	Off / 2x ~ 512x	
Digital Zoom	Off (x1 ~ x8.30)	
Privacy Masking	On / Off (8 zone selectable)	
White Balance	ATW / Col-Roll / PUSH / Manual	
Operational Temperature/Humidity	-10°C ~ +50°C / 0% ~ 90% RH	
Dimensions	Base diameter 128mm x 89.5mm Height	
Weight	Approximately 700g	

All specifications are approximate. nitedevil.com reserves the right to change any product specifications or features without notice. Whilst every effort is made to ensure that these instructions are complete and accurate, nitedevil.com cannot be held responsible in any way for any losses, no matter how they arise, from errors or omissions in these instructions, or the performance or non-performance of the equipment that these instructions refer to.



WEE/CG0783SS

This symbol on the products and/or accompanying documents means that used electronic equipment must not be mixed with general household waste. For treatment, recovery and recycling please return this unit to your trade supplier or local designated collection point as defined by your local council.