

**HDM220 HDMI KVM TX/RX**

This HDMI KVM (Keyboard, Video and Mouse) switch can control a DVR or NVR from a remote location up to 100 metres on CAT5E or 120 metres on CAT6. It can also control one or more computers from a single keyboard and mouse, and view them with audio on a single HDMI monitor.



The HDM220 consists of an HDM217 transmitter and an HDM216 receiver. These can be purchased individually as one transmitter can control a number of receivers.

Examples of use

The DVR/NVR could be installed in a locked server room and a monitor and mouse installed in a reception area where the DVR/NVR pictures could be viewed and mouse access available to the DVR. Alternatively a PC could provide HDMI to a monitor and the PC could be controlled from a mouse and keyboard.

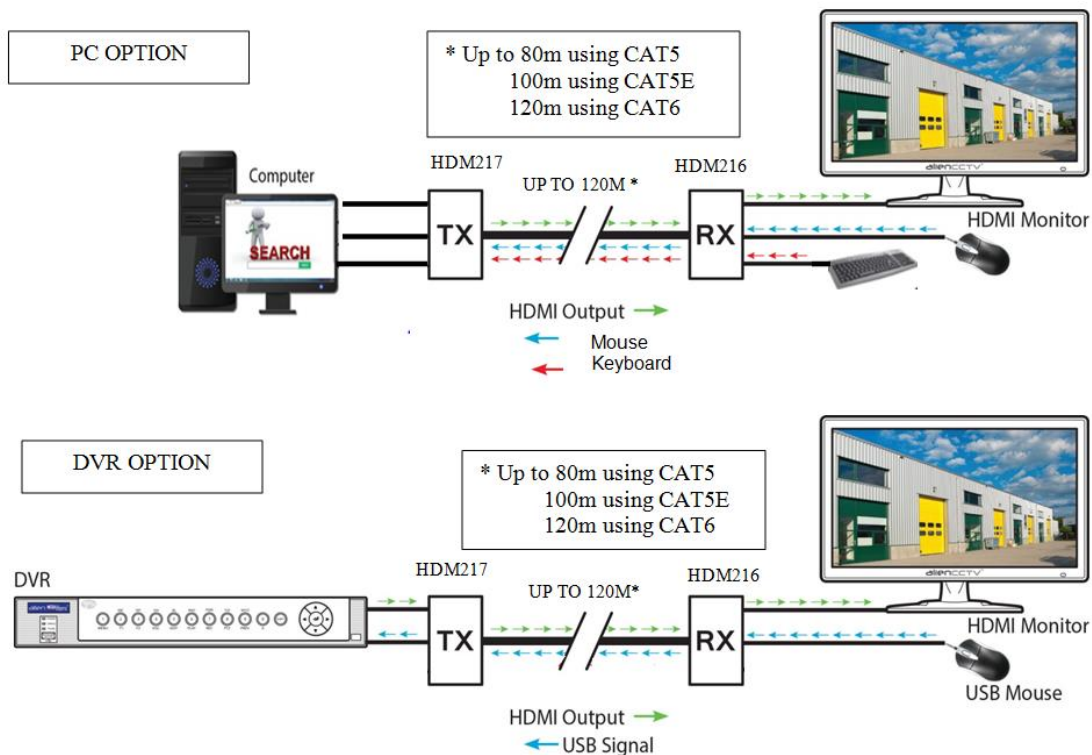

## List of HDM220 Components

- 1 x HDM217 Transmitter & USB lead
- 1 x HDM216 Receiver
- 2 x 5v DC 1A Power Supplies

## Installation Instructions

### HDM217 Transmitter

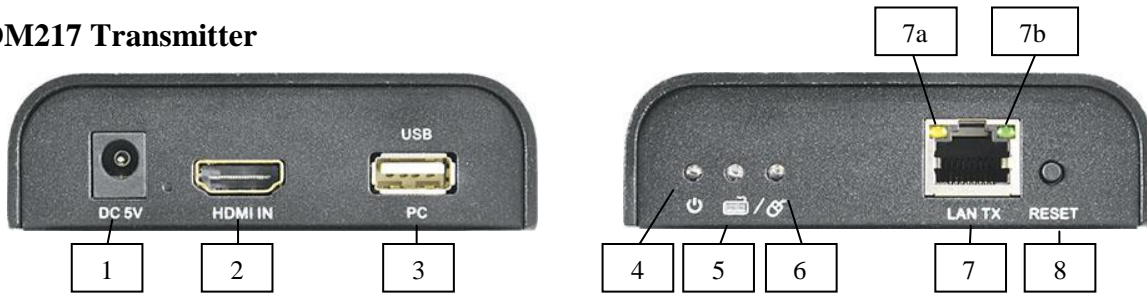

- |   |  |
|---|--|
| <ol style="list-style-type: none"> <li>1. 5v DC power input</li> <li>2. HDMI input port</li> <li>3. USB port to connect to PC<br/>(USB cable supplied 120cm)</li> </ol> | <ol style="list-style-type: none"> <li>4. LED Power indicator</li> <li>5. LED Keyboard indicator</li> <li>6. LED Mouse indicator</li> <li>7. LAN Transmit (7a / 7b LEDs)</li> <li>8. Reset button</li> </ol> |
|---|--|

### HDM216 Receiver

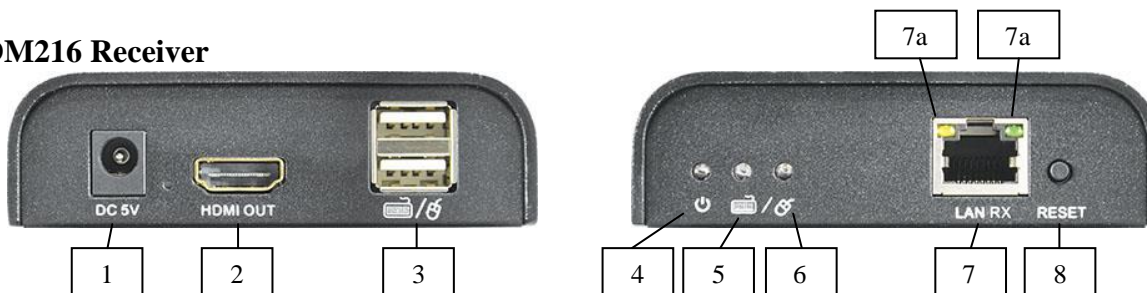

- |  |   |
|--|---|
| <ol style="list-style-type: none"> <li>1. 5v DC power input</li> <li>2. HDMI output port</li> <li>3. USB Dual input<br/>(Keyboard Input/Mouse Input )</li> </ol> | <ol style="list-style-type: none"> <li>4. LED Power indicator</li> <li>5. LED Keyboard indicator</li> <li>6. LED Mouse indicator</li> <li>7. LAN Receive (7a / 7b LEDs)</li> <li>8. Reset button</li> </ol> |
|--|---|

- a) Connect an HDMI cable from the DVR, PC, PS3 or DVD player etc. to the Transmitter. Ensure that HDMI cable is no longer than 5 metres for a 1080P input signal or 10 metres for a 720P input signal.
- b) Connect the HDMI cable output from the Receiver to the HDMI monitor/HD TV. Ensure that the HDMI cable run is no longer than 15 metres.
- c) Connect a network cable between the Transmitter and Receiver of no longer than 80 metres using CAT5, 100 metres using CAT5E or 120 metres using CAT6.
- d) Connect a 5vDC 1A power supply to the Transmitter and Receiver. The power LEDs should light up. When the signal LEDs light and flicker, the equipment is ready to use.

- e) If you are using a USB mouse or keyboard plug them into the USB ports on the Receiver. You will also need a USB cable fitted between the Transmitter and DVR, or item you are controlling with the mouse. A standard USB 90cm cable is also included.

The HDM217 Transmitter can be used with multiple HDM216 Receivers. The following is an example of one of the options.

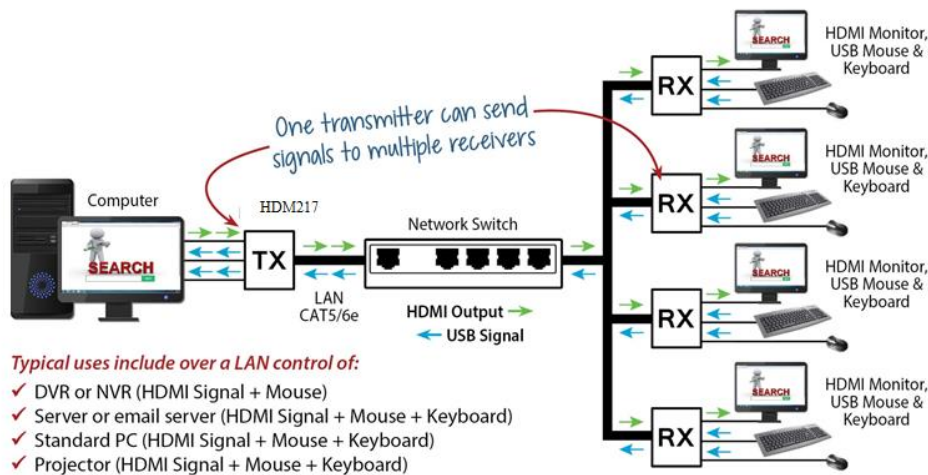

Note that when using on an office network, there may be network resource considerations, so in some instances it may be necessary to separate this functionality using a separate network switch.

### Troubleshooting

**Live Status:** When running correctly the Yellow LAN LED is flashing and the Green LED is on. If the Transmitter is not network connected, a message “Searching TX” displays. If network connected but no video input, a message “Check TX’s input signal” displays. Note that the speed of the flashing Yellow LAN LED will depend on the network resources available so may differ from one site and another.

#### Question 1: Yellow LED on LAN ports is flashing slowly?

Answer:

- 1) Ensure the video source is connected to the HDMI Transmitter and not Receiver;
- 2) Ensure the video source is an HDMI Signal that is supported on the HDM220;
- 3) Try a different HDMI Cable between the source device and the HDMI Transmitter.

#### Question 2: Yellow LED on LAN ports is flashing quickly but no display?

Answer:

- 1) Check the resolution from the HDMI source device agrees with the supported resolution of the display device;
- 2) Ensure that the HDMI Cable between the HDMI Receiver and the display device is connected properly.
- 3) Try a different HDMI Cable between the source device and the HDMI Receiver.

**Question 3: Yellow LED on LAN ports is not lighting up?**

**Answer:**

- 1) Ensure all cables are well connected;
- 2) Try a short network cable to confirm equipment is okay and problem is not cable length.

**Question 4: Abnormal or flashing colours displayed and cables are connected correctly**

**Answer:**

- 1) Please press the reset button on the HDMI transmitter and receiver;
- 2) Please make sure the network cable meets the IEE-568B standard.

**Question 5: USB does not work?**

**Answer:**

- 1) Check the USB device or mouse works in the source device;
- 2) Ensure the USB cables are properly connected;
- 3) Reset the HDMI transmitter or receiver.

**HDM220 Technical Specification**

HDMI Version	HDMI 1.3		
HDCP Version	HDCP 1.2		
Video Bandwidth	≤ 70Mbps		
Supported HDMI Resolutions	640*480@60Hz 1280*720@60Hz 1400-1050@60Hz	800*600@60Hz 1360*768@60Hz 1680*1050@60Hz	1024*768@60Hz 1440*900@60Hz 1920*1080@60Hz
Audio	PCM (44.1KHz, 48KHz)		
HDMI Connector	Type A, 19 pin, Female		
LAN Connector	RJ45		
Power Supplies	2 x 5vDC/1A		
Power Consumption	HDM217 Transmitter 700mA      HDM216 Receiver 700mA		
Power Connection on TX & RX	2.1mm DC Jack		
Network Connection	RJ45 cable CAT5/CAT5E/CAT6 max run 80m/100m/120m		
HDMI cable run to HDM217 Transmitter	If source 1080P max run 5 metres – if 720P max run 10 metres		
HDMI cable run from HDM216 Receiver	15 metres		
Operating temperature Range	0°C ~ +50°C		
Operating Humidity Range	10% ~ 95% (Non condensing)		
Transmission	One HDM217 TX can transmit video & audio to multiple HDM216 RXs		
Weight	Transmitter:240g    Receiver:240g		
Dimensions	109.6(L) x 89.5(W) x 26.3(H)mm *2pcs		
Colour	Black		



WEE/CG07835S

This symbol on the products and/or accompanying documents means that used electronic equipment must not be mixed with general household waste. For treatment, recovery and recycling please return this unit to your trade supplier or local designated collection point as defined by your local council.

*All specifications are approximate. Kovert.com reserves the right to change any product specification or features without notice. Whilst every effort is made to ensure that these instructions are complete and accurate, kovert.com cannot be held responsible in any way for any losses, no matter how they arise, from errors or omissions in these instructions, or the performance or non-performance of the camera or other equipment that these instructions refer to.*