

□ MOD100 User Manual □



- View CCTV As Digital TV Channel
- Full 1080p HD
- HDMI & AV Inputs
- Backlit LCD Display

Introduction

Most homes still use co-ax as a way to distribute TV signals from the aerial to the various TVs within the property. The new MOD100 modulator allows you to make the best out of this set up and use it to distribute your home CCTV through this same co-ax network.

It works by allowing the HDMI output of a DVR (or other equipment such as a Satellite box) to be converted into a digital RF signal or "Digital TV channel" so you can distribute it around a home and watch it on any TV just like it was a real digital TV channel.

The MOD100 produces a high quality 1080p picture far superior to an analogue modulated signal and as all new TVs contain a digital tuner it's a great way to distribute CCTV in a home or a commercial building via co-ax.

Because the HDMI input to the MOD100 also carries sound and video, any connected TVs will also be able to playback sound from the DVR or other device too.

The MOD100 is also extremely useful for distributing the output from DVRs to multiple "TVs" in commercial environments such as pubs or clubs as it can all be done over low cost co-ax using an off the shelf RF distributor.

Note: The MOD100 has to process and digitise the HDMI input from the DVR and this creates a small delay or "latency" in its output, this is typically in the region of 200 milliseconds. This means the TV picture would be around 1/5 second behind what the DVR's output is doing. It's very similar to the latency you get with IP cameras systems.

User Information

- The modulator must be installed in a clean, dry environment where it will not be exposed to high temperatures, moisture or excessive dust.
- Do not touch the modulator or any of its connections with wet hands.
- Ensure the power is switched off if the modulator is not in use for a long period of time.
- There are no user serviceable parts in the modulator and opening or attempting to repair the product will void the warranty.
- Only use the PSU originally supplied with the product.
- Do not install or use the device if the power cable is damaged.
- Ensure the power to the modulator is switched off when connecting or removing cables.



Contents & Accessories

Connections & Controls	4
Installation	6
Menu System	8
Trouble Shooting	11
Updating Firmware	12
Other Products To Consider	13
Specification	16

Accessories Included

To make the installation as easy as possible the MOD100 is supplied with the necessary leads for connecting video equipment and a PSU as well.



1.75m HDMI Lead

Braided HDMI lead with gold plated connections. One end of the cable features a clever locking screw for securing it to the modulator which prevents the lead from being removed accidentally.



1.5m Phono Lead

High quality AV lead with gold plated Phono connections for the best signal possible.



Power Supply

So that the modulator is ready to use right out of the box we supply a 12V DC / 2A plug-in PSU with a 2.1mm DC connection.

Connections & Controls

Front Panel

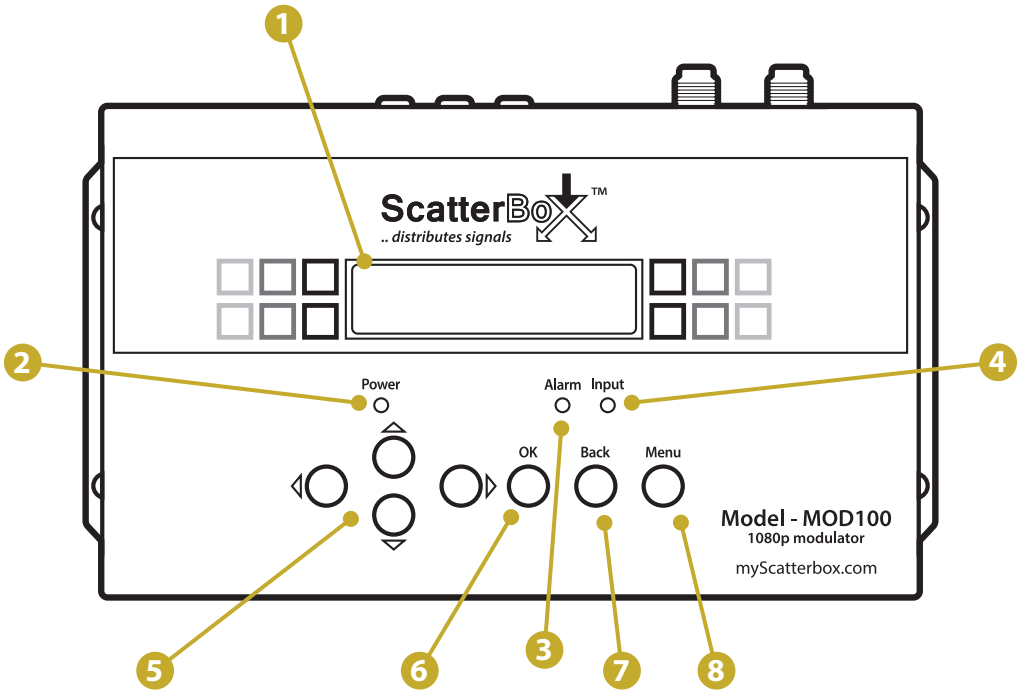

No.	Feature	Function
1	LCD Display	Backlit display shows video information, menu options and parameters. After a few seconds of inactivity the MOD100 will enter power saving mode and the backlight will turn off automatically.
2	Power Indicator LED	Shows when power is being supplied to the MOD100.
3	Alarm Indicator LED	Indicates there has been a loss of video from the input device.
4	Input Indicator LED	Lights up when any input is detected. HDMI or AV.
5	Navigation Buttons	Used to navigate through the menu system and change parameters. (For more information on controlling the menu system see page 8)
6	OK Button	Used to select menu options and confirm changes.
7	Back Button	Press to return to the previous screen.
8	Menu Button	Press to display or exit the menu system. (Press twice when in power saving mode)

Connections & Controls

Connections

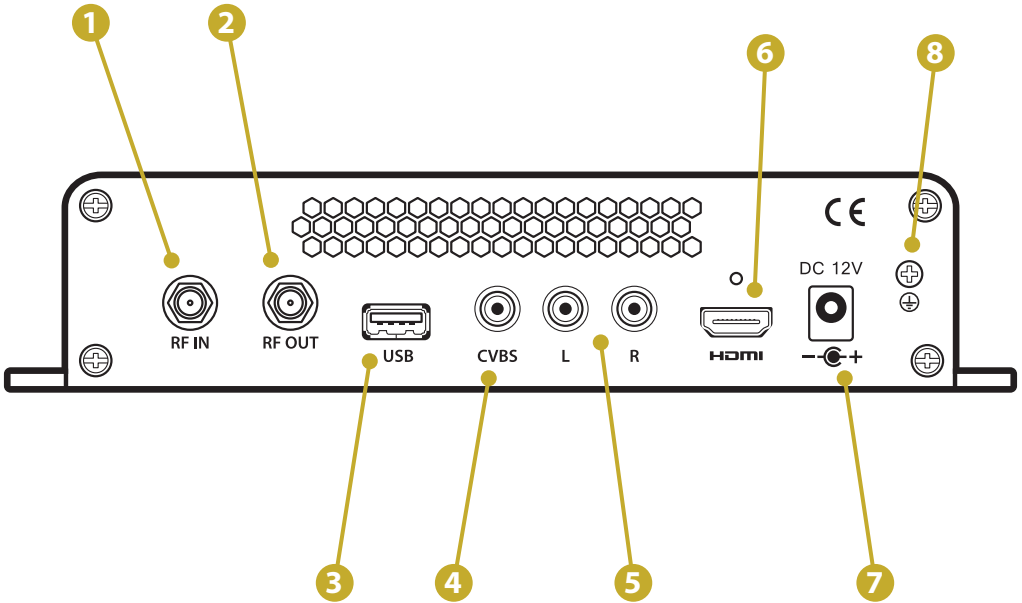

No.	Feature	Function
1	RF Input	F-type socket for connecting TV aerial. (<i>-10dB Signal loss</i>)
2	RF Output	F-type socket used to output the modulated signal.
3	USB Socket	For updating the firmware on the unit. (<i>For more information see page 12</i>)
4	AV Video Input	Phono socket for connecting video (Yellow).
5	AV Audio Input	Phono sockets for connecting stereo audio left (White) and right (Red).
6	HDMI Input	HDMI socket for connecting HD devices. There is a small threaded hole above the HDMI socket for securing the HDMI lead provided (<i>See page 3</i>).
7	Power Socket	2.1mm DC Socket for connecting 12V DC PSUs.
8	Ground	Used to earth the metal case.

Installation - Single Unit

Below is a typical example of how the MOD100 may be installed into a residential property. Although the MOD100 has a built-in combiner you may encounter problems with weaker signals. To achieve the best outcome we recommend that you use an external DC combiner such as the AER190 as they suffer from far less signal loss.

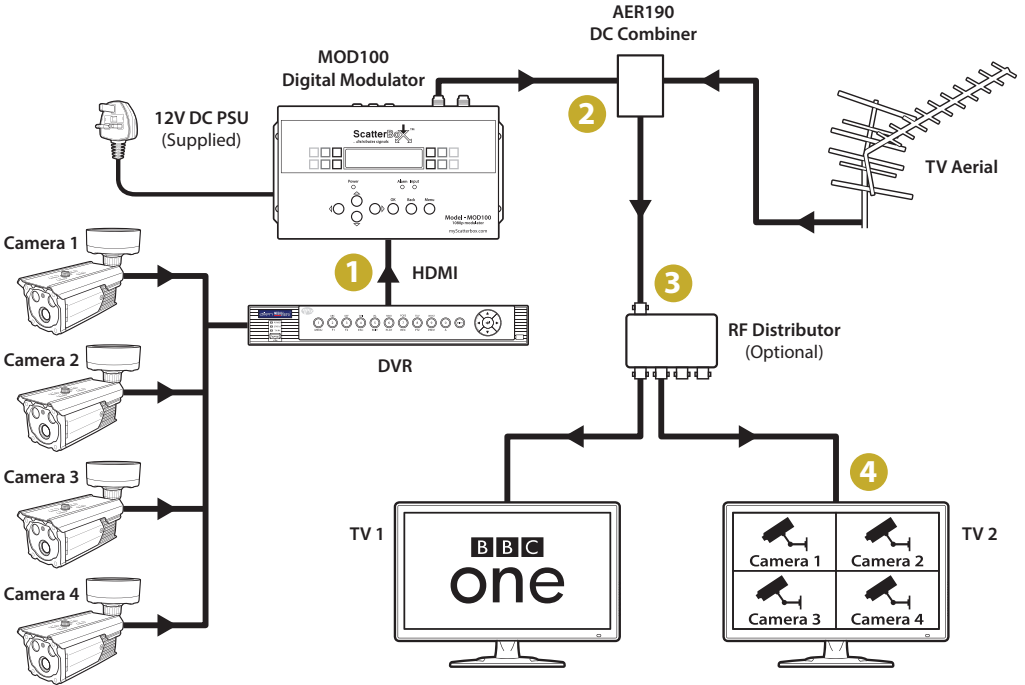

- 1 Connect the DVR (or other video equipment) to the HDMI or AV input of the MOD100.
- 2 Connect both the RF output of the MOD100 and the TV aerial to a DC combiner such as the AER190 (see page 14). This will merge the two signals into one.
- 3 Optional - Use an RF distributor to view the CCTV images on multiple TVs throughout the property.
- 4 Re-tune all TVs to discover and view the CCTV images as a digital TV channel.

Note: Do not turn on the power to the MOD100 until all cables have been connected and the unit has been earthed.

Masthead amplifiers must be installed after the MOD100 as it will block the DC voltage.

Installation - Multiple Units

On larger commercial or retail installs such as bars, shopping centres and hotels you could connect multiple units together to enable a number of devices to be viewed as separate digital TV channels. This could be used to distribute sports channels around a pub or information channels to hotel rooms. **Up to five MOD100s can be connected** using the method shown below.

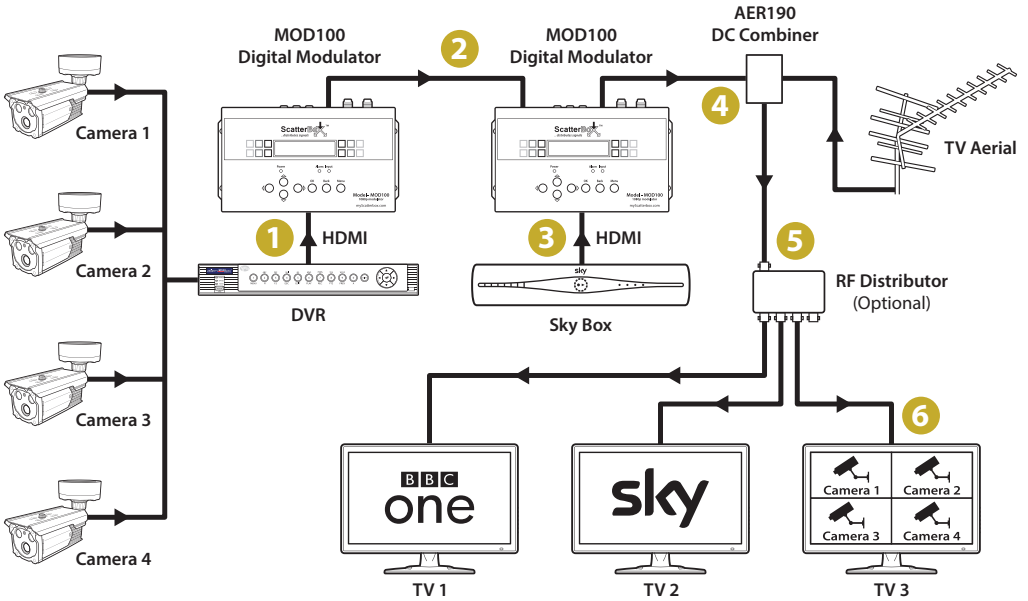

- 1 Connect the DVR (or other video equipment) to the first MOD100.
- 2 Connect the RF output of the first MOD100 to the RF input of the second MOD100.
- 3 Connect the second video source (e.g. Sky box) to the second MOD100.
- 4 Connect the RF output of the second MOD100 and the TV aerial to a DC combiner such as the AER190 (see page 14).
- 5 Optional - Use an RF distributor to view the images on multiple TVs.
- 6 Re-tune all TVs to view both video sources as new digital TV channels.

Note: Do not turn on the power to the MOD100 until all cables have been connected and the unit has been earthed.

Masthead amplifiers must be installed after the MOD100 as it will block the DC voltage.

Menu System

The MOD100 features an easy to use menu system for setting up and managing the unit itself and the new digital TV channels.

Navigating The Menu System

Press the '**Menu**' button to display the main menu. If the unit has entered power saving mode you will have to press the '**Menu**' button twice.

Use the **Up** and **Down** arrow buttons to highlight the submenu you wish to enter or parameter you want to configure.

Press the '**OK**' button to select a submenu or parameter and to confirm selection or changes.

The '**Back**' button returns you to the previous screen. When modifying parameters the '**Back**' button can be used to exit without saving changes.

The **Left** and **Right** arrow buttons are used to switch between given options and to move the cursor during manual input.

Modifying Parameters

There are two ways of changing the parameters on the MOD100. The first is by selecting a value from a pre-defined list and the second is by manual input.

Parameters with an asterisk (*) at the beginning have a pre defined list from which you can choose a value. Press '**OK**' to select the parameter and the asterisk will change to a right arrow (▶). You can then use the **Up** and **Down** arrow buttons to select the value you want and then press '**OK**' to confirm your selection.

Parameters without an asterisk at the beginning can be modified manually. Press '**OK**' and the cursor will start flashing on the first character. Use the **Up** and **Down** arrow buttons to change the value and the **Left** and **Right** arrow buttons to move the cursor. When finished press '**OK**' to confirm your input.

Acronyms

The handy tables below lists the acronyms used in the menu system and what they stand for.

Acronym	Meaning
TSID	Transport Stream ID
ONID	Original Network ID
NIT	Network Information Table
PMT	Program Map Table

Acronym	Meaning
PMT	Program Map Table
PID	Packet Identifier
FEC	Forward Error Correction

Menu System

Note: When connecting directly to the video source such as a DVR, DVD/Blu-Ray player or a Sky box you only need to configure the submenus marked with an asterisk (*). All other submenus can be left as the default value.

Main Menu	Submenu(s)	Parameter	Function
Status	Alarm	Alarm status	States the cause of the alarm
	Uptime	System uptime	Displays the length of time the unit has been up and running. This can be used to see when the unit was last switched off or lost power.
Encoder	Interface*	Auto / HDMI / CVBS	Users can set which input is used, HDMI or CVBS. When set to Auto both inputs can be used but the unit will automatically switch to HDMI when a HDMI input is connected.
	Video in status	Locked / Not lock	Displays 'Locked' when an input is detected and 'Not Lock' when no input is detected.
	Resolution	Input resolution	Shows the resolution of the video source.
	Video bitrate (Mbps)*	1.000 ~ 18.000 (8.000)	Higher bitrates produce better quality images but they can't be transmitted as far.
	Audio bitrate (kbps)*	64 / 94 / 128 / 192 / 256 / 320	Higher bitrates produce better quality audio but it can't be transmitted as far.
Stream	TSID	00000 ~ 65535 (00899)	Choose a specific transport stream from the broadcasting network.
	ONID*	00000 ~ 65535 (00001)	The unique ID of the network who originally broadcast the stream. In the UK this must be set to 09018.
	Network ID	00000 ~ 65535 (00001)	The unique ID of the network who is currently broadcasting the stream e.g. BSkyB
	Network name	Manual entry (network)	Set the name of the network if desired.
	Private data	0x0 ~ 0x99999999 (0x0)	Allows you to specify a private data stream which does not need to be interpreted as video or audio.
	NIT insert	Yes / No	Choose to insert the Network Information Table or not. The NIT describes how the transport streams are organised.
	NIT ver mode	Automatic / Manual	Choose if NIT version is assigned automatically or manually.
	NIT version	0 ~ 99 (0) (Manual only)	Allows users to manually set the NIT version.
	Service name*	Manual entry (AlienDVR)	Set the name for the channel as you want it to appear in the channel list on the TV.
	Provider name	Manual entry (TV-provider)	Gives the option to manually enter the name of the provider. e.g. BBC, BSkyB.
	Program number	00000 ~ 65535 (00100)	Allows users to manually set the Program Number.

Continued on next page ▼

Menu System

Main Menu	Submenu(s)	Parameter	Function	
Stream (Continued)	PMT PID	0 ~ 9999 (0100)	Set the PID number for the PMT. (Must be a different to video and audio PID)	
	Video PID	0 ~ 9999 (0101)	Set the PID number for the video stream. (Must be a different to PMT and audio PID)	
	Audio PID	0 ~ 9999 (0102)	Set the PID number for the audio stream. (Must be a different to PMT and video PID)	
Modulator	Country	UK	UK by default. Can not be changed.	
	Channel*	21 ~ 60 (60)	Set which channel band the modulator signal is transmitted over.	
	Bitrate	Current / Max	Used to see the current and maximum possible modulating bitrate.	
	Advanced config*	RF frequency* (MHz)	142.5 ~ 946 (786.0)	Must be set to the same frequency as the channel band.
		Bandwidth (M)*	6 ~ 8 (8)	Set the bandwidth of the modulated signal. Must be set to 8M for use with DVB tuners.
		Constellation*	64 QAM / QPSK / 16 QAM	Set the modulation scheme used. Must be set to 64 QAM for use with DVB tuners.
		FEC*	1/2 / 3/4 / 5/6 / 7/8	Set the code rate for useful information vs total information sent. The higher the code rate the stronger the signal.
		FFT*	2K / 8K	Must be set to 8K for use with DVB tuners.
		Guard interval*	1/4 / 1/8 / 1/16 / 1/32	The Guard Interval is the amount of time between distinct transmissions so they do not interfere with each other through echoes, reflections etc. 1/32 offers the lowest protection but the highest data rate. 1/4 offers the highest protection but the lowest data rate.
	RF level (dBm)*	-14 ~ +6 (0)	Control the gain to counter the effects of transmission distance and other equipment.	
System	Save config	Yes / No	Save a current working system configuration as a backup if ever needed in the future.	
	Load saved CFG	Yes / No	Load the previously saved system configuration if problems occur.	
	Factory reset	Yes / No	Reset the unit to its default settings.	
	LCD time-out	5 / 10 / 30 / 45 / 60 / 90 / 120	Set the amount of time the backlight is on and the screen is active.	
	Key password	Manual entry (000000)	Set a password to prevent unauthorised access to the menu system.	
	Lock keyboard	Yes / No	Enable/disable the password. The password is automatically disabled every time it is entered.	
	Product ID	Serial Number	View the units unique serial number.	
	Version	Firmware Version	View the current firmware version.	

Trouble Shooting

The table below describes common problems you may encounter when using the MOD100 along with the most common solutions for rectifying the problem.

Problem	Possible Cause	Solution
Modulator not appearing as a digital TV channel	Channel Number	The MOD100 should automatically appear as channel 800.
	Signal Loss	The gain is too low due to transmission distance or interference from equipment. Increase the RF Level in the Modulator menu under Advanced Config. We also recommend using an external DC combiner rather than the one built-in as they suffer from far less signal loss.
	MPEG-2 Code rate too low	The code rate is defined by a combination of the Bandwidth, Constellation, FEC and Guard Interval. When using DVB equipment the code rate must be at least 22MHz. Check the Code Rate table on page 12 to see if the current combination produces a signal of at least 22MHz.
	RF Frequency	The RF Frequency of the modulator must be the same as the frequency of the assigned channel band. e.g. Channel 60 = 786.0MHz. When selecting a channel band the frequency for the band is also displayed and the modulator's RF frequency must match this.
	Incorrect ONID	In the UK the ONID must be set to 09018. This can be set in the Stream menu.
Modulator appearing as a digital TV channel but no image displayed	Resolution from input device not supported by TV	The MOD100 outputs the same resolution as it receives. For example, if the resolution from the original input device is 1080p the MOD100 will output a 1080p signal. If the TV only supports a maximum of 720p the new channel will still be discovered but no image will be displayed. In this case you will need to change the resolution of the input device to one which the TV supports.
No or poor signal when using a masthead amplifier	RF Level too high	If the RF Level is too high when it is amplified the TV is swamped and can not produce an image. Reduce the RF Level in the Modulator menu under Advanced Config. This is a trial and error process so you may have to try various RF levels checking the result each time.
	Amplifier installed before modulator	The MOD100 does not support AC/DC pass through so the voltage is blocked out. When using a masthead amplifier it must be installed after the MOD100.
Lose Freeview channels when modulator is switched on	Attenuation	The built-in combiner produces -10dB attenuation which can be too much when you have a weak TV signal. We recommend that you always use an external DC combiner to merge the MOD100's RF output and your TV aerial as shown on page 6.
'Unknown' displayed on LCD screen	Loose connections	Check the connections to both the MOD100 and signal source are correct and secure.
	Faulty cable	Try a different cable or test the cable used with other equipment to make sure it isn't damaged or faulty.
	Resolution not supported	The resolution of the signal from the input device may not be supported by the MOD100. Supported resolutions are listed in the specifications on the rear cover.

Continued on next page ▼

Trouble Shooting & Updating Firmware

MPEG-2 Code Rates

The table below shows the code rates produced by different combinations of the constellation, FEC, Bandwidth and Guard Interval. DVB equipment requires a code rate of at least 22MHz:

Modulation Constellation	FEC	6MHz Bandwidth				7MHz Bandwidth				8MHz Bandwidth			
		Guard Interval				Guard Interval				Guard Interval			
		1/4	1/8	1/16	1/32	1/4	1/8	1/16	1/32	1/4	1/8	1/16	1/32
QPSK	1/2	-	-	-	-	-	-	-	-	-	-	-	6.03
	2/3	-	-	-	6.03	5.80	6.45	6.83	7.03	6.64	7.37	7.81	8.04
	3/4	-	6.22	6.58	6.78	6.53	7.25	7.68	7.91	7.46	8.29	8.78	9.05
	5/6	6.22	6.91	7.31	7.54	7.25	8.06	8.53	8.79	8.29	9.22	9.76	10.05
	7/8	6.53	7.25	7.68	7.91	7.62	8.46	8.96	9.23	8.71	9.68	10.25	10.56
16 QAM	1/2	7.46	8.29	8.78	9.04	8.70	9.67	10.24	10.55	9.95	11.06	11.71	12.06
	2/3	9.95	11.05	11.70	12.06	11.61	12.90	13.66	14.07	13.27	14.75	15.61	16.09
	3/4	11.19	12.44	13.17	13.57	13.06	14.51	15.36	15.83	14.93	16.59	17.56	18.10
	5/6	12.44	13.82	14.63	15.08	14.51	16.12	17.07	17.59	16.59	18.43	19.52	20.11
	7/8	13.06	14.51	15.36	15.83	15.24	16.93	17.93	18.47	17.42	19.35	20.49	21.11
64 QAM	1/2	11.19	12.44	13.17	13.57	13.06	14.51	15.36	15.83	14.93	16.59	17.56	18.10
	2/3	14.92	16.58	17.56	18.09	17.41	19.35	20.49	21.11	19.91	22.12	23.42	24.13
	3/4	16.79	18.66	19.76	20.35	19.59	21.77	23.05	23.75	22.39	24.88	26.35	27.14
	5/6	18.66	20.73	21.95	22.62	21.77	24.19	25.61	26.39	24.88	27.65	29.27	30.16
	7/8	19.59	21.77	23.05	23.75	22.86	25.40	26.89	27.71	26.13	29.03	30.74	31.67

Updating Firmware

Over time we may release new firmware when adding new features or changes are made in broadcasting standards. Installing the new firmware is a quick and easy process just follow the steps below:

1. Copy the IMG file on to a USB flash drive.

Note: The IMG file must be copied straight on to the flash drive and not inside a folder.

2. Disconnect the power from the MOD100 and insert the USB flash drive into the USB socket on the top of the unit.
3. Reconnect the power and when the LCD display reads DVB-T the upgrade is complete.
4. Once complete disconnect the power from the MOD100 and remove the USB flash drive.
5. Reconnect the power and then in the menu navigate to 'Factory Reset' and select 'Yes'. Exit the menu system and when prompted to 'Save Config' select 'Yes'.

Other Products To Consider



A Quality High End HD-TVI, Analogue & IP DVR



Order Code: MAX416

maximum Quality • 1080P Realtime Recording 16Ch •

maximum Features • 16 Audio Outputs & Alarm Inputs •

maximum Storage • Up to 48TB - 8HDD + eSATA drives •



Mix & Match Technology
Compatible with HD-TVI, analogue & IP



1080p @ 25fps
Realtime recording on every channel



Up To 48TB! (8 HDD)
Install up to 8 6TB hard drives



16 Channel Audio
Audio on every channel



16Ch Full Alarm Inputs
Use up to 16 alarm inputs per channel



AlienDDNS
Free DDNS so no costly third party



Free Remote Setup
The DVR can be setup remotely for free!

Designed to be the best DVR we have ever produced, the MaxPix+ has it all.

Hybrid technology means the MaxPix+ can record HD-TVI, analogue and IP cameras simultaneously. This offers great flexibility allowing the MaxPix+ to be used on new installs or HD upgrades.

The MaxPix+ is packed full of features making it one of the most powerful DVRs on the market. It's has dual LAN for faster network performance and added security. It can record 1080p HD images at 25fps on all 16 channels at the same time. There's audio on every channel, alarm inputs on every channel and built-in up the co-ax camera control.

Visit alienDVR.com

Other Products To Consider

RG59 Co-ax Cable

antihum.com

Glued foil sheath provides maximum protection against interference and prevents "loose" foil shorting to the centre pin

0.12 x 48 aluminium wire shield

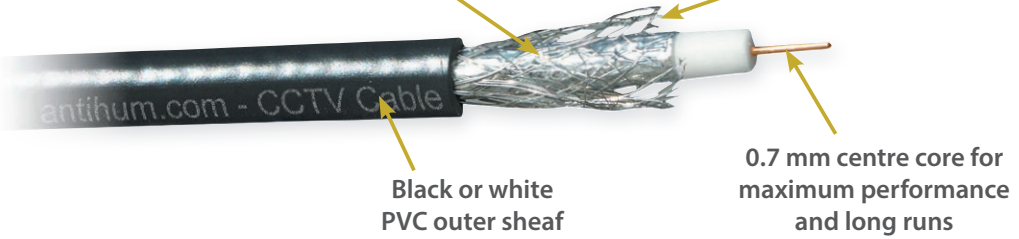

Order Codes:

100m Black: **CAB080**

100m White: **CAB090**

250m Black: **CAB072**

250m White: **CAB095**

High quality AntiHum branded RG59 co-ax cable can be used for both CCTV and TV systems. Available in black and white to suit any installation in lengths of either 100 or 250m.

DC Combiner

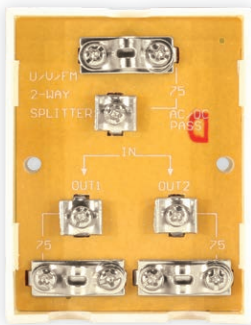

A highly recommended piece of kit when installing a modulator. The DC combiner merges the modulator's output with signal for the TV aerial. This is the most efficient way of integrating a modulator into a household TV system.

Order Code: **AER190**

F-Type Connectors & Leads

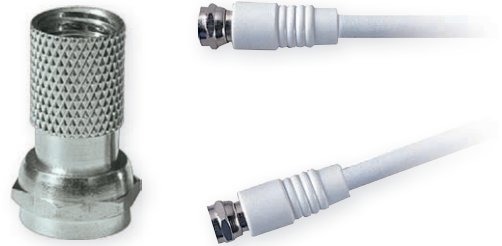

F Plugs are essential for connecting to and from the MOD100. The ready made leads are ideal for when connecting multiple units together.

Order Codes:

Connectors (Pack Of 10): **AER207**

Connectors (Pack Of 100): **AER206**

1m F Plug - F Plug Lead: **VID112**

5m F Plug - F Plug Lead: **VID115**

Other Products To Consider

Aerial Connectors

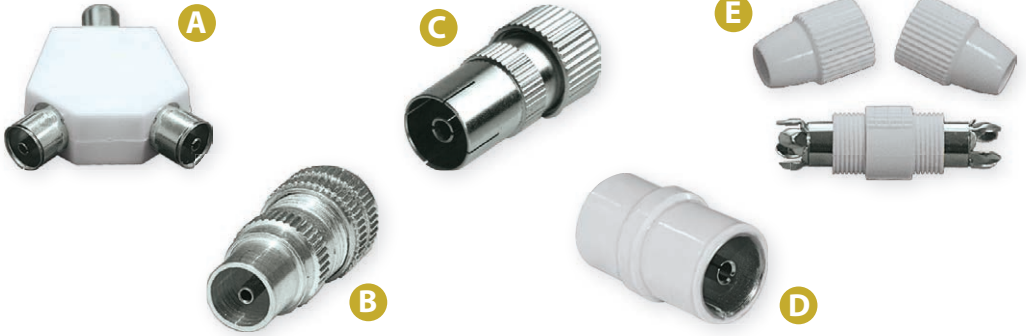

When adding to or installing a new TV system the right aerial connectors are a must have. Connectors for terminating cables, joining cables and splitting signals will all come in handy.

Order Codes:

- A. Co-ax Y Splitter: **AER200**
- B. Co-ax Plug (Pack Of 10): **AER202**
- C. Co-ax Socket (Pack Of 10): **AER203**
- D. Co-ax Coupler (Pack Of 10): **AER209**
- E. Co-ax Joiner (Pack Of 10): **AER204**

HDMI Adapters

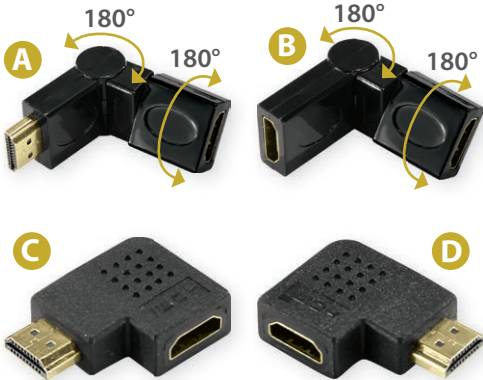

Order Codes:

- A. Plug - Socket Adapter: **VID500**
- B. Plug - Socket Adapter: **VID511**
- C. Plug - Socket Adapter (Left): **VID512**
- D. Plug - Socket Adapter (Right): **VID513**

HDMI Leads



A must have when installing modern video equipment. It's can also be a good idea to carry a few spares just in case.

Order Codes:

- 1m HDMI - HDMI Lead: **VID501**
- 2m HDMI - HDMI Lead: **VID502**
- 3m HDMI - HDMI Lead: **VID503**
- 5m HDMI - HDMI Lead: **VID505**
- 10m HDMI - HDMI Lead: **VID510**

Specification

Feature	Function	Specification				
Video	Connection	HDMI		CVBS		
	Encoding	H.264 MP@L 3.0 / 3.1 / 4.0		H.264 MP@L 3.0		
	Interface	HDMI*1		CVBS*1 (RCA)		
	Resolution	Input	Output	Input	Output	
		480@59.94 / 60p	480@60p	480@60p	480@60p	
		480@59.94/60i	480@30p	480@60i	480@30p	
		576@50i	576@25p	576@50p	576@50p	
		720@50 / 59.94 / 60p	720@50 / 59.94 / 60p	576@50i	576@25p	
		1080@50i	1080@25p			
	1080@59.94 / 60i	1080@30p				
1080@59.94 / 60p	1080@30p					
Aspect Ratio	16:9 / 4:3		4:3			
Bit Rate	1.000 ~ 18.000 Mbps					
Audio	Encoding	MPEG Layer 2				
	Interface	Stereo (HDMI)		Analogue Stereo / Mono (RCA Unbalanced)		
	Sample Rate	48KHz				
	Bit Rate	64 / 96 / 128 / 192 / 256 / 320kbps				
Modulation	Standard	DVB-T COFDM				
	Bandwidth	6M / 7M / 8M				
	Scheme	QPSK / 16QAM / 64QAM				
	Code Rate	1/2 / 2/3 / 3/4 / 5/6 / 7/8				
	Guard Interval	1/4 / 1/8 / 1/16 / 1/32				
	Transmission	2K / 8K				
	MER	≥31 dB				
	RF Frequency	142.5 ~ 946 MHz				
	RF Level	-14 ~ +6dB				
General	Attenuation	10dB				
	Configuration	Backlit LCD Display / Push Button Controls				
	Language	English				
	Firmware	Upgradable Via USB				
	Power Supply	12V DC 2A Plug-in (Supplied)				
	Weight	1kg				
	Dimensions	203 x 120 x 52mm				

All specifications are approximate. We reserve the right to change any product specifications or features without notice. Whilst every effort is made to ensure that these instructions are complete and accurate, We cannot be held responsible in any way for any losses, no matter how they arise, from errors or omissions in these instructions, or the performance or non-performance of the equipment that these instructions refer to.



WEE/CG07835S

This symbol on the products and/or accompanying documents means that used electronic equipment must not be mixed with general household waste. For treatment, recovery and recycling please return this unit to your trade supplier or local designated collection point as defined by your local council.