

the excelPTZ range

Installation and Operation Manual

Budget PT Colour Dome 12vDC

Models covered
PTZ205



Version 1

For updates to these instructions visit www.excelPTZ.com

CONTENTS TABLE

Description	Page No.
Contents	2
Safety Precautions	3
Key Functions	4
Getting the dome up & running	5
Overview – introduction to fitting PTZ equipment	5
RS485 Wiring methods & Tips	7
Overcoming RS485 data loss using an RS485 distributor	10
Setting up the Dome Camera	12
Powering the domes	13
RS485 connection – Connecting the Keypad or DVR to the Dome	14
Connecting the video out of the dome	15
Setting the PTZ dip switches	17
Setting up a unique address in a dome	18
Setup of the Protocol and the Default Baud Rate	19
Using the CCT786 and CCT768 keypad with the excelPTZ series	21
Presets and other functions	22
Auto Scan – How to set it up	23
Patrols/Tours – How to set them up and use them	23
Installation Instructions	25
Technical Specifications	31

Please read this operation manual carefully
before installing and using this unit !!!!



Please read the following;

1. Please read the operation manual carefully before installing and operating the product.
2. The actual dome requires a **12v DC** power supply with a minimum rating of **1.2Amps**. The rated input voltage of the camera is also 12v. This gets its power from the dome and does not require a separate PSU. **Do not connect 24V AC to the dome under any circumstances!!**
3. During the course of transportation, storage and installation, the product should be handled with care avoiding vibration and any weight pressure, which may cause damage to the sophisticated optical and electronic equipment inside the machine.
4. Do not attempt to disassemble the camera. In order to prevent electric shock, do not remove screws or covers. There are no user-serviceable parts inside the camera.
5. Always use and adhere to current electrical safety standards to install and use the dome. Use a correctly rated power supply. The RS-485 and video signal cables should be kept way from other high voltage equipment such as mains cables and especially fluorescent lights. Using an anti surge protection device is recommended to prevent damage to the domes from lightning and mains surges. Damage to domes by lightning or mains voltage surges is not covered under the dome's warranty.
6. Do not operate in areas exceeding the stipulated limitations concerning temperature, humidity and power supply.
7. Do not aim the camera directly towards the sun or an extreme light source whether it is switched on or not. Do not let the camera focus on bright and stationery objects for a long time. Doing either of these may damage the camera.
8. Do not use strong detergents to clean the main body of the camera as these may damage the dome cover or paintwork. Wipe dirt with dry cloth. If needed a *mild* detergent can be used.
9. Operate the dome camera with great care to avoid shock or vibration. If operated incorrectly, the Dome could be damaged.
10. Ensure the dome is not dropped. Never mount the unit on a ceiling that cannot support its weight.
11. If necessary, use a commercial lens cleaning paper to clear the lens windows. Gently wipe the lens window until clean.

NOTE –

This is a 12v D.C camera !!

Applying any other voltage to it
will damage the unit and void the
warranty.

KEY FUNCTIONS

The excelPTZ dome range –

Budget Range

A basic PT dome camera for budget applications, which incorporates a standard 3.6mm colour camera. The dome case is made out of metal for a robust attractive appearance. It has a multifunctional decoder and an on-board processor for logic handling. The dome is easy to connect, install, maintain and operate. The dome is compact with a modern and appealing appearance.

The dome fits directly to a ceiling or overhead surface, but can also be mounted on a wall using the wall mount bracket. The base is of metal construction and the dome is for indoor use only.

This is the most basic of the Budget series and only has a Pan and Tilt mechanism with a standard 3.6mm lens with no zoom facility. It does not have the capabilities of the advanced functions of the 500 and 600 series but does allow up to 32 preset positions and a tour option.

Description of Functions

1. Integrated Multi-Protocol Decoder

The integrated multifunctional decoder can communicate with 5 different protocols. The baud rate can be independently set allowing compatibility with systems with selectable baud rates from 2400 bps to 19200 bps.

2. Dip Switches

Dip switches control the selection of the protocol, baud rate and camera addresses making this dome camera easy to set up and use.

3. RS485 Interface

This dome uses RS485 serial control and can address from 1 to 1023 cameras using binary addresses.

4. Rotation Range, Speeds and Limitations

The dome can turn 0-360° horizontally and 0-90° vertically at a speed of 0 -12° per second.

5. Scan Facilities

The dome can Auto Scan between two positions with a dwell time of 4 seconds at each position and a scan speed of 7.5° per second. The scan can be initiated by using a keypad.

6. Presets

The dome can store up to 32 presets and is capable of running a tour/patrol utilising a maximum of 16 presets. All presets are stored in the dome's non-volatile memory and retained during power loss.

Getting the dome up and running!



You **MUST** connect up the dome and your control equipment on a workbench or kitchen table before the actual site installation and **CHECK YOU KNOW HOW TO INSTALL IT CORRECTLY!!!!!!!!!!!!!!!!!!!!!!**.

By doing this you can set-up any DIP switches, adjust the camera, and learn about how it operates before taking it to site. This will save you hours of time on-site trying to work out why a particular item doesn't function as you expected it to. There is nothing worse than installing something and then having to take it down to see how to get it working!! Do the learning curve in the comfort of your own premises!!!!

Do you KNOW how to install PTZ equipment that is controlled by RS485 data signals?

If not please read the following introduction to PTZ >>>....

Overview- introduction to fitting PTZ equipment

Generally speaking, PTZ Domes requires four things;

- 1- They require a power supply and a cable to supply this power to the dome. Often, domes are 24V A.C but some mini pan and tilt domes such as this model, are 12V DC.
- 2- They require a cable to get the video signal back to the monitor or recording device.
- 3- They require a cable to transmit the "RS485 control signal" from the keypad or DVR to tell the dome to pan and tilt etc.
- 4- They require something to control them, either a keypad or a DVR.

The following diagram indicates the basic cable requirements for a PTZ system.

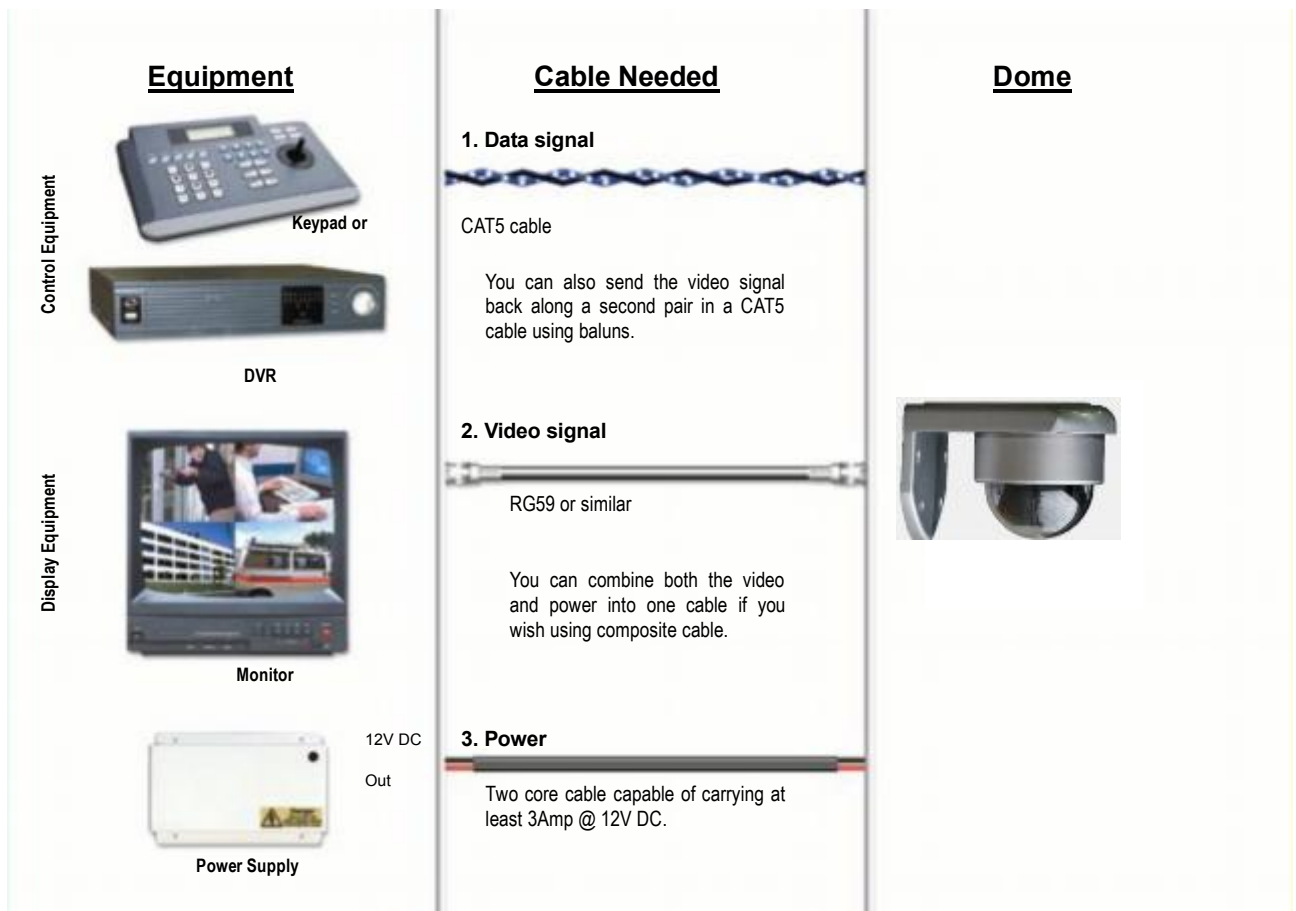

You can get “composite” cables that will carry both the power and the video signals and this has the benefit of combining two of the three cables into one. You may choose to power the dome locally to it, so you may only need to get the video signal back from the dome and the RS485 control signals to it. If this is the case you may choose to use a pair of BALUNS. By using baluns you can send the video signal and control signal down the same CAT5 cable just using different cores for each signal.

The control signal (RS485) is nearly always sent along a “twisted-pair” type cable. The twists in the cable help prevent interference affecting the data signal by “shielding” it. Many installation companies use a CAT5 type or similar cable to run out to the domes to carry the data signal.

If you are considering using baluns please note - DVR’s tend to require very good video signals to function correctly and “passive baluns” can loose some signal strength over the 50 metre mark so try to restrict the use of passive baluns to below 50 metre cable runs when using them with DVRs. Above this distance perhaps consider an active balun. Active baluns require power, passive baluns do not.

You can mix and match how you wire up your PTZ installation and the following general diagram gives you a guideline about how to do it. Remember this is a GUIDE and is not an instruction what to fit!

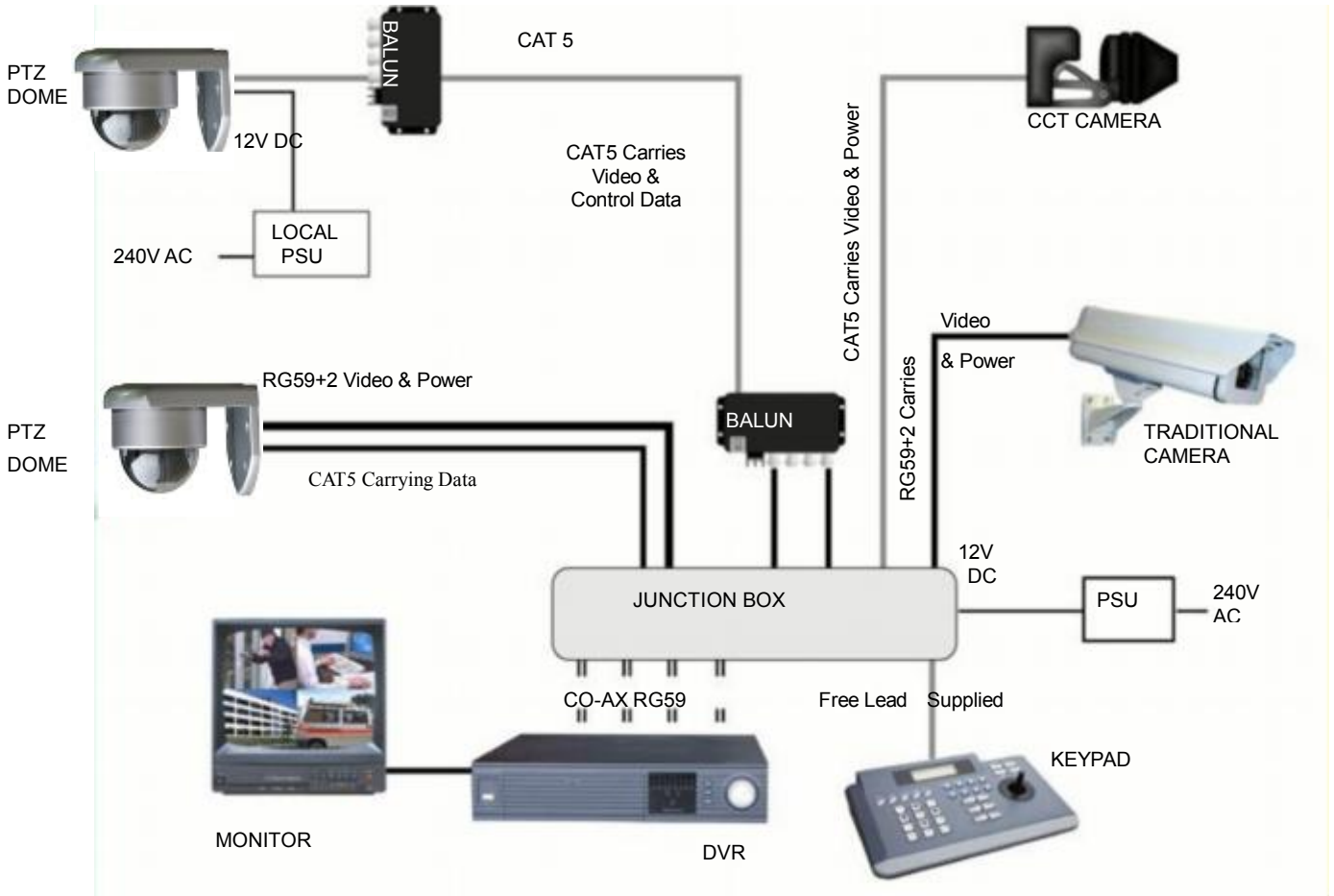

Many installation companies can get the power and video signal correct, but struggle with the control of the dome using the keypad or DVR using the RS485 data.

The key to successfully installing the data cabling to the dome is to get the basics right. Use a quality data cable such as CAT5 (never use just a standard untwisted cable such as alarm cable for the RS485 signal).

Also, you must follow the RS485 wiring convention; the following section explains this;

RS485 Wiring methods & Tips >>>>>

1. Characteristics of RS485

As specified by RS485 standards, RS485 is a half-duplex data transmission type with characteristic impedance of 120Ω . The maximum load capacity is 32 units (domes, keyboards and DVRs).

2. Transmission distances of RS485 Signals using CAT5 or similar cables

Selecting a CAT5 or similar sized twisted pair data transmission cable, the maximum theoretical transmitting distances are as follows:

Baud Rate	<u>Maximum</u> Transmitting Distance
2400 Bps (PELCO-D)	1500m
4800 bps	1000m
9600 bps	600m

PLEASE NOTE - Using inferior cables, or installing the dome in an environment with strong electromagnetic interference, or connecting a lot of PTZ domes to the same cable carrying the RS485 signal will reduce the maximum transmitting distance.

3. RS485 Connection methods

METHOD 1 – DAISY CHAIN CONNECTION.

The general RS485 standard recommends a “daisy chain” connection of equipment that is to be controlled. This means that the control cable is looped out of the one dome to the next dome and so on. The last dome in the line is then fitted with what is known as a “termination resistor”. This has a value of 120Ω .

The resistor is built in the PTZ200 domes and is activated by setting a jumper switch JP1 to ON. The keyboard itself generally has a built-in 120Ω resistor. These termination resistors help make the signal more stable and give the system better reliability so that the domes function as expected. A common mistake installer’s make is not making sure the 120Ω resistor is switched ON in the LAST dome. Also installers often select the resistor to ON in another dome in the chain, these errors will make control of the dome unpredictable.

A simplified Daisy chain is shown below;

This first diagram shows the cables looping in one dome and out of another;

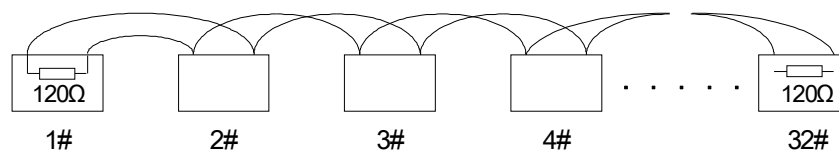

Standard Daisy-Chain connection for the RS485 PTZ control signal

(Just the last dome only has the 120Ω resistor set to on, the first device is the keyboard and has the 120Ω built in as default)

This next diagram is a slight variation on the Daisy Chain arrangement. Again it’s one cable going out to all the domes but instead of the cable going into each dome then back out to the next one, a junction box is used to “Spur-Off” to each dome. Whilst this can be done THE SPUR LENGTH (D) must be NO MORE THAN 7 metres!!!!!!!!!!!!!! The overall cable length between the Controller and the last dome is limited to around 300 meters in such an arrangement.

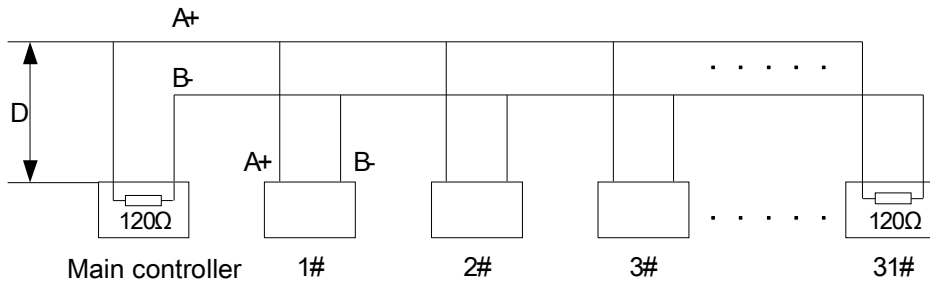

Daisy-Chain connection WITH SHORT SPURS for the RS485 PTZ control signal
 (one main radial with very short spurs to each dome off it, keeping the spurs to less than 7 meters)

TIP - The connection of a 120Ω termination resistor: JP1 is the 120 Ω termination jumper found in the dome head. When the jumper is set between positions 1 and 2 (i.e. between top and middle) the resistor is connected and when the jumper is set between positions 2 and 3 the resistor is not connected.

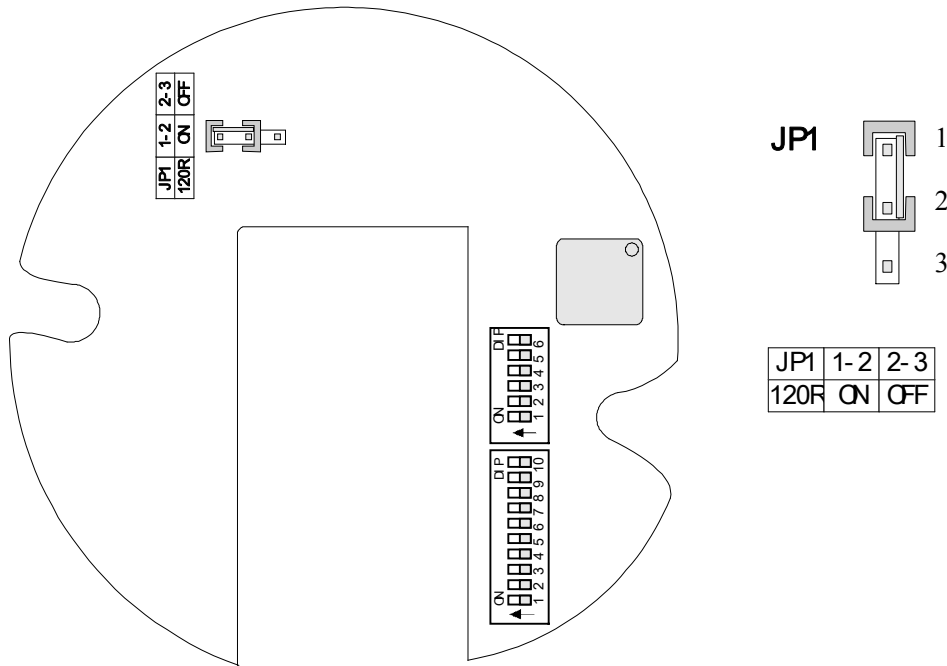

STAR method of connection.

In some circumstances you may need to adopt a star configuration for practical purposes. For instance, all the domes may be so scattered on a large site that running out separate spurs to each dome in a “STAR” array is the only practical solution.

So how do you do this in practice?

The termination resistors must be connected to the two domes that are farthest away from each other, such as domes 3 and 5 in the following “Star diagram”. Note that all the other domes do not have the 120ohm resistor connected. The resistors are already fitted in the domes but are not in circuit. To put them in circuit you must move the JP1 jumper between positions 1 and 2 as previously indicated.

As the star configuration is not in conformity with the requirements of RS485 standards, problems such as signal reflections may arise, especially when there are long cable connections. The results are that control signals are decreased and the dome may not respond to, or just responds intermittently to the controller.

If your STAR circuit is not too extensive with each spur in the region of 20-50 metres you can expect quite good reliable performance using this technique. If you experience any problems though, there is a RS485 distribution box available CODE PT750 to help overcome any problems.

The Star circuit for wiring PTZ's.

The two furthest domes need the 120ohm resistors enabling, by setting the jumper. In this example it's domes 3 & 5.

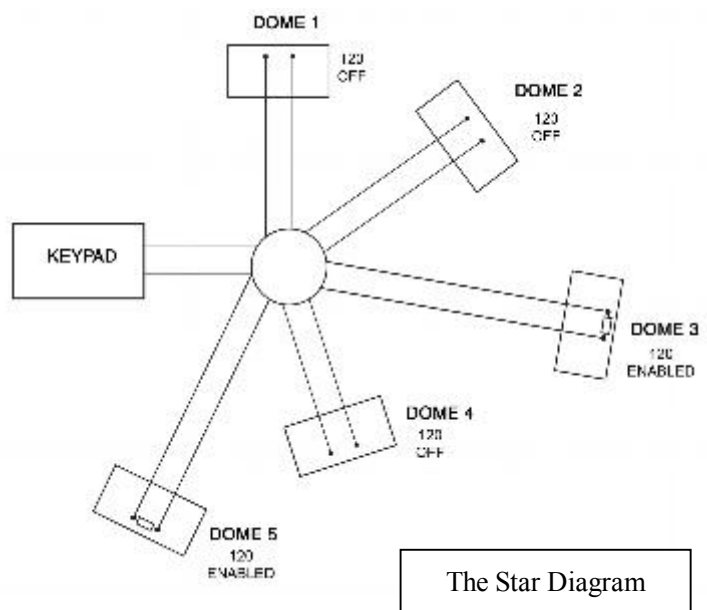

Overcoming RS485 data loss using an RS485 distributor

In the real world not everything always works exactly as it's expected to!

RS485 data signals that control the dome's movements are tiny signals that can get corrupted for many reasons. Poor cable quality, not using a PAIR of cores from a CAT5 but using one core from TWO separate pairs, running the CAT5 cable near mains equipment such as florescent lighting all will have a detrimental effect on the signal. These are things that you can correct with good installation practices.

Where you wish to run several separate CAT5 cables out to send the RS485 data signal out to the domes you are in effect correcting the STAR method of RS485 data distribution. As previously mentioned the problem with the Star method is that it is not actually designed for RS485 but generally works okay if you follow the previous notes on getting the 120ohm resistor setting right, as per the previous notes.

One way that takes the guesswork out of installing the Star method is to utilise an RS485 distributor. This has the advantage that the RS485 signal is correctly distributed to the domes so that they behave as expected.

You can create up to 4 spurs to the domes and put up to 4 domes on each spur. Just like the Daisy chain method the end dome on each spur needs to have the 120ohm resistor enabled.

Although the RS485 distributor is a small additional expense, it takes some of the guess work out of the installation design and gives a more flexible approach to cabling which itself can save time and money on the installation. Not forgetting you get more predictable results!

The RS485 distributor (PTZ750) amplifies the RS485 control signal and distributes it evenly to 4 separate spurs, each spur can have up to 4 domes. This means that you could theoretically have up to 4 individual spurs of over 1000mtrs each to control up to 16 PTZ domes in total.

Ideally you would put just one dome on each spur from the PTZ750 but up to 4 domes is generally acceptable. The following diagram shows a typical use of the PTZ750 RS485 distributor.

In the following example and diagram, domes 1,4,5 and 7 are at the end of each spur and therefore require the 120ohm resistor enabling by moving the JP1 jumper across positions 1 and 2 in each dome. Domes 2,3 and 6 are all “midway” in each spur and do not need the 120ohm resistor and the JP1 jumper needs to be across positions 2 and 3. The PTZ750 itself has four 120ohm resistors built in as shown and you do not have to do anything with the PTZ750 as the resistors are permanently connected within it.

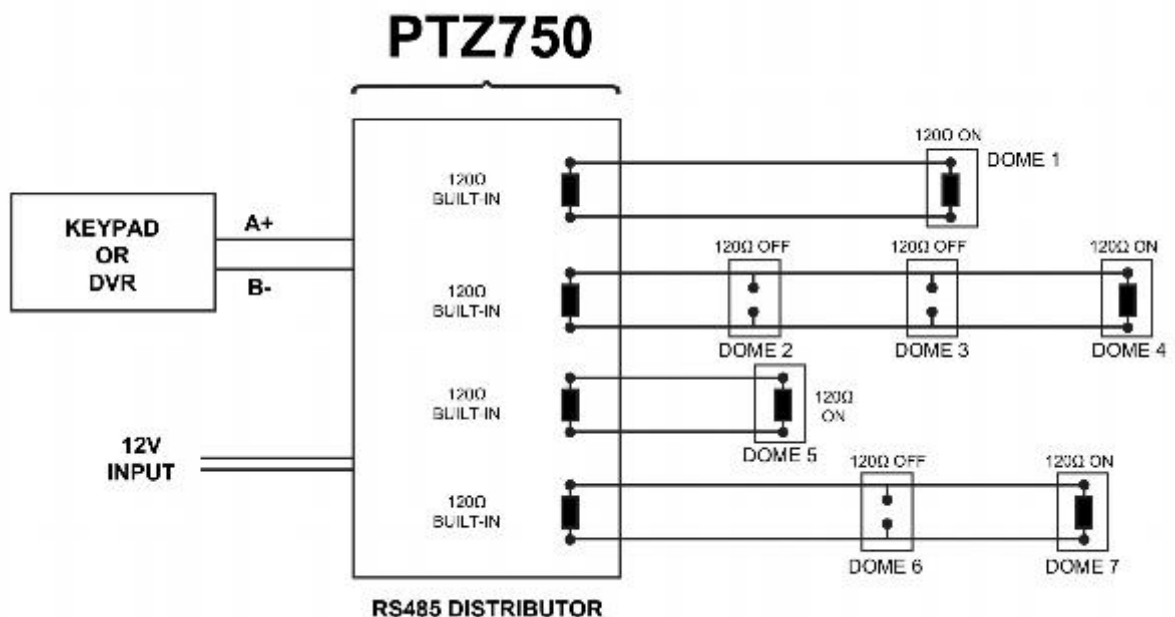

(Diagram showing how to use an RS485 distributor to improve PTZ control reliability)

Please note if you have the PTZ750 located within 5mtrs of the keypad or DVR you can connect up to 3 of them in parallel.

Setting up the Dome Camera

Connection of the System

There are many ways to wire up a PTZ system.

If you have read the introduction at the beginning of these instructions you should have got a good idea what your options are.

Below is a general schematic diagram showing you some of these options.

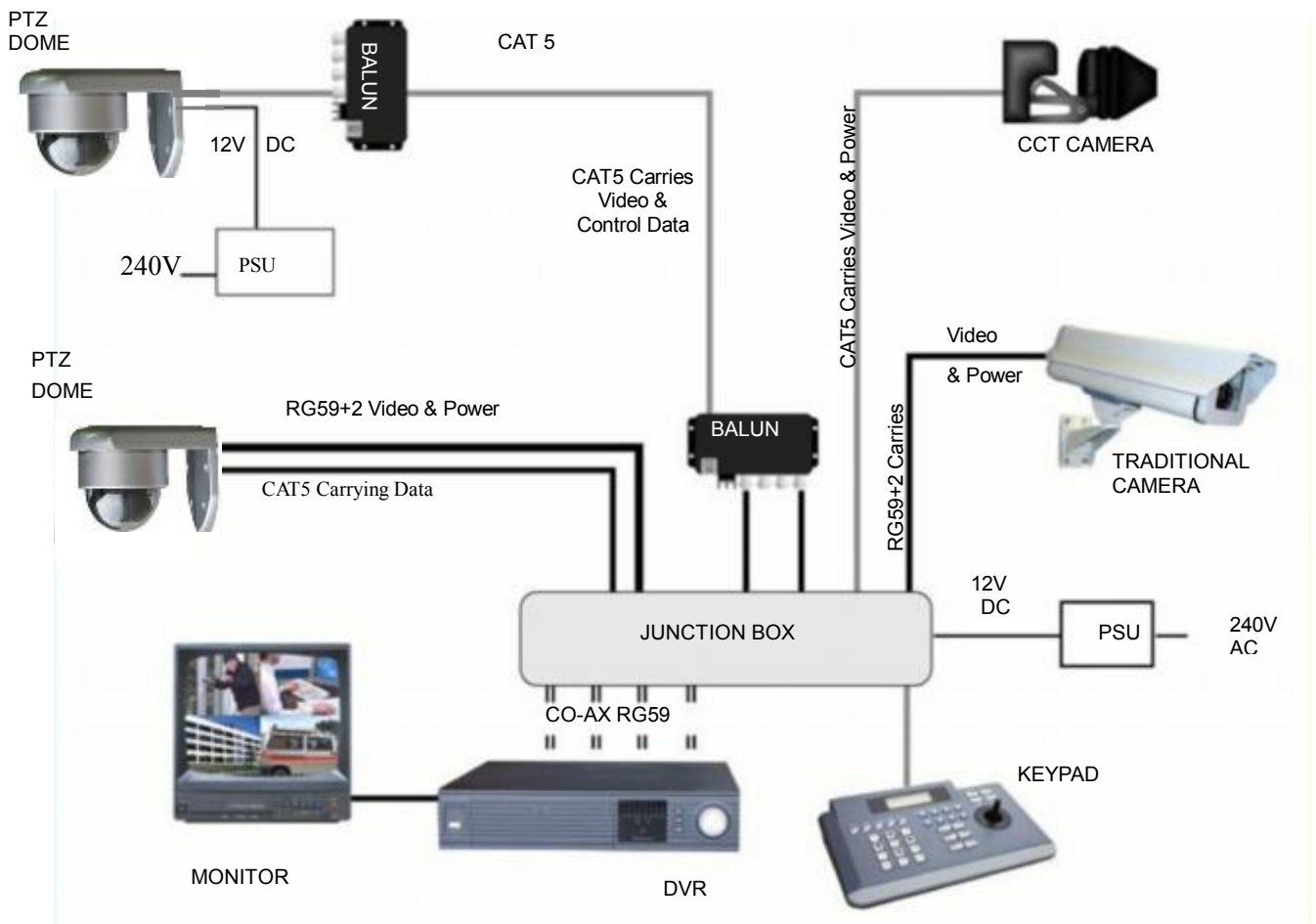

Powering the domes-

All the domes will need power. For this dome it is a 12V D.C power supply. The power supply must be capable of delivering at least 1A per dome, which allows the power supply some spare capacity so that it is not running continually hot.

You can either power each dome with its own PSU locally to it or have the PSU's remotely situated perhaps near the keyboard or DVR. This dome draws approximately 400mA with a camera fitted so you must take this into consideration when working out maximum cable runs.

A popular way to power the domes is using our COMPOSITE VIDEO cable (or shotgun as its also known) as this cable can carry the power to the dome and the video signal back to the monitor or DVR.



The power connection



The power cable coming out of the dome has a 2.1mm mini jack socket connected. Connect a suitable 12V D.C power supply with a mini jack plug.

The BNC connector is the “VIDEO-OUT” from the camera and goes to the monitor or “VIDEO-IN” of a DVR camera input.

The Orange and Yellow pair of cores that go in to the terminal block are the data cables. These are the cores that carry the RS485 control signal to the dome from

either the keyboard or the DVR. The next section of the instructions gives more detail on how to connect the RS485 data. Please also read the RS485 WIRING METHODS & TIPS section towards the beginning of these instructions.

Power cable requirement – Assuming a starting voltage of 12V D.C is applied at the PSU end a dome drawing 400mA would allow a 100 metre run of the RG59+2 to deliver 10 volts at the camera end. The highest current draw occurs when the dome starts up. If the voltage of the dome drops below around 10V D.C it will fail to initialise. Obviously you can power the domes locally if you wish.

RS485 connection - *Connecting the Keypad or DVR to the Dome.*



The dome is controlled by an RS485 data signal that is given by either a KEYPAD or a suitable DVR. This data signal tells the dome to pan, tilt, zoom etc. Its important that you read the early section of these instructions to understand the fundamental principle of RS485 cabling techniques so that you get it right.

RS485 has two cores, A and B or sometimes known as RS485 + (A) and RS485 – (B) if you get these two the wrong way around then you will not be able to control the dome. Sometimes installers get the connections right on one dome but not on the other and find only one dome works. They then swap the wires around at the keyboard only to find out one dome has now burst in to life and the other one now failed!!

But they don't put 2 + 2 together and realise their mistake that they have wired one dome different to the other. Take great care getting these the right way around and make sure you wire each dome IDENTICALLY so that if you have to swap the A & B lines over at the keyboard you know all domes are wired the same!!

The PTZ205 series adopts the following RS485 convention;

ORANGE = RS485 + or A
YELLOW = RS485 - or B



You should initially be wiring the dome to the keyboard or DVR on your workshop bench or at least your kitchen table to prove you know how to get everything to work. Once you have done this, it is just a job of extending the cables and physically installing the domes on site. You must obviously take note of the RS485 wiring techniques mentioned at the beginning of these instructions and get the 120ohm resistors correct in the "End of line" domes. Generally speaking you will always be extending the RS485 signal from either the keypad or the dome using a CAT5 or similar cable.

The PTZ730 and PTZ700 are two keypads that can be used with the PTZ205 series. On the rear of the keypads you will see the RS485 connections. Ensure they are connected correctly i.e the RS485 + A line and the RS485 - B line. Note that both these keypads need to be set to the same protocol as the PT dome. Refer to the relevant keypad instruction manuals on the keypad dipswitch settings.

PTZ730 keypad

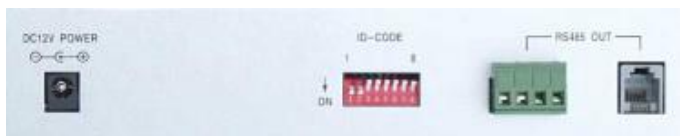

Rear of PTZ730



RS485 connections



RS485 connections

PTZ700 keypad



Rear of PTZ700

If you use cores from two different pairs in the CAT5 cable you will not get the benefit of the shielding effect of the cable twists and the dome will function erratically. You must always use a core from a PAIR, not two cores from two different pairs!!

Connecting the video out of the dome.

The dome has a short BNC lead attached to it. This is the lead that carries the video signal from the built-in camera. You need to extend this lead to the “VIDEO-IN” of the DVR or monitor. Use a good quality RG59 coax cable or similar to do this.

TIP – If you can’t get a picture at the remote end you could always take your test monitor to your PTZ dome and check the picture quality on its own short BNC lead.

If you’re testing the equipment on a workbench you now have a one dome system.

You can use a keyboard or a suitable DVR to control the dome. A suitable DVR would be one with PTZ functionality built into it and preferably Pelco-D protocol. If your DVR has a list of protocols it’s always best to try “Pelco-D” protocol first, as these are very widely available. In the DVR, with Pelco-D set, you must also make sure you set up the “baud-rate” to 2400.

A typical site installation would look like the following diagram on the next page.

It shows the dome connected to the keypad plus how the dome could also be connected to a DVR instead of the keypad or at the same time. DVR’s that have the capabilities of PTZ control will have a terminal or connection on them somewhere, where the dome’s RS485- A and RS485- B line can connect to. Please refer to the individual DVR instructions of how to do this.

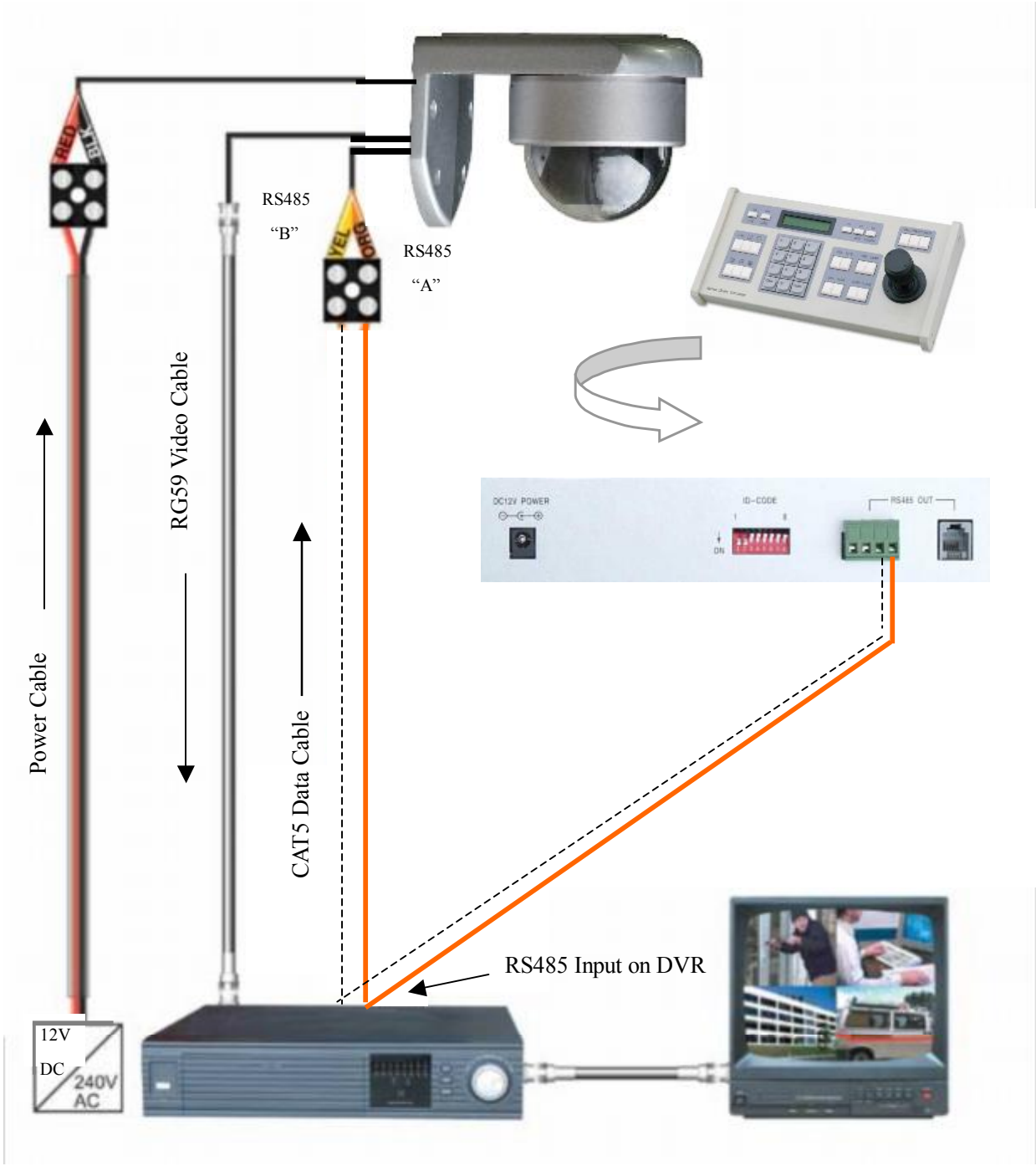

Setting the PTZ dip switches

In order that the PTZ dome can communicate with a control keyboard or DVR, it needs to be set with communication parameters. These are the communication Protocol and the Baud Rate plus a unique numeric address. These parameters are set using dip switches and this dome has two switches, SW1 and SW2.

SW1 Dip Switch

The SW1 dip switch has a bank of 10 switches and switches 1 – 10 are used for setting the unique dome address.

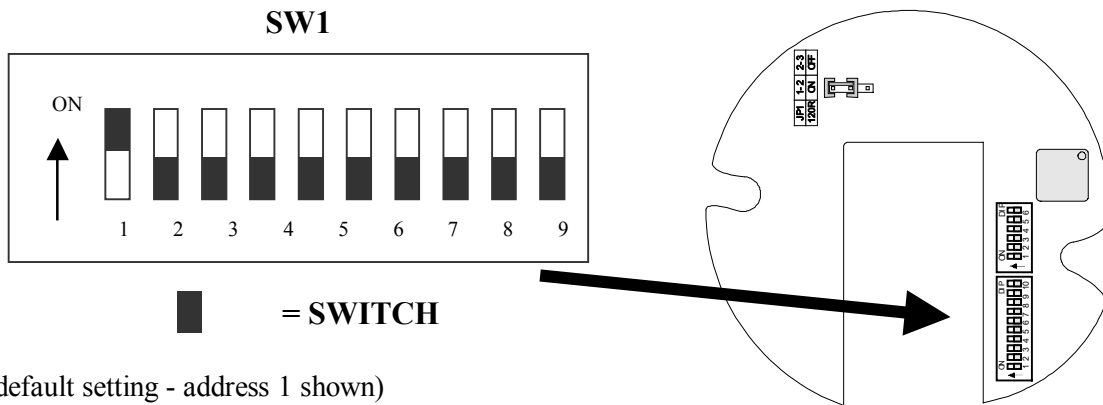

The unique “address” is needed so that if you are using more than one dome on a site, the keyboard “talks” to the right dome when you want it to pan and tilt. If you only have the one dome on the site then the default “address” of “1” is okay and you have no reason to change the dome from this. With multiple dome sites you need to set up each dome address separately. This is accomplished by setting the SW1 dip switch to reflect a unique numeric address. Please see the section “Setting up a unique ADDRESS in a dome.”

SW2 Dip Switch

The SW2 dip switch has a bank of 6 switches and is used for setting the protocol and baud rate. Note that for most SystemQ equipment they should always be set to PELCO-D with 2400 baud rate. Please see the section “Setup of the Protocol and the Default Baud Rate.”

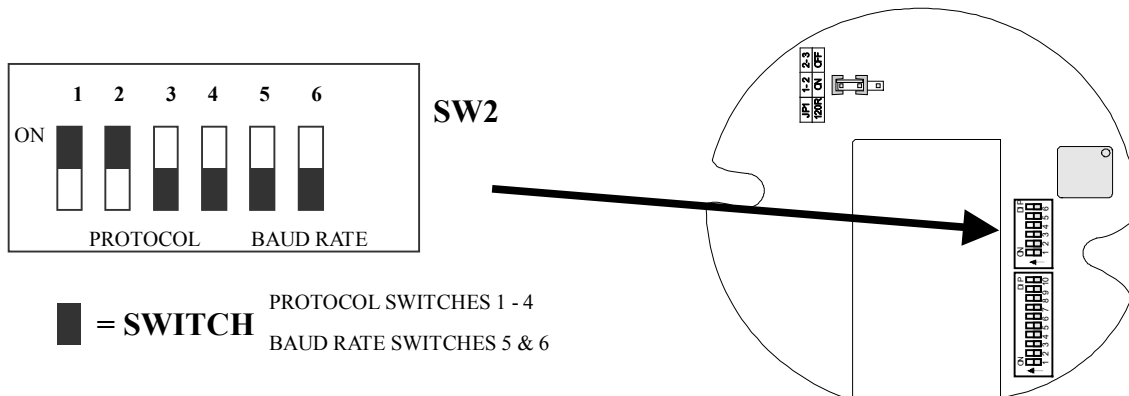

(default setting - Pelco-D 2400 baud shown)

Setting up a unique ADDRESS in a dome –

SW1 is the dip switch used to set the address of the dome camera from 1 – 1023. This dome uses binary notation to allocate the dome address.

For example:

To set the dome address at 1 put switch 1 up.

To set the dome at address 2 put switch 2 up

To set the dome at address 3 put switches 1 & 2 up.

..and so on..

The following table indicates how this is done.

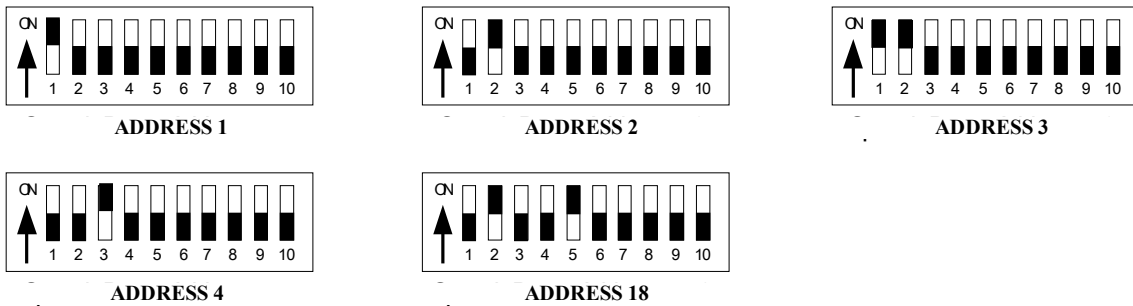

Dome Address	ID-CODE Status									
	DIP-1	DIP-2	DIP-3	DIP-4	DIP-5	DIP-6	DIP-7	DIP-8	DIP-9	DIP-10
1	ON	OFF	OFF	OFF	OFF	OFF	OFF	OFF	OFF	OFF
2	OFF	ON	OFF	OFF	OFF	OFF	OFF	OFF	OFF	OFF
3	ON	ON	OFF	OFF	OFF	OFF	OFF	OFF	OFF	OFF
4	OFF	OFF	ON	OFF	OFF	OFF	OFF	OFF	OFF	OFF
5	ON	OFF	ON	OFF	OFF	OFF	OFF	OFF	OFF	OFF
6	OFF	ON	ON	OFF	OFF	OFF	OFF	OFF	OFF	OFF
7	ON	ON	ON	OFF	OFF	OFF	OFF	OFF	OFF	OFF
8	OFF	OFF	OFF	ON	OFF	OFF	OFF	OFF	OFF	OFF
9	ON	OFF	OFF	ON	OFF	OFF	OFF	OFF	OFF	OFF
10	OFF	ON	OFF	ON	OFF	OFF	OFF	OFF	OFF	OFF
11	ON	ON	OFF	ON	OFF	OFF	OFF	OFF	OFF	OFF
12	OFF	OFF	ON	ON	OFF	OFF	OFF	OFF	OFF	OFF
13	ON	OFF	ON	ON	OFF	OFF	OFF	OFF	OFF	OFF
14	OFF	ON	ON	ON	OFF	OFF	OFF	OFF	OFF	OFF
15	ON	ON	ON	ON	OFF	OFF	OFF	OFF	OFF	OFF
16	OFF	OFF	OFF	OFF	ON	OFF	OFF	OFF	OFF	OFF
17	ON	OFF	OFF	OFF	ON	OFF	OFF	OFF	OFF	OFF
18	OFF	ON	OFF	OFF	ON	OFF	OFF	OFF	OFF	OFF
...
1023	ON	ON	ON	ON	ON	ON	ON	ON	ON	ON

Table 1 Dip Switch Settings for SW1

Setup of the Protocol and the Default Baud Rate

As shown in Table 2, SW2 is used to set the protocol of communication and the baud rate used by the dome camera. DIP-1 to DIP-4 of SW2 is used to select protocols and a maximum of 5 different protocols can be selected.

Pelco-D 2400 is used for most SystemQ equipment.

PELCO D 2400Eps



SW2

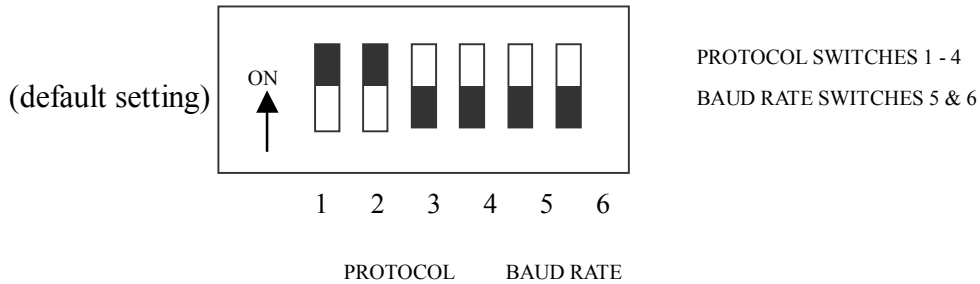

Protocols	DIP status				Normal Baud Rate	
	DIP-1	DIP-2	DIP-3	DIP-4	DIP-5	DIP-6
SAMSUNG	ON	OFF	OFF	OFF	OFF	ON
B01	ON	OFF	OFF	OFF	OFF	ON
PELCO-D	ON	ON	OFF	OFF	OFF	OFF
PELCO-P/4800	OFF	OFF	ON	OFF	ON	OFF
PELCO-P/9600					OFF	ON
ALEC	OFF	ON	ON	ON	OFF	ON

Table 2

The protocols and the states of the coding switches of normal baud rates of these protocols are shown as follows:

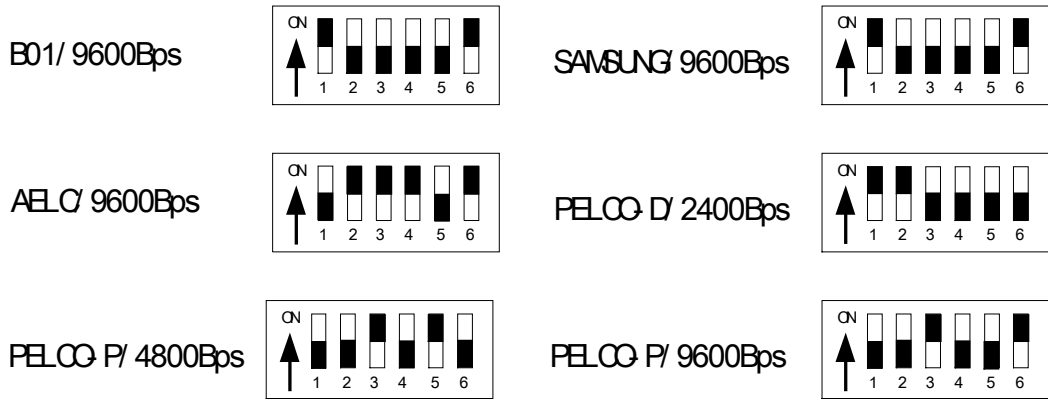

Setup of the Baud Rate of Communication

As shown in Table 2, SW2 is used to set the protocol of communication and the baud rate used by the dome camera. DIP-5 and DIP-6 of SW2 are used to select the baud rate of communication and a maximum of 4 different baud rates can be selected. If the controller adopts a non-standard baud rate, you can adjust it to be identical with that of the controller, as per the following table.

Baud Rate of Communication	DIP-1	DIP-2	DIP-3	DIP-4	Setup of Baud Rate	
					DIP-5	DIP-6
2400bps					OFF	OFF
4800bps					ON	OFF
9600bps					OFF	ON
19200bps					ON	ON

Using the PTZ730 keypad with the excelPTZ series



PTZ730 keypad

NOTE 1: For more detailed instructions in setting up the keypad or using one of our other keypads, please refer to the instruction manual supplied with the product.

NOTE 2: The PTZ730 keypad requires you to press the function key first followed by the value e.g <CAM> 01 <Enter> whereas some keypads e.g PTZ700 require the value first, then the function e.g 01 <CAM> <Enter>

When you first take the keyboard out of the box you will need to set it up for the domes that you are using.

The dome you have purchased has the default settings of; PELCO-D 2400-BAUD rate Address 1

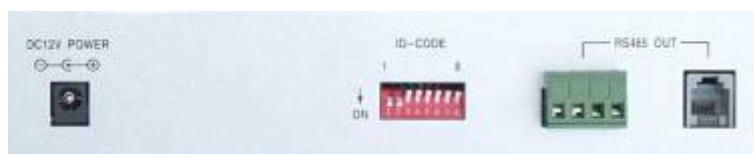

Rear of PTZ730 keypad

First read through the keypad instruction manual supplied. Set the protocol and baud rate in the keypad using the dipswitches on the rear of the unit. Note that all PTZ domes controlled by this keypad must have identical protocol and baud rate settings. The manual supplied with the keypad will show you what these settings should be.

Next connect the RS485 connections from the dome/s ensuring that the A and B lines are connected correctly.

Finally connect the power supply. Both the PTZ730 and PTZ700 keypads require a 12V DC PSU (500mA minimum). It is recommended to use a POW800 for this purpose. Now press the keypad ON button.

Select a PTZ camera by pressing CAM button followed by camera address and Enter*. The LCD display will indicate the camera channel selected. CAM 01 indicates that the keyboard is ready to talk to camera with address 1, if you have another dome set at camera address 2, press CAM button followed by 02 and Enter. This would change the display screen to CAM 02.

If you have multiple domes you will need to change the address of each dome so they are different but PLEASE LEAVE THE DOMES ON PELCO-D 2400 BAUD RATE.

- see NOTE 2 above.

PRESETS and other functions.

The dome has up to 32 presets that once programmed with stay in the domes non-volatile memory so they will be retained even after a power cut.

What is a preset? A preset is a particular area or object that the dome was looking at and has been stored into its memory so when the preset is “called-up” the dome will select the area again without the operator using the joystick to do this. This means that you could for example store a PRESET of a car-park entrance. When the operator calls up this preset the dome automatically moves to this location. By storing more than one preset you can add even more functionality to the dome. By having two presets, you can then get the dome to “SCAN” between the two locations.

Having 3 or more presets you can get the dome to go on a TOUR (PATROL) of the presets. When you run the patrol the dome goes to one preset, then waits a short period then on to the next preset and so on. The dome continues to cycle around this patrol until you cancel it. The length of time the camera stays at each location is set in this dome at 4 seconds and the speed of travel between each preset point is 7.5° per second.

In the dome some preset numbers are reserved for special functions, these are listed as follows;

PRESET No.	Special function	What you press at the keyboard	
		<i>Press XX then CALL (XX = preset No)</i>	<i>Press XX then PRESET (XX= preset No)</i>
51	Auto Scan / Tour	Starts an Auto Scan	Starts a TOUR
52	Auto Scan	-	The location the Auto Scan starts from.
53	Auto Scan	-	The location the Auto Scan ends at

If you wish to use the Auto Scan function YOU MUST FIRST USE preset 52 as the starting point of the scan and preset 53 as the ending point of the scan.

Note that the PTZ700 keypad uses different commands. See following details.

PRESETS -How to set up a preset using keypad

***NOTE: Different keypads may have different formats for sending commands.**

Aim the dome where you want it to look and zoom in or out to get the correct scene. Now press the following keys on the keypad : **xx PRESET** (where **xx** is the preset number you wish to store). For example **01 PRESET** would store **PRESET 01** and the camera would always go to this location when **01** is “CALLED”. Ensure that you do not keep the preset button depressed, as this will delete the preset.

To test if the preset is stored correctly use the joystick to move the camera to a point in a new location. Now press **xx CALL** (where **xx** is the preset you wish the camera to go to). In this example if you press **01 CALL** the dome should go straight to the PRESET 01 location.

TIP -You may wish to write down a list of presets that you have stored next to the keypad for the operator.

CALLING a preset

This may be as follows:

PRESET 01 = MAIN GATE

PRESET 02 = ENTRANCE DOOR

PRESET 03 = FIRE ESCAPE

PRESET 04 = EMERGENCY EXIT

PRESET 05 = CAR PARK

When the operator wishes to quickly move to the MAIN GATE view all he has to do is to press **01 CALL**.

To go to the EMERGENCY EXIT he would press **04 CALL** and so on.

To call up any previously stored preset camera location, simply press **xx CALL**, where **xx** is the preset number.

AUTO SCAN- How to set it up

Auto-scan scans between the two presets 52 & 53 as indicated in the previous table shown.

STEP 1-Aim the camera where you wish to start scanning from, now press **52 PRESET or AUTO ON**

STEP 2-Aim the camera where you wish to end scanning from, now press **53 PRESET or AUTO OFF**

The dome now knows the two outer limits of its scan.

To start an Auto Scan press **51 CALL or AUTO SHOT**

TIP - To stop the scan just move the joystick slightly.

Patrols (Tours) – How to set them up and use them

A patrol (tour) is simply a collection of at least three preset camera locations that are run in sequence with the dome stopping at each location for four seconds then moving on to the next preset. You can put several presets that are at the same location to lengthen this time.

For example, you could use a patrol so that an outside dome camera points at a gate, then at a side doorway, then a car park and finally a delivery bay, before repeating the whole cycle again. Patrols can be useful for both outside and internal domes. For a shop they could be used to cover key areas like clothes rails, tills and changing rooms in a sequence.

To set up a patrol you need to set up the individual stop points where the camera will pause. These are called *presets*. See the following example.

An example four preset mini-tour

Setting the presets using the keypad

STEP 1- Using the keypad joystick, move to where you wish to start the tour and then press **01 PRESET**

STEP 2- Now move to the next location and press **02 PRESET**

STEP 3- Now move to the third location and press **03 PRESET**

STEP 4- Finally move to where you wish to end the tour and press **04 PRESET**

STEP 5- To run the tour press **51 PRESET** or **01 SHOT (for PTZ700 keypad)**

To stop the tour, just move the joystick slightly.

Deleting a preset

You may wish to delete a preset.

To do this press **xx CLEAR** or **PRESET xx OFF**
(xx = preset number).

For example to delete preset 1, enter **01 CLEAR** or **PRESET 01 OFF**

Obviously if you wish to overwrite a preset with a new location, simply aim the camera at the new location and store the preset as normal, this will simply overwrite the old preset.

Controlling one camera then another.

If you look at the image of the LCD display you can see the CAM=001 indicates that the keyboard is ready to talk to camera with address 1. In the dome the address 1 is set as default in the factory. You need to alter the DIP-switches within the domes to address 2, 3 etc if you have multiple domes on the same site, refer to the previous instructions how to set the DIP Switches. If you have another dome set at camera address 2, press 2 followed by CAM. This would change the screen to CAM=002. And so on.

Installation Instructions

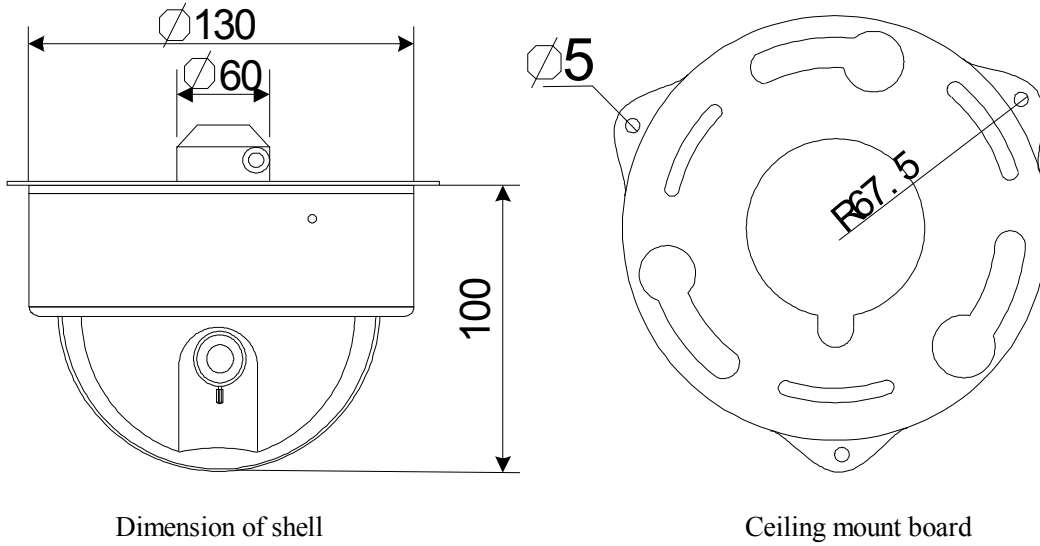

Dimensions

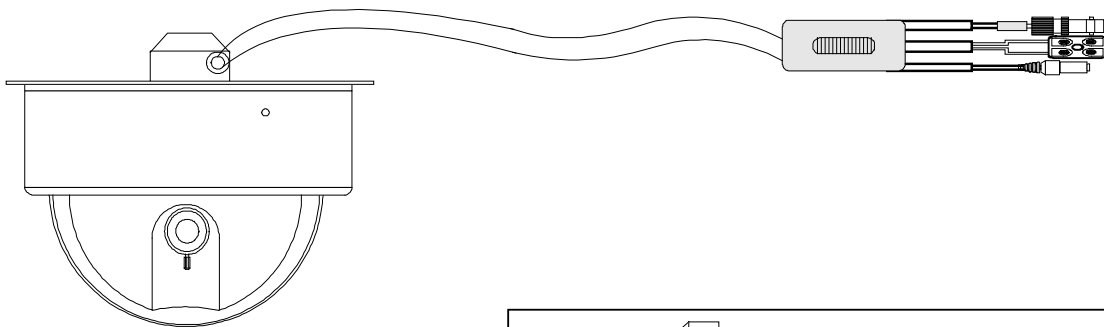

Installation

a) Ceiling mount

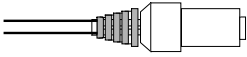
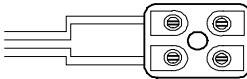
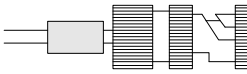

	POWER	POWER DC12V
	Orange	Orange: RS485+
	Yellow	Yellow: RS485-
	VIDEO	VIDEO CUT

b) Suspended installation

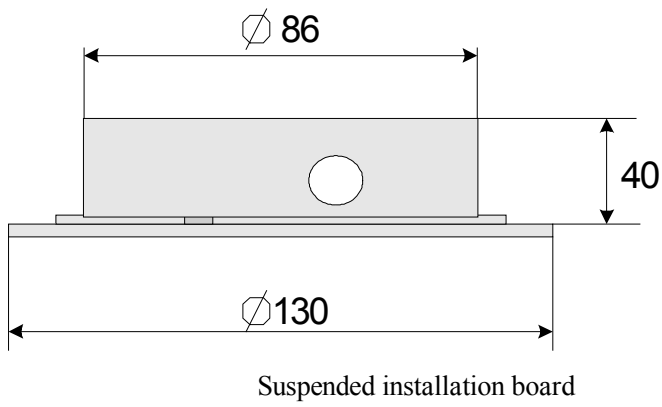
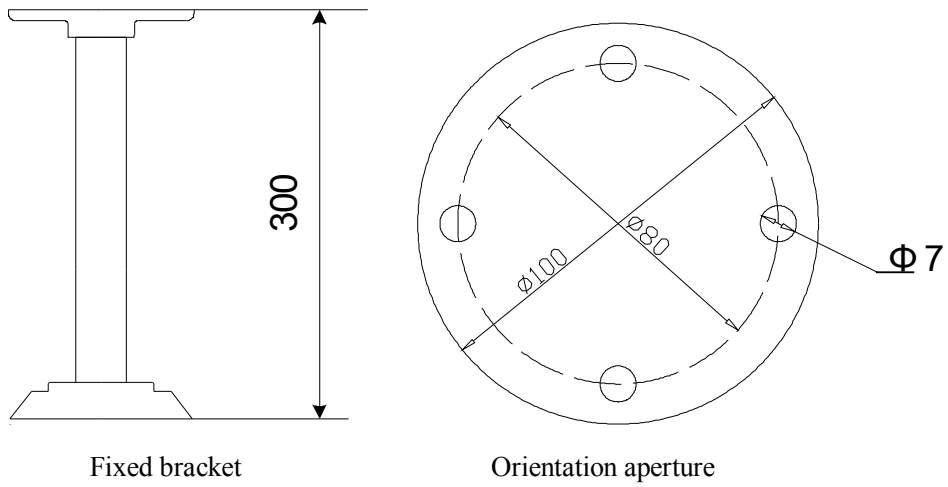

a) Wall mount

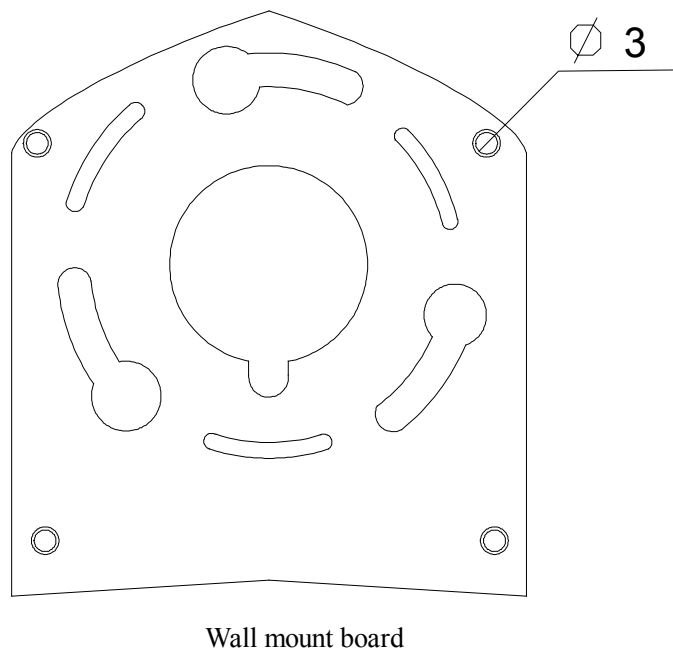

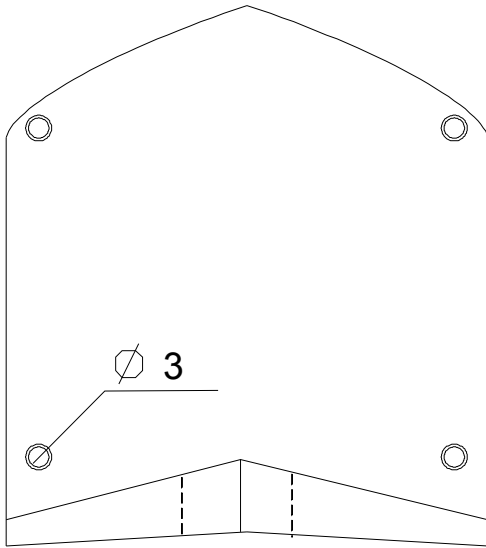

Fixed bracket with installation board

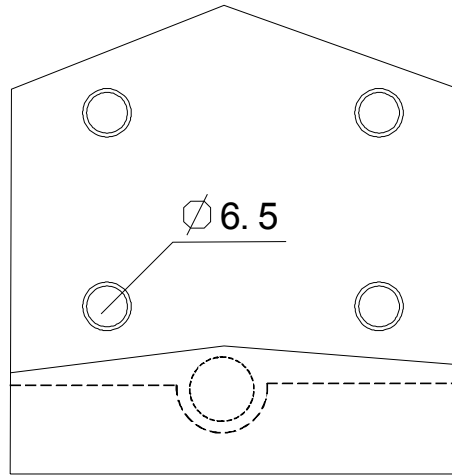

Fixed bracket with wall interface

Installation Steps

Ceiling mount

- 1) Drill a 6cm hole in ceiling. This is used for installing the dome cable housing and hiding the connection cable.
- 2) Take out the two fixed Allen screws using the special Allen key.

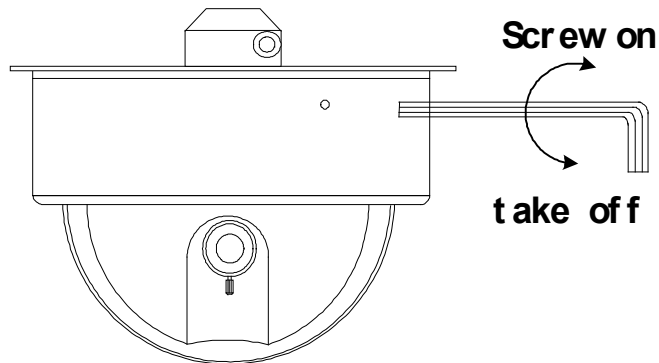

- 3) Due to the two rubber waterproof sealing rings inside the dome housing you will need to remove the metal shell using a screwdriver and carefully prise upwards.

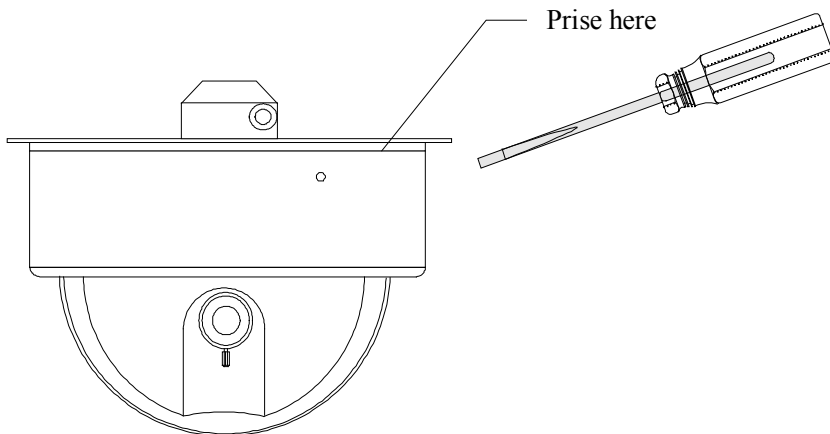

-
- 4) Remove the black camera protection shroud by removing the small Philips screws so that you can set the dip switches for the camera address, protocol and baud rate. Set the jumper for the 120Ω termination resistor. Instructions for setting these are found earlier in this manual.

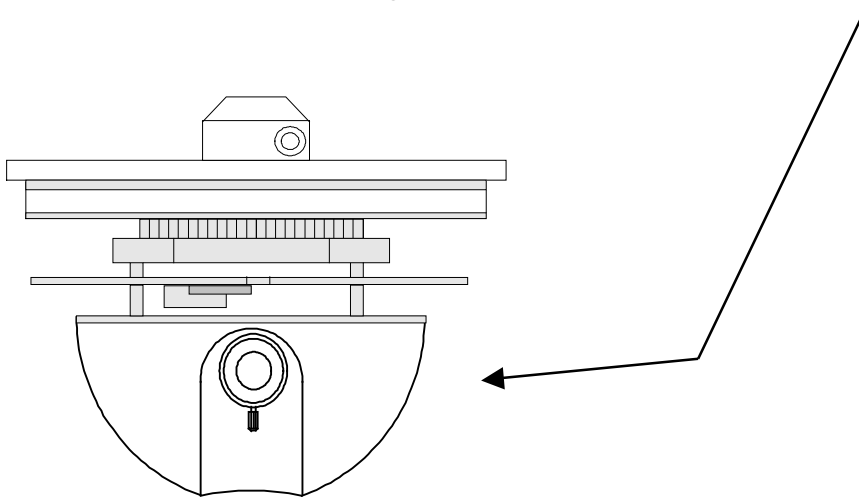

- 5) Refit the camera protection shroud and push the unit into the metal shell and refit the screws.
- 6) Hide the cable in the ceiling aperture and fix the dome to the ceiling.
- 7) Ensure the video, power and data cables are connected as per instructions earlier in this manual.

Suspended mounting

- 1) Set the dip switches and jumper as per instructions above.
- 2) Remove the ceiling mount board and fit the suspending mount bracket. Ensure the connection cable is free.

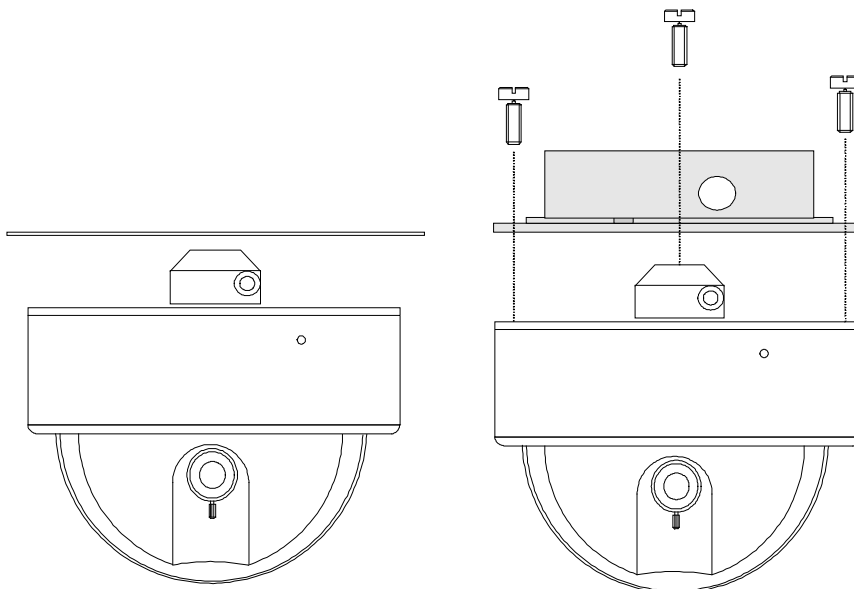

- 3) Feed the connection cable through the fixed bracket and then secure the bracket to the dome.

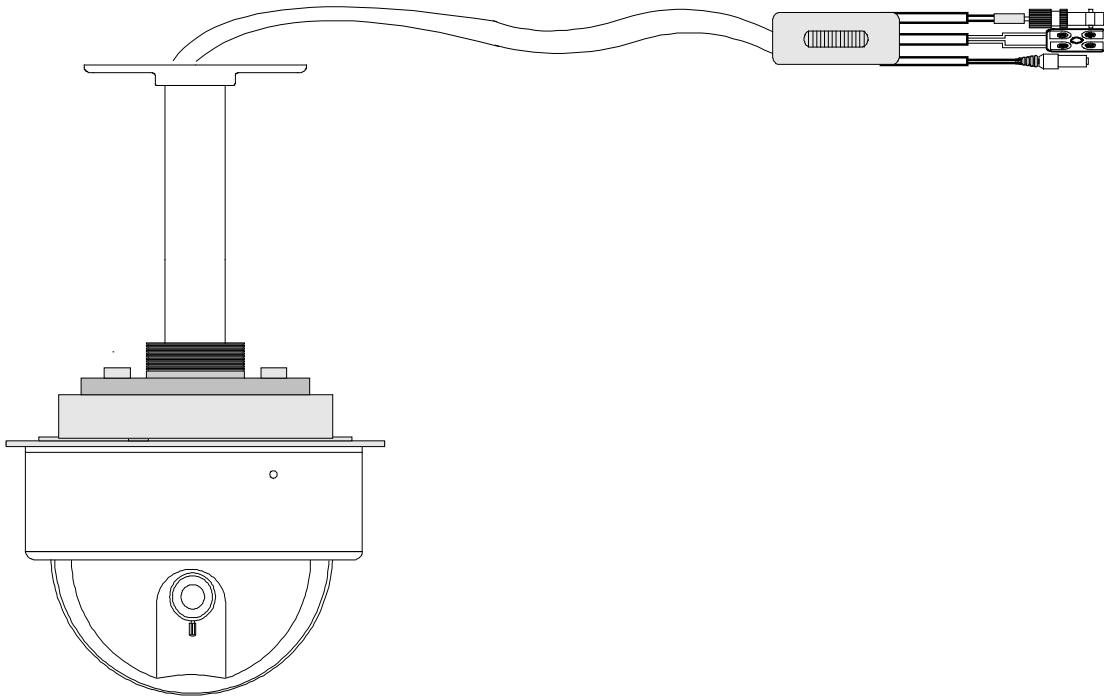

- 4) Correctly fit the connection cable.

Wall mounting

- 1) Locate the position for mounting the wall bracket.
- 2) Remove the ceiling installation board and replace with the wall installation board feeding the connection cable across the front on the bracket through the cable aperture.
- 3) Fit the dome to the wall bracket using the bolts provided.

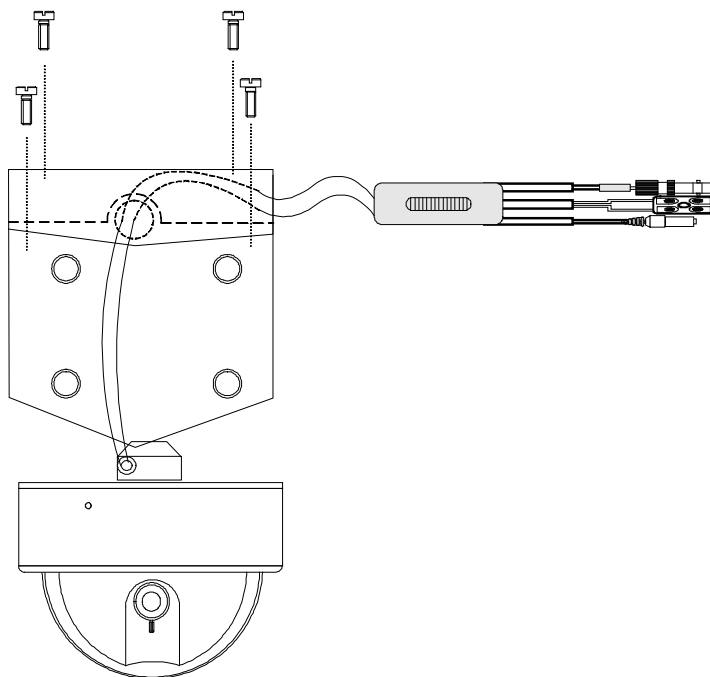

- 4) Fit the wall bracket and dome to the wall using your own fixing bolts.

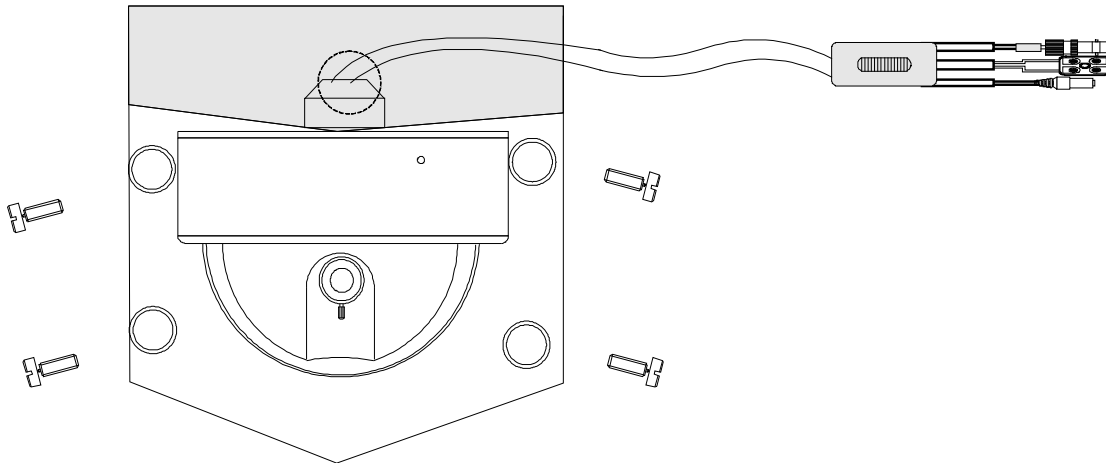

- 5) Correctly fit the connection cable.

All specifications are approximate. Kovert.com reserves the right to change any product specifications or features without notice. Whilst every effort is made to ensure that these instructions are complete and accurate, kovert.com cannot be held responsible in any way for any losses, no matter how they arise, from errors or omissions in these instructions, or the performance or non-performance of the equipment that these instructions refer to.



WEE/CG078355

This symbol on the products and/or accompanying documents means that used electronic equipment must not be mixed with general household waste. For treatment, recovery and recycling please return this unit to your trade supplier or local designated collection point as defined by your local council.

Technical Specifications

Specifications	TV SYSTEM	PAL
	Image Sensor	1/3" CCD Image Sensor
	CCD	380 TVL
	VF Output	Compound Signal 1.0Vp-p/75Ω
	Scanning System	625 lines, 50 fields/sec
	Power Supply	DC12V±10% 400mA (use a 1Amp power supply)
	Power Consumption	12VA Fan/Heater excluded
	Installation	Ceiling Installation/Wall mounting/In-Ceiling Installation
	Relative Temperature	10°C ~ 75°C
	Operation Temperature	0°C ~ 40°C
	Waterproof standard	IP66
Camera Function	Horizontal Resolution	380 TVL/ 470 TVL (enhanced)
	Signal / Noise ratio	52db(min)/60db(TYP) (AGC OFF)
	Digital zoom(x2)	Optional
	Electronic Shutter	1/50—1/120000sec
	Lowest Temperature	0.5 lux F1.2 5600°K
	Mirror function	Optional
	Gain Control	Optional
	Iris Control	Electronic
	White Balance	Optional
	Image Quality Compensation	Vertical & Horizontal
	Basic Functions of Dome	Horizontal Turning
Vertical Turning		0~12°/s 0°~90° Elevation Angle
Preset Positions		32 Positions
Patrol Function		Tour with maximum 16 preset positions