

Traditional PTZ range

Installation and Operation Manual

Outdoor HIGH Speed Traditional Pan Tilt Zoom 24V AC model with IR Day-Night Module

Models Covered
PTZ800
PTZ827



Version 1.0

CONTENTS TABLE

Description	Page No.
Contents	2
Safety Precautions	3
Key Functions	4
Special PTZ800 Features – 2 channel alarm input activation	5
Getting the dome up & running	5
Overview – introduction to fitting PTZ equipment	6
RS485 Wiring methods & Tips	8
The connection of a 120 ohm termination resistor	9
Overcoming RS485 data loss using an RS485 distributor	10
Setting up the Traditional PTZ Camera	12
RS485 connection – Connecting the Keypad or DVR to the PTZ	13
Connecting the video out of the PTZ	15
If you are using more than one dome on a site	17
Setting up a unique address in a dome	17
Setup of the Protocol and the Default Baud Rate	18
Using the PTZ730 keypad with the Traditional PTZ series	20
Presets and other functions	21
Patrols (Tours) – How to set them up and use them	22
Auto Scan – How to set it up – Calling the Auto Scan	25
Record Pattern – What is a record pattern?	26
What is the difference between a pattern & a patrol (tour)?	26
How to set it up – Running the Record Pattern	26
Using the PTZ800's Advanced Functions	28
Using the Advanced Menu System	29
Display Setup	30
Camera Setup	32
Control Setup	34
Program	36
CAM Default Set	38
Reset PT	39
Exit	40
Controlling one camera then another	40
Special Presets	41
Physical installation of the PTZ800	42
Wall Mounting	43
Base Plate Mounting	44
Wiring connections – Alarm connections	46
2 channel alarm input activation	47
Technical Data Table	48
Appendix A: General Information – Troubleshooting	49

Please read this operation manual carefully
before installing and using this unit !!!!



Please read the following;

1. Please read the operation manual carefully before installing and operating the product.
2. The actual dome requires a 24v AC power supply. The rated input voltage of the camera is 12V!!!! This gets its power from the dome and does not require a separate PSU. Do not connect 24V AC to the camera under any circumstances!!
3. During the course of transportation, storage and installation, the product should be handled with care avoiding vibration and any weight pressure, which may cause damage to the sophisticated optical and electronic equipment inside the machine.
4. Do not attempt to disassemble the camera. In order to prevent electric shock, do not remove screws or covers. There are no user-serviceable parts inside the camera.
5. Always use and stick to current electrical safety standards to install and use the dome. Use a correctly rated power supply. The RS-485 and video signal cables should be kept way from other high voltage equipment such as mains cables and especially fluorescent lights. Using an anti surge protection device is recommended to prevent damage to the PTZs from lightning and mains surges. Damage to PTZs by lightning or mains voltage surges is not covered under the PTZ warranty.
6. Do not operate in areas exceeding the stipulated limitations concerning temperature, humidity and power supply.
7. Do not aim the camera directly towards the sun or an extreme light source whether it is switched on or not. Do not let the camera focus on bright and stationery objects for a long time. Doing either of these may damage the camera.
8. Do not use strong detergents to clean the main body of the PTZ as these may damage the paintwork. Wipe dirt with dry cloth. If needed a *mild* detergent can be used.
9. Operate the PTZ with care to avoid shock or vibration. If operated incorrectly, the PTZ could be damaged.
10. Ensure the PTZ is not dropped. Never mount the unit on a structure that cannot support its weight.
11. If necessary, use a commercial lens cleaning paper to clear the lens windows. Gently wipe the lens window until clean.

KEY FUNCTIONS

Description of Functions

This intelligent traditional PTZ is a hi-tech CCTV product, which incorporates a high-clarity colour camera. It has a panoramic variable speed PAN/TILT movement, a multifunctional decoder, a character generator and an on-board processor for logic handling. The PTZ is easy to connect, install, maintain and operate, and has many features. The PTZ is compact and has a very strong structure with a traditional housing.

1. Integrated Multi-Protocol Decoder

- a. The integrated multifunctional decoder can communicate with 16 different protocols. The baud rate can be independently set allowing compatibility with numerous systems with selectable baud rates from 2400 bps to 19200 bps. Dip switches control the selection of the protocol and baud rate thus making this PTZ camera easy to set up and use.
- b. This PTZ uses RS485 serial control and can address from 1 to 1023 cameras using binary addresses.

2. Integrated Speed-Variable PAN/TILT

- a. The PTZ can turn 360° horizontally and continuously with unlimited positions with an adjustable speed from 0° - 40° per second and turning +33° to - 80° with an adjustable speed of 0° - 20° per second where wind speed is less than 50mph.
- b. From a preset position the PTZ has a horizontal speed of 0° - 100° per second while the vertical speed is 0° - 40° per second where wind speed is less than 50mph.
- c. The maximum wind speed tested is 130mph.

3. High Intelligent Settings

- a. This PTZ can store up to 128 preset positions in non-volatile memory that are not lost with a power failure. Refer to the section “Presets and other functions.”
- b. The PTZ can scan horizontally between two points and the scan speed can be modified. The PTZ can scan a range larger or smaller than 180° between any two points with adjustable speed settings. Refer to the section on “Auto Scan.”
- c. Six sets of tours (patrols) each with 16 preset positions can be programmed. The running speed and the dwell times are adjustable. Refer to the section on “Patrols (Tours).”
- d. The PTZ camera can simulate a route operated by you within a 40 second interval by utilising the Record Pattern facility. Refer to the section on “Record Pattern.”
- d. The logical structure of the menu makes all setups and programming of the PTZ camera more convenient and easy to operate.
- e. Proportional pan function. The PTZ travel speed will depend upon the extent of the zoom coverage. In telephoto zoom mode, the pan and tilt speeds will be slower for a given amount of joystick movement than that in wide zoom mode. This keeps the image from moving too fast on the monitor when there is a large amount of zoom coverage. This slowing down does not occur when going to a preset, but does occur in turbo mode when the high speed zoom is selected.

4. Special PTZ800 Features

Weatherproof

This PTZ is IP66 weatherproof rated.

Control Features

Automatic temperature control feature and manual control for rain wiper and defroster.

2 channel alarm input activation

One of the special features of this PTZ is that it has two in-built alarm channels to call two independent presets. This means that for example you may have a door contact and when the contact is closed, it sends a 0 volt alarm switch to the PTZ on one of the two alarm channels. The PTZ will then call a previously set preset position and lock the camera onto that position. When more than one alarm input channel is utilised and activated, the PTZ will switch to the second channel after two seconds. However once an alarm input channel has been activated, the PTZ will remain locked to the preset position/s and will not resume a patrol, auto scan or a record pattern until the alarm condition is cleared. However there is a HOME menu that allows the PTZ to return to a specified preset or to continue a selected tour. To set the alarm channel/s you must switch on the relevant external alarm by setting Preset 54 for channel 1 and setting Preset 55 for channel 2. Then in Control Setup menu set the actual preset numbers for each alarm.

Getting the dome up and running!



You **MUST** connect up the PTZ and your control equipment on a workbench or kitchen table before the actual site installation and **CHECK YOU KNOW HOW TO INSTALL IT CORRECTLY!!!!!!!!!!!!!!!!!!!!!!**.

By doing this you can set-up any DIP switches, adjust the camera, and learn about how it operates before taking it to site. This will save you hours of time on-site trying to work out why a particular item doesn't function as you expected it to. There is nothing worse than installing something and then having to take it down to see how to get it working!! Do the learning curve in the comfort of your own premises!!!!

**Do you KNOW how to install PTZ equipment that is
controlled by RS485 data signals?**

If not please read the following introduction to PTZ >>>....

Overview- introduction to fitting PTZ equipment

Generally speaking, PTZ cameras requires four things;

- 1- They require a power supply and a cable to supply this power to the dome. Often, external PTZs are 24V A.C but some mini pan and tilt domes are 12V.
- 2- They require a cable to get the video signal back to the monitor or recording device.
- 3- They require a cable to transmit the “RS485 control signal” from the keypad or DVR to tell the unit to pan, tilt and zoom etc.
- 4- They require something to control them, either a keypad or a DVR.

The following diagram indicates the basic cable requirements for a PTZ system.

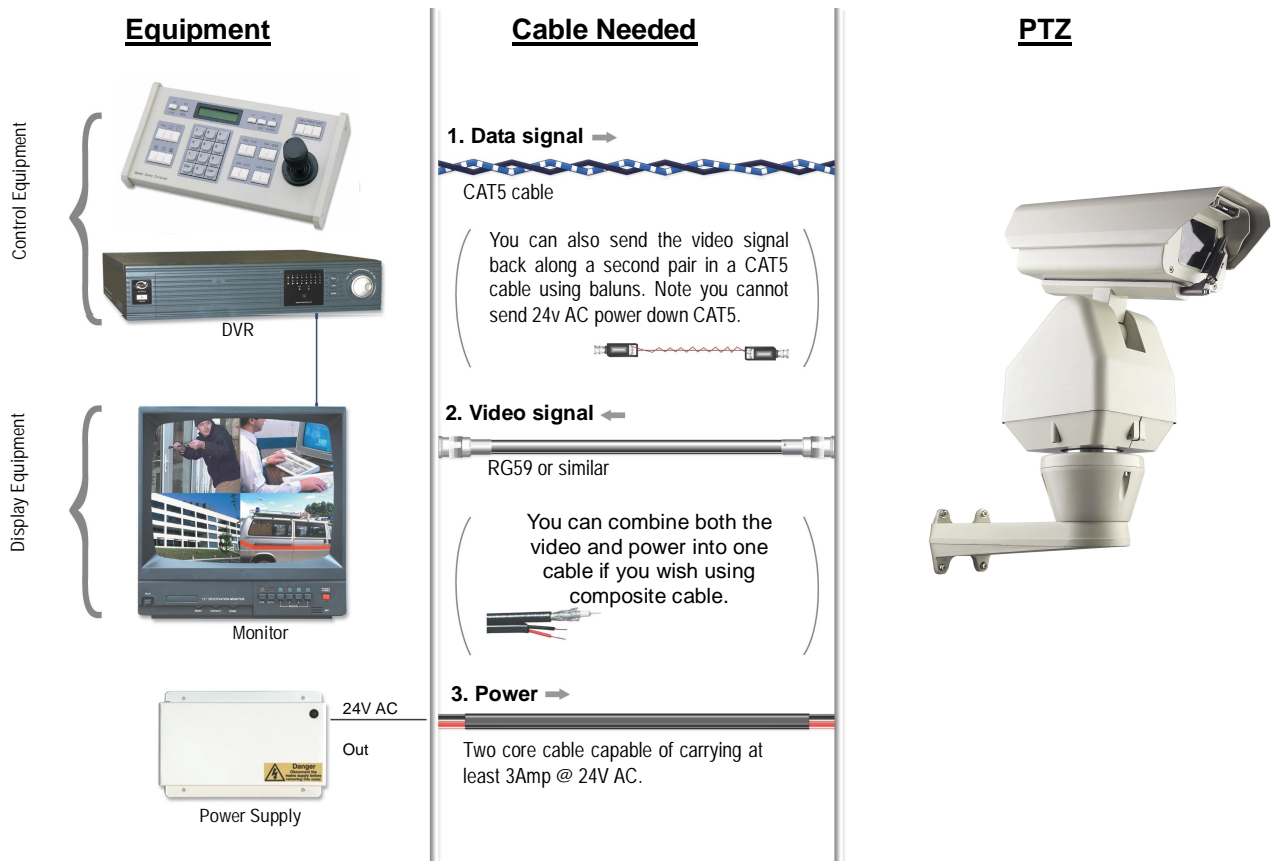

You can get “composite” cables that will carry both the power and the video signals or PTZ Combo cable that carries all three cables in one. You may choose to power the PTZ locally to it, so you may only need to get the video signal back from the PTZ and the RS485 control signals to it. If this is the case you may choose to use a pair of BALUNS. By using baluns you can send the video signal and control signal down the same CAT5 cable just using different cores for each signal.

The control signal (RS485) is nearly always sent along a “twisted-pair” type cable. The twists in the cable help prevent interference affecting the data signal by “shielding” it. Many installation companies use a CAT5 type or similar cable to run out to the PTZs to carry the data signal.

If you are considering using baluns please note - DVR’s tend to require very good video signals to function correctly and “passive baluns” can loose some signal strength over the 50 metre mark so try to restrict the use of passive baluns to below 50 metre cable runs when using them with DVRs. Above this distance perhaps consider an active balun. Active baluns require power, passive baluns do not.

You can mix and match how you wire up your PTZ installation and the following general diagram gives you a guideline about how to do it. Remember this is a GUIDE and is not an instruction what to fit!

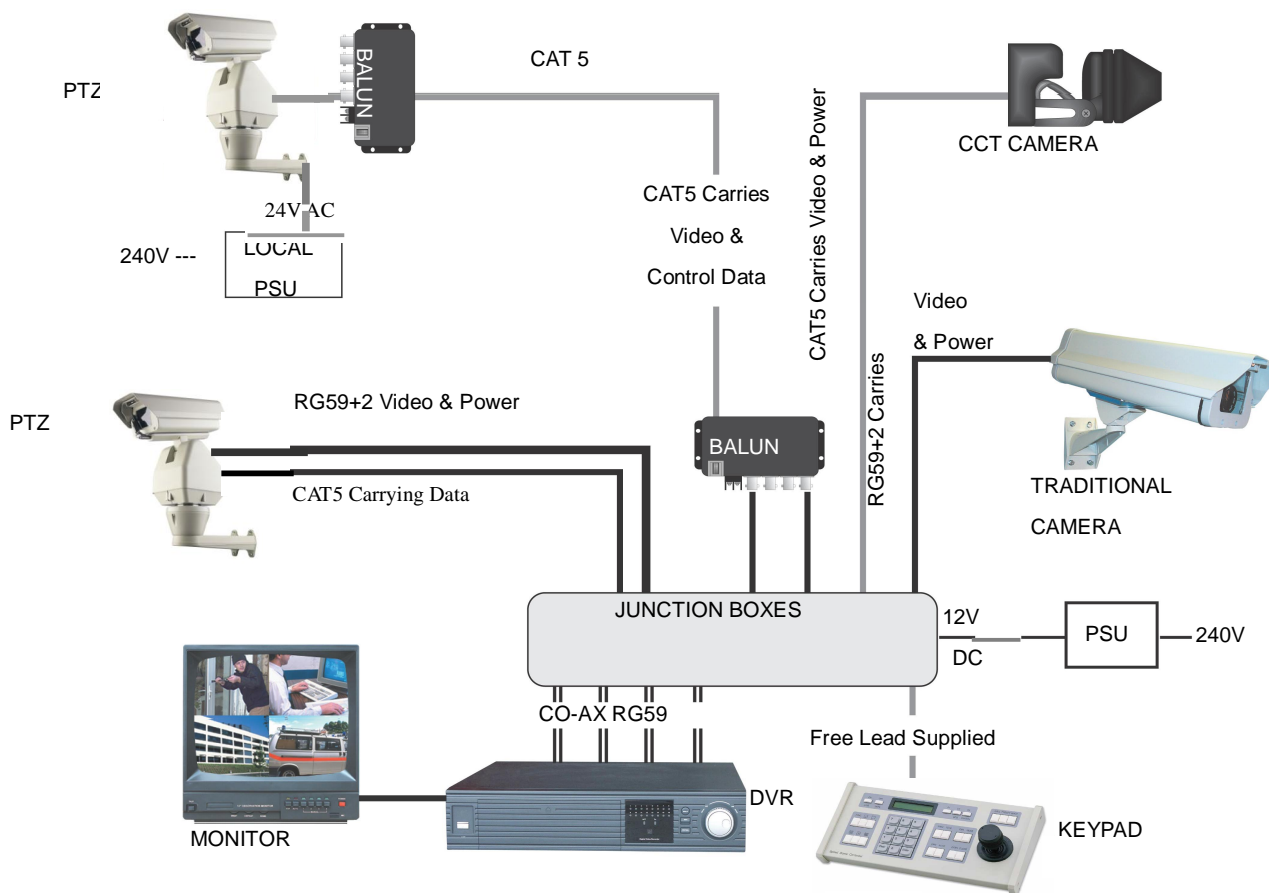

Many installation companies can get the power and video signal correct, but struggle with the control of the PTZ using the keypad or DVR using the RS485 data.

The key to successfully installing the data cabling to the PTZ is to get the basics right. Use a quality data cable such as CAT5 (never use just a standard untwisted cable such as alarm cable for the RS485 signal).

Also, you must follow the RS485 wiring convention; the following section explains this.

RS485 Wiring methods & Tips >>>>

1. Characteristics of RS485

As specified by RS485 standards, RS485 is a half-duplex data transmission type with characteristic impedance of 120Ω . The maximum load capacity is 32 units (PTZs, keyboards and DVRs).

2. Transmission distances of RS485 Signals using CAT5 or similar cables

Selecting a CAT5 or similar sized twisted pair data transmission cable, the maximum theoretical transmitting distances are as follows:

Baud Rate	<u>Maximum</u> Transmitting Distance
2400 Bps (PELCO-D)	1500m
4800 bps	1000m
9600 bps	600m

PLEASE NOTE - Using inferior cables, or installing the PTZ in an environment with strong electromagnetic interference, or connecting a lot of PTZs to the same cable carrying the RS485 signal will reduce the maximum transmitting distance.

3. RS485 Connection methods

METHOD 1 – DAISY CHAIN CONNECTION.

The general RS485 standard recommends a “daisy chain” connection of equipment that is to be controlled. This means that the control cable is looped out of the one PTZ/dome to the next PTZ/dome and so on. The last PTZ/dome in the line is then fitted with what is known as a “termination resistor”. This has a value of 120Ω .

The resistor is built in the PTZs and is activated by moving the appropriate dipswitch in the PTZ. The keyboard itself generally has a built-in 120Ω resistor. These termination resistors help make the signal more stable and give the system better reliability so the PTZ functions as expected. A common mistake installers make is not making sure the 120Ω resistor is switched ON in the LAST PTZ. Also installers often select the resistor to ON in another PTZ in the chain, these errors will make control of the PTZ unpredictable.

A simplified Daisy chain is shown below;

This first diagram shows the cables looping in one PTZ and out of another.

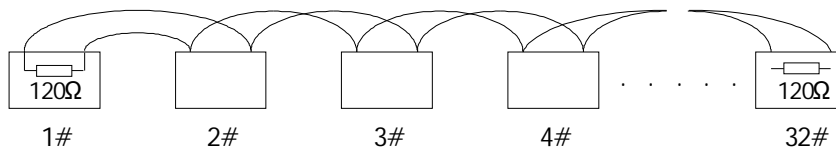

Standard Daisy-Chain connection for the RS485 PTZ control signal

(just the last PTZ only has the 120Ω resistor set to on, the first device is the keyboard and has the 120Ω built in as default)

This next diagram is a slight variation on the Daisy Chain arrangement. Again it's one cable going out to all the PTZs but instead of the cable going into each PTZ then back out to the next one, a junction box is used to "Spur-Off" to each PTZ. Whilst this can be done THE SPUR LENGTH (D) must be NO MORE THAN 10 metres!!!!!! The overall cable length between the Controller and the last dome is limited to around 300 metres in such an arrangement.

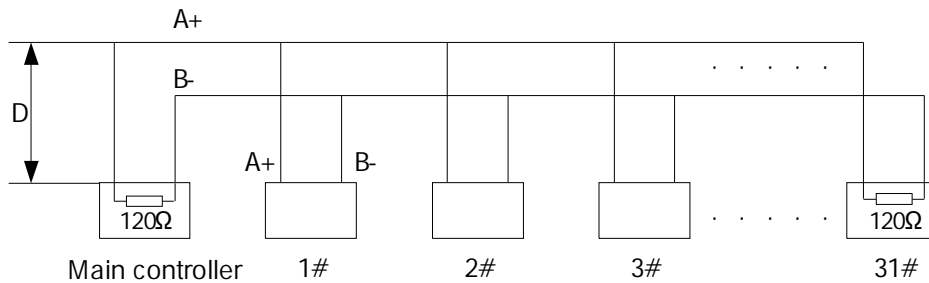

Daisy-Chain connection WITH SHORT SPURS for the RS485 PTZ control signal

(one main radial with very short spurs to each PTZ off it, keeping the spurs to less than 10 meters)

TIP - The connection of a 120Ω termination resistor: The termination resistor is fitted in the base of the PTZ and set by moving dipswitch 1 on a 4 bit dipswitch to 'ON'.

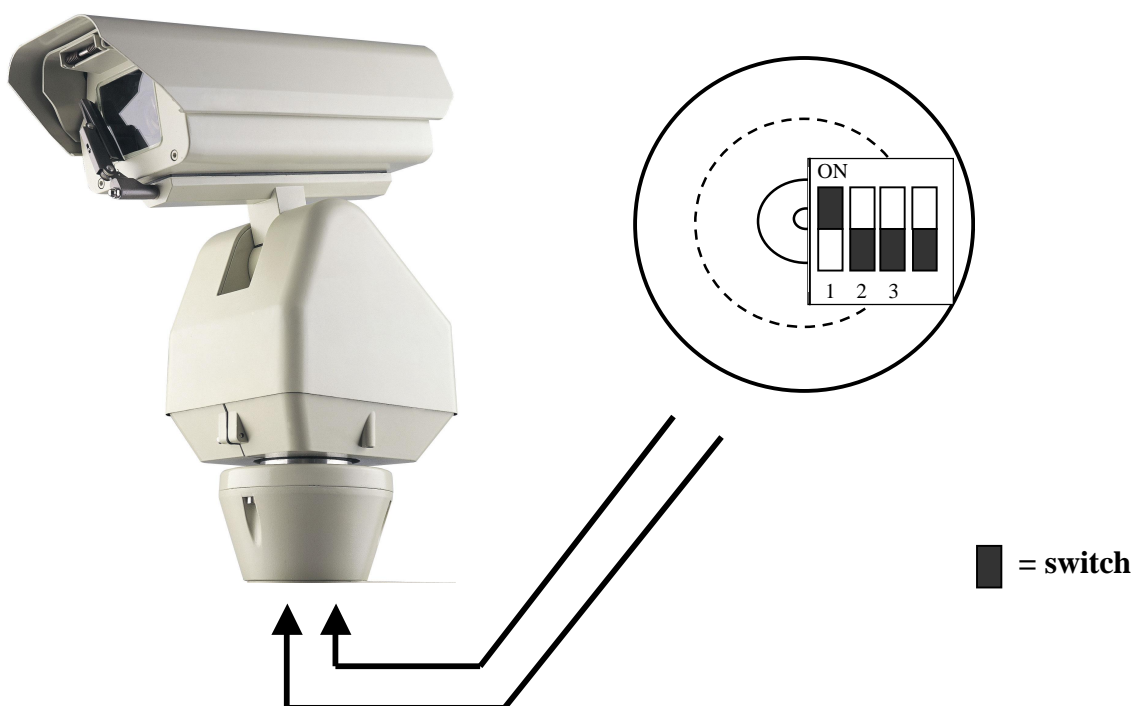

STAR method of connection.

In some circumstances you may need to adopt a star configuration for practical purposes. For instance, all the PTZs may be so scattered on a large site that running out separate spurs to each dome in a “STAR” array is the only practical solution.

So how do you do this in practice?

The termination resistors must be connected to the two domes that are furthest away from each other, such as PTZs 3 and 5 in the following “Star diagram”. Note that all the other PTZs do not have the 120ohm resistor connected. The resistors are already fitted to the PTZ’s PCB but by default are not in circuit. To put them in circuit you must move the small “jumper” as previously indicated.

As the star configuration is not in conformity with the requirements of RS485 standards, problems such as signal reflections may arise, especially when there are long cable connections. The results are that control signals are decreased and the PTZ may not respond to, or just responds intermittently to the controller.

If your STAR circuit is not too extensive with each spur in the region of 20-50 metres you can expect quite good reliable performance using this technique. If you experience any problems though, there is a RS485 distribution box available CODE PT750 to help overcome any problems.

The Star circuit for wiring PTZ’s.

The two furthest domes need the 120ohm resistors enabling, by moving the “Jumper”
In this example it’s domes 3 &5.

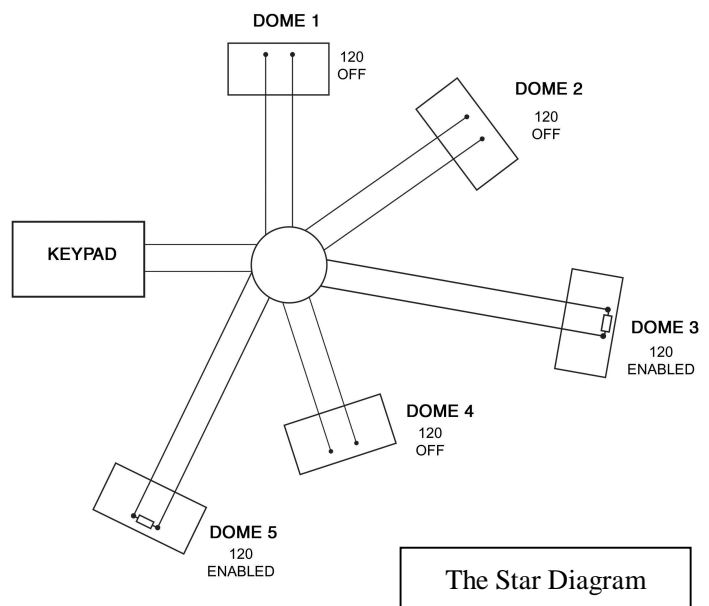

Overcoming RS485 data loss using an RS485 distributor

In the real world not everything always works exactly as it’s expected to!

RS485 data signals that control the PTZs’ movements are tiny signals that can get corrupted for many reasons. Poor cable quality, not using a PAIR of cores from a CAT5 but using one core from TWO separate pairs, running the CAT5 cable near mains equipment such as florescent lighting all will have a detrimental effect on the signal. These are things that you can correct with good installation practices.

Where you wish to run several separate CAT5 cables out to send the RS485 data signal out to the PTZs you are in effect correcting the STAR method of RS485 data distribution. As previously mentioned the problem with the Star method is that it is not actually designed for RS485 but generally works okay if you follow the previous notes on getting the 120ohm resistor setting right, as per the previous notes.

One way that takes the guesswork out of installing the Star method is to utilise an RS485 distributor. This has the advantage that the RS485 signal is correctly distributed to the PTZs so that they behave as expected. You can create up to 4 spurs to the PTZs and put up to 4 PTZs on each spur. Just like the Daisy chain method the end dome on each spur needs to have the 120ohm resistor enabled.

Although the RS485 distributor is a small additional expense, it takes some of the guess work out of the installation design and gives a more flexible approach to cabling which itself can save time and money on the installation. Not forgetting you get more predictable results! The RS485 distributor (PTZ750) amplifies the RS485 control signal and distributes it evenly to 4 separate spurs, each spur can have up to 4 PTZs. This means that you could theoretically have up to 4 individual spurs of over 1000mtrs each to control up to 16 PTZs in total. Ideally you would put just one PTZ on each spur from the PTZ750 but up to 4 PTZs are generally acceptable. The following diagram shows a typical use of the PTZ750 RS485 distributor.

In the following example and diagram, domes 1,4,5 and 7 are at the end of each spur and therefore require the 120ohm resistor enabling by moving the jumper setting within the domes. Domes 2,3 and 6 are all “midway” in each spur and do not need the 120ohm resistor and can be left as default. The PTZ750 itself has four 120ohm resistors built in as shown and you do not have to do anything with the PTZ750 as the resistors are permanently connected within it.

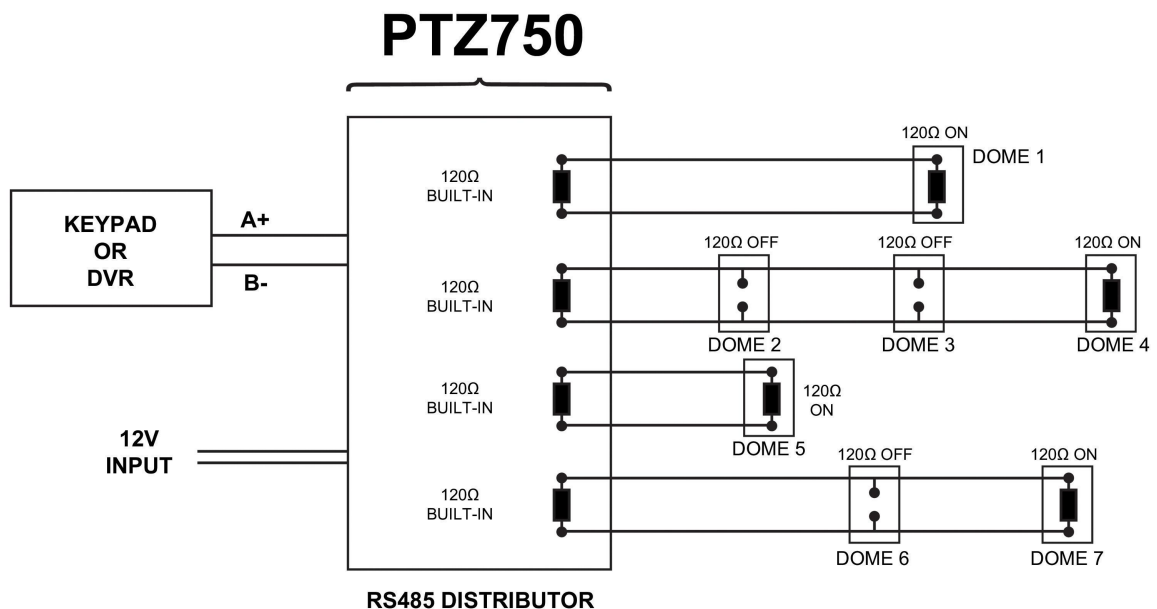

(Diagram showing how to use an RS485 distributor to improve PTZ control reliability)

Please note if you have the PTZ750 located within 5mtrs of the keypad or DVR you can connect up to 3 of them in parallel.

Setting up the Traditional PTZ Camera

1. Connection of the System

There are many ways to wire up a PTZ system.

If you have read the introduction at the beginning of these instructions you should have got a good idea what your options are.

Below is a general schematic diagram showing you some of these options.

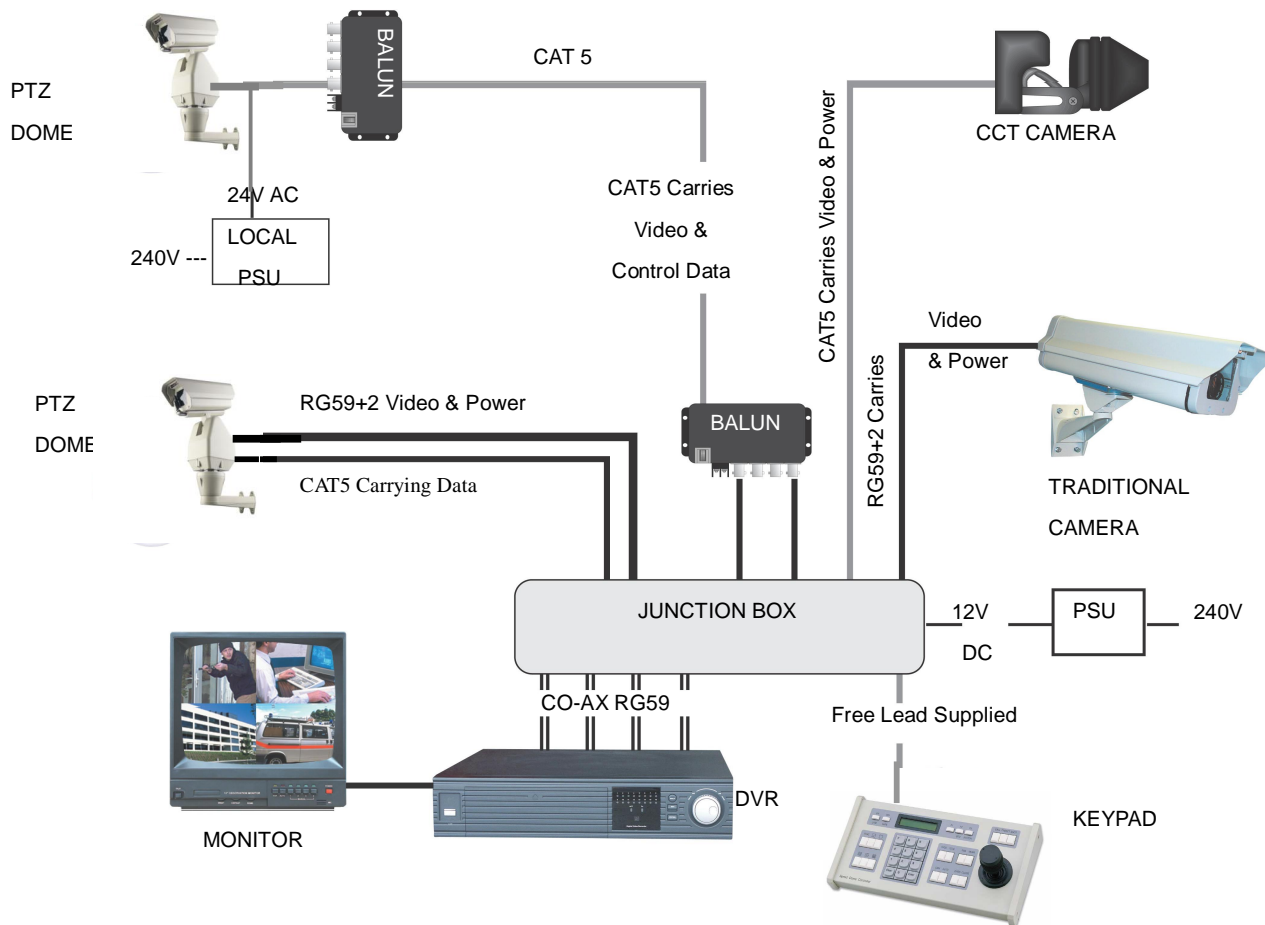

Powering the PTZs-

All the PTZs will need power. For this PTZ it is a 24V A.C power supply. The power supply must be capable of delivering at least 2.9Amps per unit.

You can either power each PTZ with its own PSU locally to it or have the PSU's remotely situated perhaps near the keyboard or DVR. The PTZ draws about 70 watts so you must take this into consideration when working out maximum cable runs.

Please note - The PTZ's heater doesn't come on until it senses the temperature drops below 0 degrees Celsius. At this point the PTZ will need up to 2.9A @ 24V A.C to operate. Please make sure that you have a sufficient power supply and cable installed to cope with this. Obviously the PTZ may work okay in the summer but

when winter kicks in and the PTZ's current draw jumps to 2.9A, an inadequate power supply or a cable with too much voltage drop may stop the PTZ from working properly. When winter comes don't be suddenly caught off guard when your customer rings you to say the PTZ has suddenly packed in because it's gone cold!!

A popular way to power the PTZ is using our COMPOSITE VIDEO cable (or shotgun as its also known) as this cable can carry the power to the PTZ and the video signal back to the monitor or DVR.

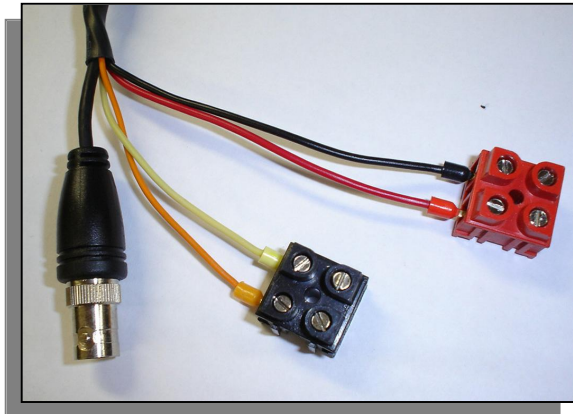

The power connection

The RED & BLACK cable coming out of the dome connected to the RED terminal block are for power. Connect a suitable 24V A.C power supply to this pair of cores.

The BNC connector is the "VIDEO-OUT" from the camera and goes to the monitor or "VIDEO-IN" of a DVR camera input.

The Orange and Yellow pair of cores that go into the BLACK terminal block are the data cables. These are the cores that carry the RS485 control signal to the dome from either the keyboard or the DVR. The next section of the instructions gives more detail on how to connect the RS485 data. Please also read the RS485 WIRING METHODS & TIPS section towards the beginning of these instructions.

The following table gives you an indication of the maximum lengths that you can achieve using this cable the composite cable and the PTZ800 range PTZs.

Power cable requirement – Assuming a starting voltage of 24V A.C is applied at the PSU end.

Composite cable	Heater OFF	Heater ON
Maximum run	80mtr	70mtr

The distances are relatively short due to the high load of the PTZ when it starts up. If the voltage of the PTZ drops below around 20V A.C it will fail to initialize. Obviously you can power the PTZs locally if you wish.

RS485 connection - *Connecting the Keypad or DVR to the PTZ.*



The PTZ is controlled by an RS485 data signal that is given by either a KEYPAD or a suitable DVR. This data signal tells the PTZ to pan, tilt, zoom etc. Its important that you read the early section of these instructions to understand the fundamental principle of RS485 cabling techniques so that you get it right.

RS485 has two cores, A and B or sometimes known as RS485 + (A) and RS485 – (B) if you get these two the wrong way around then you will not be able to control the PTZ. Sometimes installers get the connections right on one PTZ but not on the other and find only one PTZ works. They then swap the wires around at the keyboard only to find out one PTZ has now burst in to life and the other one now failed!! But they don't put 2 + 2 together and realise their mistake that they have wired one PTZ different to the other. Take great care getting these the right way around and make sure you wire each PTZ IDENTICALLY so that if you have to swap the A & B lines over at the keyboard you know all PTZs are wired the same!!

The PTZ800 series adopts the following RS485 convention:

ORANGE = RS485 + or A
 YELLOW = RS485 - or B

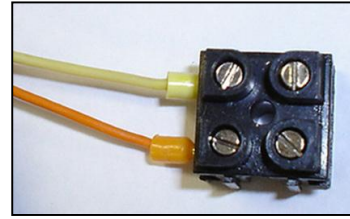

You should initially be wiring the dome to the keyboard or DVR on your workshop bench or at least your kitchen table to prove you know how to get everything to work. Once you have done this, it is just a job of extending the cables and physically installing the PTZs on site. You must obviously take note of the RS485 wiring techniques mentioned at the beginning of these instructions and get the 120ohm resistors correct in the “End of line” PTZs. Generally speaking you will always be extending the RS485 signal from either the keypad or the PTZ using a CAT5 or similar cable. **Note that data cables do not need to be connected through baluns.**

The PTZ730 and PTZ700 are two keypads that can be used with the PTZ800 series. On the rear of the keypads you will see the RS485 connections. Ensure they are connected correctly i.e the RS485 + A line and the RS485 - B line. Note that both these keypads need to be set to the same protocol as the PTZ dome. Refer to the relevant keypad instruction manuals on the keypad dipswitch settings.

PTZ730 keypad

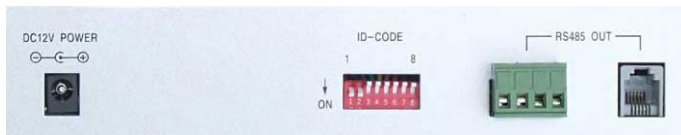

Rear of PTZ730



RS485 connections

PTZ700 keypad



Rear of PTZ700



RS485 connections

If you use cores from two different pairs in the CAT5 cable you will not get the benefit of the shielding effect of the cable twists and the PTZ will function erratically. You must always use a core from a PAIR, not two cores from two different pairs!!

Connecting the video out of the PTZ

The PTZ has a short BNC lead attached to it, this is the lead that carries the video signal from the built-in camera. You need to extend this lead to the “VIDEO-IN” of the DVR or monitor. Use a good quality RG59 coax cable or similar to do this.

TIP – If you can’t get a picture at the remote end you could always take your test monitor to your PTZ and check the picture quality on its own short BNC lead.

If you’re testing the equipment on a workbench you now have a one PTZ system.

For setting up the keyboard and testing the PTZ please read sections on default PTZ settings and using the keyboard.

You can use a keyboard or a suitable DVR to control the PTZ. A suitable DVR would be one with PTZ functionality built into it and preferably Pelco-D protocol. If your DVR has a list of protocols it’s always best to try “Pelco-D” first or “JEC” protocol, as these are very widely available. In the DVR, with either Pelco-D or JEC set, you must also make sure you set up the “baud-rate” to 2400. JEC protocol is very similar to Pelco-D but has a wider tolerance.

A typical site installation would look like the following diagram on the next page.

It shows the PTZ connected to the keypad plus how the PTZ could also be connected to a DVR instead of the keypad or at the same time. DVR’s that have the capabilities of PTZ control will have a terminal or connection on them somewhere, where the PTZ’s RS485- A and RS485- B line can connect to. Please refer to the individual DVR instructions of how to do this.

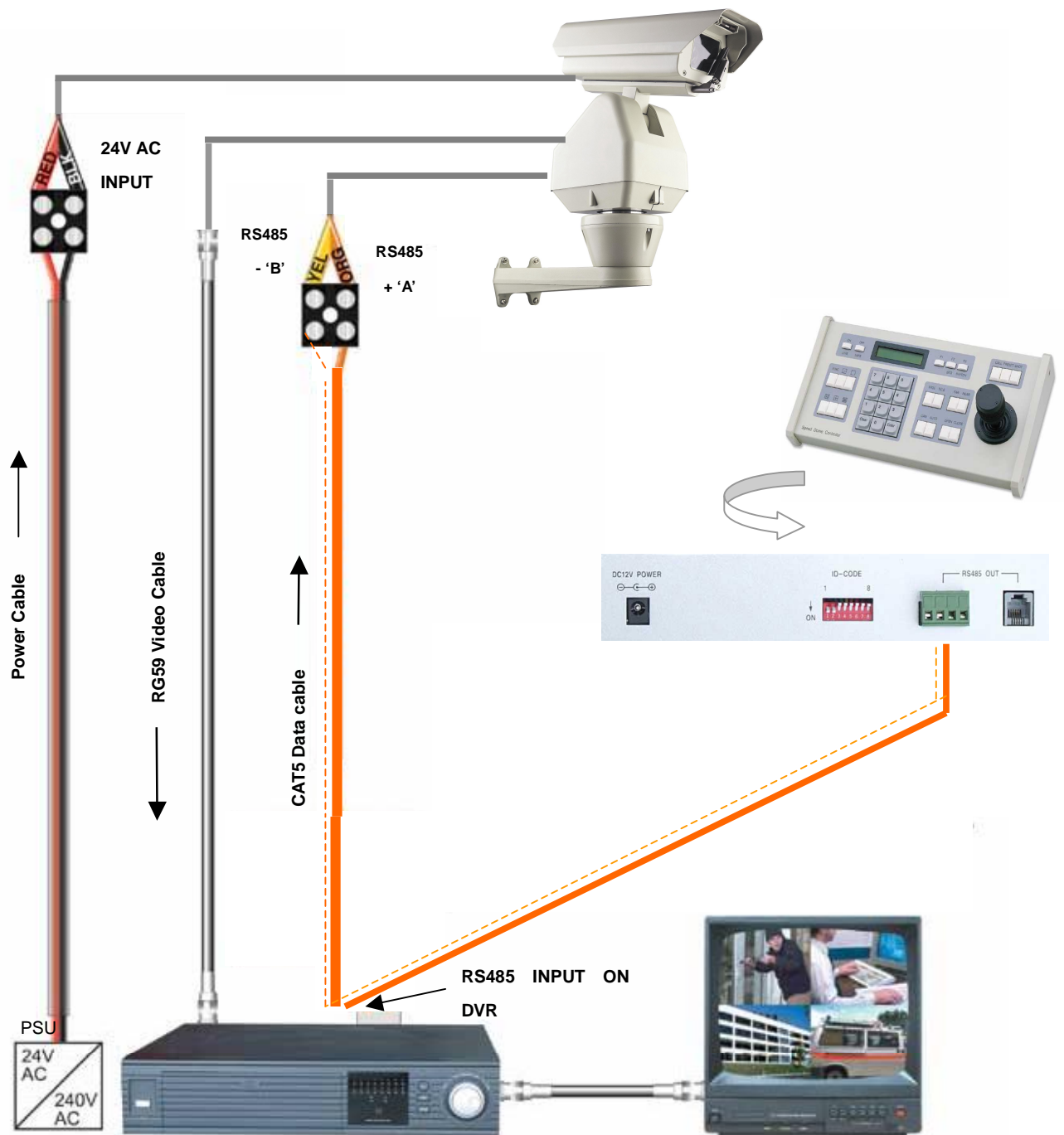

If you're using more than one PTZ on a site

Each PTZ has a unique "address" so that if you are using more than one on a site the keyboard "talks" to the right PTZ when you want it to pan, tilt or zoom. If you only have the one PTZ on the site then the default "address" of "1" is okay and you have no reason to change the PTZ from this.

With multiple PTZ sites you need to set up each PTZ address separately.

The following diagram shows the switch options.

SW2 sets up the protocol. This switch is dealt with later in these instructions.

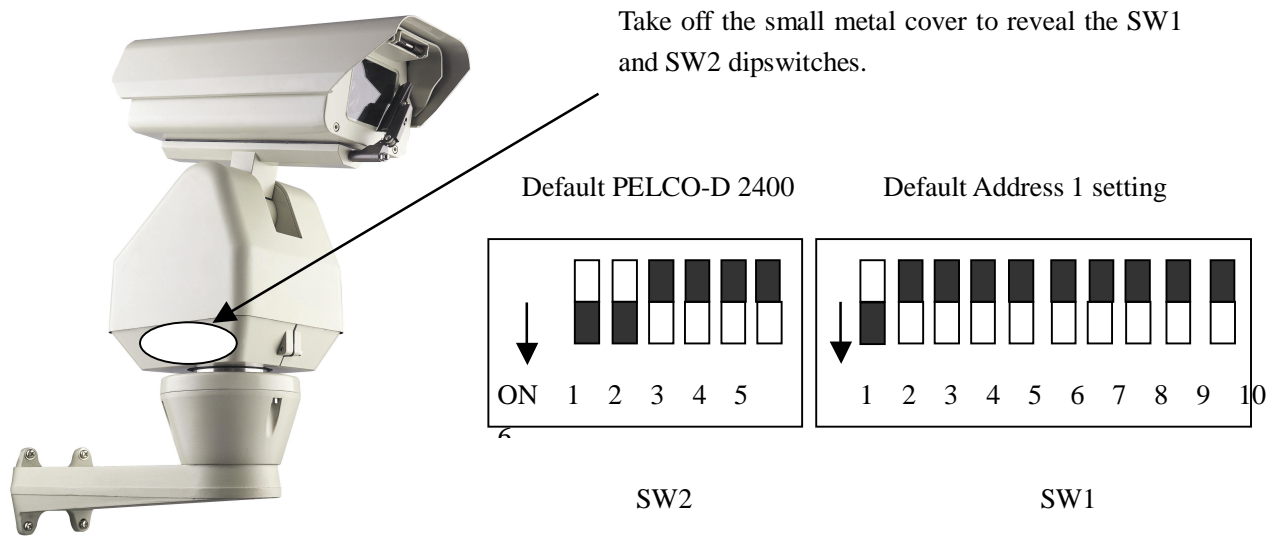

SW1 ADDRESS DIPSWITCH

The following table indicates how this is done.

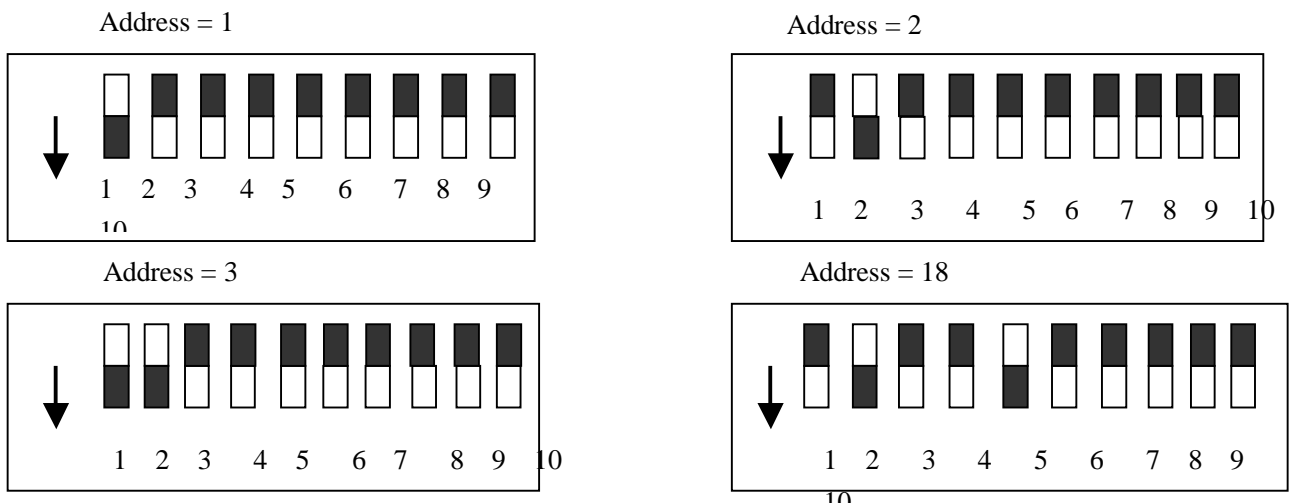

Dome Address	ID-CODE Status									
	DIP-1	DIP-2	DIP-3	DIP-4	DIP-5	DIP-6	DIP-7	DIP-8	DIP-9	DIP-10
1	ON	OFF	OFF	OFF	OFF	OFF	OFF	OFF	OFF	OFF
2	OFF	ON	OFF	OFF	OFF	OFF	OFF	OFF	OFF	OFF
3	ON	ON	OFF	OFF	OFF	OFF	OFF	OFF	OFF	OFF
4	OFF	OFF	ON	OFF	OFF	OFF	OFF	OFF	OFF	OFF
5	ON	OFF	ON	OFF	OFF	OFF	OFF	OFF	OFF	OFF
6	OFF	ON	ON	OFF	OFF	OFF	OFF	OFF	OFF	OFF
7	ON	ON	ON	OFF	OFF	OFF	OFF	OFF	OFF	OFF
8	OFF	OFF	OFF	ON	OFF	OFF	OFF	OFF	OFF	OFF
9	ON	OFF	OFF	ON	OFF	OFF	OFF	OFF	OFF	OFF
10	OFF	ON	OFF	ON	OFF	OFF	OFF	OFF	OFF	OFF
11	ON	ON	OFF	ON	OFF	OFF	OFF	OFF	OFF	OFF
12	OFF	OFF	ON	ON	OFF	OFF	OFF	OFF	OFF	OFF
13	ON	OFF	ON	ON	OFF	OFF	OFF	OFF	OFF	OFF
14	OFF	ON	ON	ON	OFF	OFF	OFF	OFF	OFF	OFF
15	ON	ON	ON	ON	OFF	OFF	OFF	OFF	OFF	OFF
16	OFF	OFF	OFF	OFF	ON	OFF	OFF	OFF	OFF	OFF
17	ON	OFF	OFF	OFF	ON	OFF	OFF	OFF	OFF	OFF
18	OFF	ON	OFF	OFF	ON	OFF	OFF	OFF	OFF	OFF
...
1023	ON	ON	ON	ON	ON	ON	ON	ON	ON	ON

Table 1

2. Setup of the Protocol and the Default Baud Rate.

As shown in Table 2, SW2 is used to set the protocol of communication and the baud rate used by the dome camera. DIP-4 to DIP-1 of SW2 is used to select protocols and a maximum of 16 different protocols can be selected. Pelco-D 2400 is used for most System Q equipment.

Protocols	DIP status				Normal Baud Rate	
	DIP-1	DIP-2	DIP-3	DIP-4	DIP-5	DIP-6
SAMSUNG	ON	OFF	OFF	OFF	OFF	ON
B01	ON	OFF	OFF	OFF	OFF	ON
NEON	ON	OFF	OFF	OFF	OFF	ON
Santachi	OFF	ON	OFF	OFF	OFF	ON
PELCO-D	ON	ON	OFF	OFF	OFF	OFF
PELCO-P/4800	OFF	OFF	ON	OFF	ON	OFF
PELCO-P/9600					OFF	ON
PANASONIC	ON	OFF	ON	OFF	OFF	ON
Longcomity	OFF	ON	ON	OFF	OFF	ON
HUNDA600	ON	ON	ON	OFF	OFF	ON
LILIN	OFF	OFF	OFF	ON	OFF	ON
VICON	ON	OFF	OFF	ON	ON	OFF
MOLYNX	OFF	ON	OFF	ON	OFF	ON
KALATEL	ON	ON	OFF	ON	ON	OFF
VCL	OFF	OFF	ON	ON	OFF	ON
Reserved	ON	OFF	ON	ON	OFF	ON
ALEC	OFF	ON	ON	ON	OFF	ON
Ultrak	ON	ON	ON	ON	OFF	ON

Some protocols and the states of the coding switches of normal baud rates of these protocols are shown as follows:

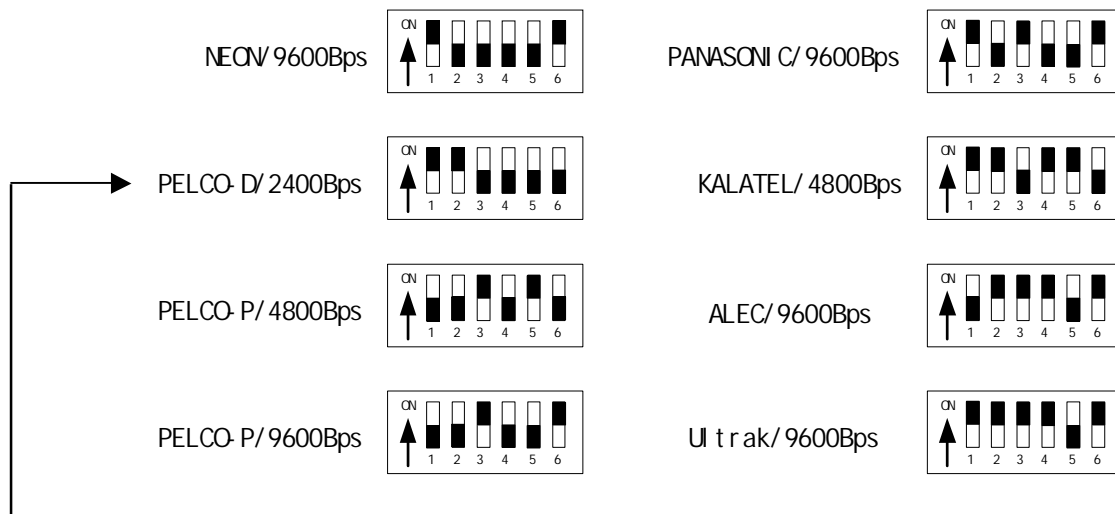

Special Note: The SW2 dipswitch settings for the above example protocols may be inverted. The black squares represent the actual dipswitches. Ensure that you check the position of the ON position before making the switch changes. This PTZ is shipped with settings for the PELCO-D protocol at 2400 BPS.

Setup of the Baud Rate of Communication.

As shown in Figure 2, SW2 is used to set the protocol of communication and the baud rate used by the PTZ. DIP-5 and DIP-6 of SW2 are used to select the baud rate of communication and 4 different baud rates can be selected in maximum. If the controller adopts a non-standard baud rate, you can adjust it to be identical with that of the controller, as per the following table.

Baud Rate of Communication	DIP-1	DIP-2	DIP-3	DIP-4	Setup of Baud Rate	
					DIP-5	DIP-6
2400bps					OFF	OFF
4800bps					ON	OFF
9600bps					OFF	ON
19200bps					ON	ON

Using the PTZ730 keypad with the Traditional PTZ series



PTZ730 keypad

NOTE 1: For more detailed instructions in setting up the keypad or using one of our other keypads, please refer to the instruction manual supplied with the product.

NOTE 2: The PTZ730 keypad requires you to press the function key first followed by the value e.g <CAM> **01** <Enter> whereas some keypads e.g PTZ700 require the value first, then the function e.g **01** <CAM> <Enter>

When you first take the keyboard out of the box you will need to set it up for the PTZs that you are using.

The PTZ you have purchased has the default settings of; PELCO-D 2400-BAUD rate Address 1

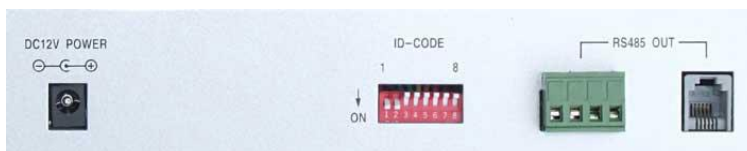

Rear of PTZ730 keypad

First read through the keypad instruction manual supplied. Set the protocol and baud rate in the keypad using the dipswitches on the rear of the unit. Note that all PTZs controlled by this keypad must have identical protocol and baud rate settings. The manual supplied with the keypad will show you what these settings should be.

Next connect the RS485 connections from the PTZ ensuring that the A and B lines are connected correctly.

Finally connect the power supply. Both the PTZ730 and PTZ700 keypads require a 12V DC PSU (500mA minimum). It is recommended to use a POW800 for this purpose. Now press the keypad ON button.

Select a PTZ camera by pressing CAM button followed by camera address and Enter*. The LCD display will indicate the camera channel selected. CAM 01 indicates that the keyboard is ready to talk to camera with address 1, if you have another PTZ set at camera address 2, press CAM button followed by 02 and Enter. This would change the display screen to CAM 02.

If you have multiple PTZs you will need to change the address of each PTZ so they are different but PLEASE LEAVE THE PTZs ON PELCO-D 2400 BAUD RATE.

* see NOTE 2 above.

PRESETS and other functions.

The PTZ has up to 128 presets that once programmed with stay in the PTZ's non-volatile memory so they will be retained even after a power cut.

What is a preset? A preset is a particular area or object that the PTZ was looking at and has been stored into its memory so when the preset is "called-up" the PTZ will select the area again without the operator using the joystick to do this. Even the zoom at the time is stored into the preset. This means that you could for example store a PRESET of a car-park entrance. When the operator calls up this preset the camera automatically zooms in on this area. By storing more than one preset you can add even more functionality to the PTZ. By having two presets, you can then get the PTZ to "SCAN" between the two locations. You can even vary the speed of this scan.

Having 3 or more presets you can get the PTZ to go on a TOUR (PATROL) of the presets. When you run the patrol the PTZ goes to one preset, then waits a short period then on to the next preset and so on. The PTZ continues to cycle around this patrol until you cancel it. The length of time the camera stays at one location and the speed of travel between each preset point can be set in the menu.

PRESETS -How to set up a preset

Aim the PTZ where you want it to look, zoom in or out to get the correct scene and let the camera auto focus. Now press the following keys on the keypad : <PRESET> + **xx** + <Enter> (where **xx** is the preset number you wish to store). For example <PRESET> **01** <Enter> **would store PRESET 01 and the camera would always go to this location when 01 is <CALLED>.**

To test if the preset is stored correctly use the joystick to move the camera to point in a new location. Now press <CALL> **01** <Enter> (where **xx** is the preset you wish the camera to go to). In this example if you press <CALL> **01** <Enter> the PTZ should go straight to the PRESET 01 location.

TIP -You may wish to write down a list of presets that you have stored next to the keypad for the operator.

CALLING a preset

This may be as follows;

PRESET 01 = MAIN GATE (a long zoom shot)

PRESET 02 = ENTRANCE DOOR

PRESET 03 = FIRE ESCAPE

PRESET 04 = EMERGENCY EXIT

PRESET 05 = CAR PARK (zoomed-out wide angle)

PRESET 06 = CAR PARK (zoomed-in narrow angle)

When the operator wishes to quickly zoom in on the MAIN GATE all he has to do is press <CALL> **01**<Enter>. To go to the EMERGENCY EXIT he would press <CALL> **04** <Enter> and so on.

To call up any previously stored preset camera location, simply press <CALL> **xx** <Enter>, where **xx** is the preset number.

Patrols (Tours) – How to set them up and use them

A patrol (tour) is simply a collection of at least three preset camera locations that are run in sequence with the PTZ stopping at each location for a brief period of time and then moving on to the next preset.

For example, you could use a patrol so that an outside PTZ camera points at a gate, then at a side doorway, then zooms out to get an overall shot of a car park and finally zooming in on a delivery bay, before repeating the whole cycle again. Patrols can be useful for both outside and internal PTZ's. For a shop they could be used to cover key areas like clothes rails, tills and changing rooms in a sequence.

To set up a patrol you need to set up the individual stop points where the camera will pause. These are called *presets*.

An example four preset mini-tour

Setting the presets using the keypad

STEP 1- Using the keypad joystick, move to where you wish to start the tour and then press **<PRESET> 01<Enter>**

STEP 2- Now move to the next location and press **<PRESET> 02 <Enter>**

STEP 3- Now move to the third location and press **<PRESET> 03 <Enter>**

STEP 4- Finally move to where you wish to end the tour and press **<PRESET> 04 <Enter>**

Deleting a preset

You may wish to delete a preset.

To do this press **<PRESET> xx <Enter>** holding the preset button down for 3 seconds at the end.
(xx = preset number).

For example to delete preset 1, press **<PRESET> 01 <Enter>** (holding the preset button for 3 seconds)

Obviously if you wish to overwrite a preset with a new location, simply aim the camera at the new location and store the preset as normal, this will simply overwrite the old preset.

Setting the Patrol (Tour)

To setup the patrol/tour you need to enter the Advanced Menu System by selecting **<CALL> 95 <Enter>** on the keypad. You will see the **Main Menu** displayed on the screen. The main menu can also be opened by calling preset 1 twice within 4 seconds.

Using the joystick up/down direction movement, select the **PROGRAM** menu.

Use the joystick pan right movement to enter this menu.

Now use the Joystick up/down direction movement to select **SET PATROL**. To the right of this, is the patrol sequence number. By moving the Joystick to the right this number can be increased from 1 ~ 6 (up to six patrols/tours can be programmed) or decreased using the left direction movement. Start with sequence **01**.

Now press the **OPEN** button to select edit mode. A table will be displayed showing 16 patrol item numbers. Note that the screen is divided into two halves with two patrol positions per line. Only the odd patrol item numbers are identified down the left hand side of the display. In the bottom left hand corner the patrol sequence number is displayed. This can be 01 ~ 06.

In the example we are setting four presets in the first patrol sequence.

To edit a patrol sequence

NO Patrol Item No.
POS No. of Preset Position
SP Dome speed (0, 1~8)
 0 and 1 are fastest speed –
 8 is slowest speed
TM Dwell time at this position
 Time 0 ~ 99 seconds

NO	POS	SP	TM	POS	SP	TM
01	001		01	01	002	01
01						
03	003	01	01	004	01	01
05	---	--	--	---	--	--
07	---	--	--	---	--	--
09	---	--	--	---	--	--
11	---	--	--	---	--	--
13	---	--	--	---	--	--
15	---	--	--	---	--	--
SEQ:01				CLOSE.EXIT		

SEQ:nn The Patrol number. (01 ~ 06)

Special Note: The patrol item number (**NO**) is an ascending number list of the preset items within this sequence. It may not necessarily reflect the actual preset number. You could for instance have preset item (NO) 01 with preset position 004 as the first preset required.

Enter the preset position number (**POS**), the dome speed (**SP**) and the dwell time (**TM**) for each preset by using the Joystick up/down movement. Move the Joystick to the right to move to the next field.

After including all the presets required in this patrol/tour, press the Keypad **CLOSE** button to exit. If you add extra presets later and wish to incorporate into a patrol/tour already created, you must add the additional preset positions in the necessary SET PATROL table sequence.

Now exit the menu by moving the Joystick down, selecting **EXIT** and then moving the Joystick to the right to return to the Main Menu. Again use the Joystick to select **EXIT** and exit the Advanced Menu System by selecting the right pan movement.

Calling the Patrol (Tour)

There are two methods of initiating the patrol or tour. If you enter <CALL> **91** <Enter> via the keypad you can initiate patrol/tour sequence 1 only.

You may also initiate a patrol or tour through the Advanced Menu System.
Enter <CALL> **95** <Enter> on the keypad.

You will then see the **Main Menu** displayed on the screen.

Using the joystick up/down direction movement, select the **PROGRAM** menu.
Use the joystick pan right movement to enter this menu.

Now use the Joystick up/down direction movement to select **RUN PATROL**. To the right of this, is the patrol sequence number (**xx**). By moving the Joystick to the right this number can be increased from 1 ~ 6 (up to six patrols/tours can be programmed) or decreased using the left direction movement. Now press the **OPEN** button to initiate the patrol/tour sequence number.

Special Note: If you notice that some expected presets are not being incorporated in a patrol/tour, check that the SET PATROL table has been setup correctly and shows all presets for the required sequence. A full explanation of the values to be set can be found in the Advanced Menu settings under PROGRAM, SET PATROL and RUN PATROL.

TIP - To stop the PATROL just move the joystick slightly.

AUTO SCAN- How to set it up

Auto-scan scans between two points. These are not presets as per the patrol(tour) facility but auto scan selection points. You may program only one auto scan.

STEP 1 – Select the required camera by pressing the <**CAM**> button and then entering <camera address> on the keypad.

Position the camera where you wish to start scanning from. To setup the Auto Scan you need to enter the Advanced Menu System by selecting <**CALL**> **95** <**Enter**> on the keypad.

You will see the **Main Menu** displayed on the screen.

Using the joystick up/down direction movement, select the **PROGRAM** menu.
Use the joystick pan right movement to enter this menu.

In the **PROGRAM** menu select **AUTO PAN START POS** followed by pressing **CLOSE** button to save.

STEP 2 - Aim the camera where you wish to end the scanning point. Now select the **PROGRAM** menu **AUTO PAN END POS**, followed by **CLOSE** button to save.

Calling the Auto Scan

First you must set the start and end positions of the auto scan as above. This runs the auto scan function between these two points. There are two methods of initiating the auto scan. If you enter < **CALL**> **97** <**Enter**> via the keypad you can initiate the auto scan. Note that the **CALL 97** will run at the speed set in the **RUN AUTO PAN** table.

You may also initiate the auto scan through the Advanced Menu System. Enter the Main Menu by selecting <**CALL**> **95** <**Enter**> on the keypad.

You will see the **Main Menu** displayed on the screen.

Using the joystick up/down direction movement, select the **PROGRAM** menu.
Use the joystick pan right movement to enter this menu.

In the **PROGRAM** menu select **RUN AUTO PAN <speed>**. The speed is selected using the Joystick pan left or pan right. The following speed selection can be made: **FAST / NORMAL / SLOW / -FAST / -NORMAL / -SLOW**. There are 6 speed selections. The first three relate to scans up to 180° and the second three relate to scans greater than 180°. If the start position is the same as the end position it will do a 360° scan. Now press the **CLOSE** button to save and initiate the Auto Scan.

TIP - To stop the scan just move the joystick slightly.

RECORD PATTERN- What is a record pattern

This PTZ has an option to store a record pattern. A record pattern consists of a continuous sequence of standard pan and tilt movements or lens commands recorded within a 40 second interval. A record pattern does not use presets. You can limit movement at a required position and pan and tilt within the 40 second time restriction. Once the recording is complete, i.e you have closed the recording or the record time has expired, you may use an option in the Advanced Menu System to replay the recorded pattern. Once this recorded pattern is initiated, the PTZ will run the record pattern continuously until a keypad movement is detected or an alarm is activated.

RECORD PATTERN- What is the difference between a pattern & a patrol (tour)

A patrol (tour) uses presets and when initiated, the PTZ will move to a maximum of 16 preset positions using the speed attribute and the dwell times as set in the Program Patrol Table. The speed of PTZ movement between any two presets can be selected but this is a constant speed and not a variable speed. A patrol (tour) can run for an extensive length of time with a dwell time of a maximum of 99 seconds at each of sixteen preset positions. In addition up to six different patrols (tours) can be stored each with different preset parameters whereas only one record pattern can be recorded. When a preset is stored the PTZ stores not only the preset position but also zoom and camera attributes. A record pattern does not record zoom attributes.

A record pattern does not use presets. It however allows the user to record a continuous sequence of standard pan and tilt movements or lens commands but does not allow presets, flip, digital zoom, proportional pan or turbo speed. The record pattern sequence can be recorded using the keypad pan and tilt joystick but will only record up to a 40 second interval. A record pattern allows the user a continuous view rather than selected preset positions and is similar to an auto scan except that an auto scan only allows a selected movement speed whereas the record pattern reflects the user movements made during the recording of the record pattern.

RECORD PATTERN- How to set it up

Record Pattern allows a pattern to be recorded which consists of any standard pan and tilt or lens command within a 40 second interval. A pattern is automatically closed when the 40 second interval is exceeded or by pressing the CLOSE button. Note that the following are not allowed in a pattern: presets, flip, digital zoom, proportional pan and turbo.

STEP 1 – Select the required camera by pressing the **CAM** button and entering <camera address> followed by <Enter> on the keypad.

Position the camera where you wish to start the record pattern sequence. Enter the Advanced Menu System by selecting <CALL> **95** <Enter> on the keypad.

You will see the **Main Menu** displayed on the screen.

Using the joystick up/down direction movement, select the **PROGRAM** menu.
Use the joystick pan right movement to enter this menu.

In the PROGRAM menu select **RECORD PATTERN** followed by pressing **CLOSE** button to save.

STEP 2 – Now move the camera using the keypad joystick to record a forty second sequence and follow this by pressing the **CLOSE** button to save. The record pattern will be stored for future replay.

Running the Record Pattern

First you must have recorded a record pattern as detailed above. This runs a record pattern of up to 40 seconds duration. You can run the Record Pattern through the Advanced Menu System. Enter the Main Menu by selecting <CALL> **95** <Enter> on the keypad.

You will see the **Main Menu** displayed on the screen.

Using the joystick up/down direction movement, select the **PROGRAM** menu.
Use the joystick pan right movement to enter this menu.

In the PROGRAM menu select **RUN PATTERN**. Now press the **CLOSE** button to save and initiate the Record Pattern sequence. This will run continuously.

TIP - To stop the record pattern just move the joystick slightly.

USING THE PTZ800 ADVANCED FUNCTIONS-

On Screen Graphics (OSD) –

The PTZ800 series boasts six patrol (tour) options, an auto scan option and a record pattern option. All these can be configured using the OSD.

To bring up the camera menu press **<CALL> 95 <Enter>**.

The OSD is then displayed on the screen. You can navigate between the various options using the Joystick control – up to increase and down to decrease – right pan to enter and left pan to exit. You can also use the OPEN button to enter and the CLOSE button to save and exit.

THE ADVANCED MENU SYSTEM

Using the Advanced Menu System.

This menu system allows the user to alter the PTZ menu instruction options and settings using a control keypad. This first page shows the initial main menu page and only describes the general functions. The following pages show the main menu option selected on the left hand side of the page and a breakdown of that menu page on the right hand side of the page.

MAIN MENU

To enter the main menu system press **CALL 95 <Enter>** on the Keypad.

Use the Joystick control pan up or pan down to increase or decrease a value and pan left or pan right to enter a selection.

The OPEN button can also be used to enter a selection and the CLOSE button to exit.

To leave the main menu press EXIT in Main Menu.

MAIN MENU

1. DISPLAY SETUP
2. CAMERA SETUP
3. CONTROL SETUP
4. PROGRAM
5. CAM DEFAULT SET
6. RESET PT
7. EXIT

DESCRIPTION OF MENU OPTIONS

DISPLAY SETUP: To set dome camera address display – set position of address – set preset title – set preset title position – open camera screen.

CAMERA SETUP: To set slow shutter – set backlight compensation – set low light shooting – auto/manual iris – digital zoom – auto/manual focus – white balance.

CONTROL SETUP: To set auto flip – alarm – preset freeze – set home function

PROGRAM: Set auto pan start & end – run auto pan – edit preset title – setup patrols/tours – run patrols /tours – record pattern – run pattern.

CAM DEFAULT SET: To select camera default settings.

RESET PT: To reset the PTZ camera titles.

EXIT: To exit menu.

DISPLAY SETUP

To access Display Setup press the **OPEN** button on keypad or move the Joystick to the right. The menu below will be displayed.

MAIN MENU

1. **DISPLAY SETUP**
2. CAMERA SETUP
3. CONTROL SETUP
4. PROGRAM
5. CAM DEFAULT SET
6. RESET PT
7. EXIT



DISPLAY SETUP

ID DISPLAY	ON
ID POS	TOP-L
TITLE DIS	ON
TITLE POS	01 LINE
CAM DISPLAY	ON

RETURN

DISPLAY SETUP MENU OPTIONS

ID DISPLAY ON / OFF

When set to ON the camera address of the dome appears in the screen display e.g. CAM 001.

The default setting is ON. To toggle these settings move the Joystick to the right or press the OPEN button. To return to Main Menu use the Joystick down movement to RETURN and press the OPEN button on the keypad or move the Joystick to the right.

ID POS TOP-L / TOP-R / BOTT-R / BOTT-L

This allows user to position the camera address display at one of the following corners of the display: TOP-L (Top Left), TOP-R (Top Right), BOTT-R (Bottom Right) and BOTT-L (Bottom Left). To toggle these settings move the Joystick to the right or press the OPEN button. To return to Main Menu use the Joystick down movement to RETURN and press the OPEN button on the keypad or move the Joystick to the right.

TITLE DIS ON / OFF

When this is set to ON, the title of the preset point appears in the left of display when the preset is called. E.g. NO.001 ENTRANCE. The **PROGRAM** option is used to setup the title.

To toggle the settings move the Joystick to the right or press the OPEN button. To return to Main Menu use the Joystick down movement to RETURN and press the OPEN button on the keypad or move the Joystick to the right.

TITLE POS 01~10 LINE

This is used to set the display position of the preset title. Specify line number from 01 ~10.

Line 1 is at the top of the display and line 10 at the bottom. To toggle the settings move the Joystick to the right or press the OPEN button. To return to Main Menu use the Joystick down movement to RETURN and press the OPEN button on the keypad or move the Joystick to the right.

CAM DISPLAY ON / OFF

When this is set to ON the camera screen will be opened. To toggle the settings move the Joystick to the right or press the OPEN button. To return to Main Menu use the Joystick down movement to RETURN and press the OPEN button on the keypad or move the Joystick to the right.

RETURN

To return to Main Menu move the Joystick to the left or press the OPEN button.

CAMERA SETUP

Move the Joystick down to select Camera Setup and press the OPEN button or move the Joystick to the right. The menu below will be displayed.

**MAIN MENU**

1. DISPLAY SETUP
- 2. CAMERA SETUP**
3. CONTROL SETUP
4. PROGRAM
5. CAM DEFAULT SET
6. RESET PT
7. EXIT

CAMERA SETUP

SLOWSHUTTER	AUTO
BACK LIGHT	OFF
ICR SHOT	AUTO
IRIS	AUTO
D-ZOOM	ON
FOCUS	AUTO
WB SET	ATW
MENU OF CAM	
RETURN	

NOTE: The following camera setup options depend on the camera type installed.

SLOW SHUTTER AUTO / MANU

Sets a manual shutter speed. In auto mode the electronic shutter is fixed on 1/50 sec after initialization. To toggle the settings move the Joystick to the right or press the OPEN button. To return to Main Menu use the Joystick down movement to RETURN and press the OPEN button on the keypad or move the Joystick to the right.

BACK LIGHT ON / OFF

Used to switch backlight compensation on or off. This can be used to improve image quality when the object viewed is dark or dim. This option allows the user to increase backlight compensation. To toggle the settings move the Joystick to the right or press the OPEN button. To return to Main Menu use the Joystick down movement to RETURN and press the OPEN button on the keypad or move the Joystick to the right.

ICR SHOT ON / AUTO

Low light shooting. This is used when the external brightness is extremely low. Normally the camera works in the automatic state but when the light level falls to below 1 Lux the camera can be switched to the zero luminance state. To toggle the settings move the Joystick to the right or press the OPEN button. To return to Main Menu use the Joystick down movement to RETURN and press the OPEN button on the keypad or move the Joystick to the right.

IRIS AUTO / MANU

Setup of automatic iris. To toggle the settings move the Joystick to the right or press the OPEN button. To return to Main Menu use the Joystick down movement to RETURN and press the OPEN button on the keypad or move the Joystick to the right.

D-ZOOM **ON / OFF**

Setup of digital zooming. This allows the digital zoom function to be switched on or off. To toggle the settings move the Joystick to the right or press the OPEN button. To return to Main Menu use the Joystick down movement to RETURN and press the OPEN button on the keypad or move the Joystick to the right.

FOCUS **AUTO / MANU**

Setup of automatic focus option. This allows the user to control the adjustment of the focus of the camera manually. To toggle the settings move the Joystick to the right or press the OPEN button. To return to Main Menu use the Joystick down movement to RETURN and press the OPEN button on the keypad or move the Joystick to the right.

WB SET **ATW / INDOOR / OUTDOOR / ONEPUSH / AUTO / MANU**

Setup of white balance. This setting is used when the image produces colour distortion on the screen. To toggle this setting move the Joystick to the right.

ATW	automatic trace of white balance
INDOOR	indoor white balance setting
OUTDOOR	outdoor white balance setting
ONEPUSH	single push change of white balance (touch mode)
AUTO	automatic adjustment of white balance
MANU	manual adjustment of white balance

To return to Main Menu use the Joystick down movement to RETURN and press the OPEN button on the keypad or move the Joystick to the right.

MENU OF CAM Refer to separate camera instructions

RETURN

To return to Main Menu move the Joystick to the left.

CONTROL SETUP

Move the Joystick down to select Control Setup and press the OPEN button or move the Joystick to the right. The menu below will be displayed:

MAIN MENU

1. DISPLAY SETUP
2. CAMERA SETUP
- 3. CONTROL SETUP**
4. PROGRAM
5. CAM DEFAULT SET
6. RESET PT
7. EXIT

CONTROL SETUP

WIPER	OFF
DEFROSTER	OFF
RESERVED AUX	OFF
ALARM1	ON
LINKAGE1	50
ALARM2	ON
LINKAGE2	49
HOME OPTION	
RETURN	

WIPER **ON / OFF**

This allows the setting of the rain wiper control.

DEFROSTER **ON / OFF**

This allows the setting of the defroster control.

RESERVED AUX **ON/OFF**

This is an auxiliary switch control.

ALARM1 **ON/OFF**

This sets the input alarm on channel 1. When an alarm is activated the PTZ references the parameter LINKAGE1 for the preset address to call.

LINKAGE1 **< preset number > <01 ~ 50 or 65 ~ 128>**

This is the preset to call when Alarm 1 is activated and the menu ALARM1 is switched to ON.

Do not use preset numbers 51 through to preset 60 as these are used for special instructions.

ALARM2 **ON/OFF**

This sets the input alarm on channel 2. When an alarm is activated the PTZ references the parameter LINKAGE2 for the preset address to call.

LINKAGE2 **< preset number > <01 ~ 50 or 65 ~ 128>**

This is the preset to call when Alarm 2 is activated and the menu ALARM2 is switched to ON.

Do not use preset numbers 51 through to preset 60 as these are used for special instructions.

HOME OPTION

enter HOME OPTION sub menu

To enter this option move the Joystick to the right. The submenu on the right will be displayed.

HOME OPTION	
AUTO HOME	ON / OFF
HOME POS	01 / PATROL n
DWELL TIME	06 MIN
RETURN	

AUTO HOME ON / OFF

When this is set to ON the PTZ camera will return to home if there has been no action in a period of time. This does not apply if the PTZ camera is on a tour. If no home is needed when the camera is stopped, set the option to OFF.

HOME POS 01 ~ 50 or 65 ~ 128 / PATROL n

This setting allows the user to declare a preset position as the HOME position or revert to a tour number. After an alarm has been triggered a tour can be restarted automatically. For setting a preset you will need to have previously created this preset position. To toggle this setting move the Joystick to the right. To return to Control Setup use the Joystick down movement to RETURN and press the OPEN button on the keypad or move Joystick right.

DWELL TIME 1 ~ 99

This allows the user to set the time period in minutes before returning to HOME when there has been no action. To toggle this setting move the Joystick to the right. To return to Control Setup use the Joystick down movement to RETURN and press the OPEN button on the keypad or move the Joystick to the right.

Special Note: If the PTZ is on a tour and an alarm input triggered the DWELL TIME is not effective and the PTZ will Auto Home immediately if set.

RETURN return to CONTROL SETUP menu by moving Joystick to the left.

PROGRAM

Move the Joystick down to select Program and press the OPEN button or move the Joystick to the right. The menu below will be displayed.



MAIN MENU

1. DISPLAY SETUP
2. CAMERA SETUP
3. CONTROL SETUP
4. **PROGRAM**
5. CAM DEFAULT SET
6. RESET PT
7. EXIT

PROGRAM

AUTO PAN START POS
AUTO PAN END POS
RUN AUTO PAN SLOW
SET TITLE XX
SET PATROL XX
RUN PATROL XX
RECORD PATTERN
RUN PATTERN
RETURN

AUTO PAN START POS

To set the start position of an auto scan between two points, move the camera to the start position after selecting this option using the keyboard Joystick. Then press the CLOSE button.

AUTO PAN END POS

To set the end position of an auto scan between two points, move the camera to the end position after selecting this option using the keyboard Joystick. Then press the CLOSE button.

RUN AUTO PAN FAST / NORMAL / SLOW / -FAST / -NORMAL / -SLOW

This runs the auto scan function between two points. First you must set the start and end positions of the auto scan as above. If the start position is the same as the end position it will do a 360° scan. There are 6 speed selections. The first three relate to scans up to 180° and the second three relate to scans greater than 180°. The speed is selected using the Joystick pan left or pan right and to initiate the auto scan press the OPEN button.

SET TITLE

To edit titles of preset positions. Only 63 preset titles can be edited. Select preset point number using the Joystick pan left or pan right, press OPEN button to enter **EDIT MODE** and CLOSE to exit.

EDIT PRESET POINTS

To edit title of preset point. Move cursor using the Joystick pan left or pan right and modify the title using the Joystick UP/DOWN controls. Press CLOSE button to save modifications and exit. The title can be up to 8 characters long, consisting of

PRESET NO: 01
TITLE: NO TITLE

CLOSE:EXIT

0-9, A-Z, +, - and space.

NOTE: The first character of the title must be 0-9 or A-Z.

SET PATROL

To edit data for a patrol/tour. Select sequence number of patrol by using the Joystick pan left or pan right, press OPEN button to select edit mode and edit using the up/down Joystick movement, setting the POS (preset number), the Joystick pan right to select the dome speed (SP) and the dwell time (TM) followed by the CLOSE button to save and exit.

EDIT PATROL SEQUENCE

To edit a patrol sequence

NO Patrol Item No.
POS No. of preset position
SP Dome speed (0, 1~8)
0 and 1 are fastest speed –
8 is slowest speed
TM Dwell time at this position
Time 0 ~ 99 seconds

NO	POS	SP	TM	POS	SP
01	001	01	01	002	01
01					
03	003	01	01	004	01
01					
05	---	--	--	---	--
07	---	--	--	---	--
09	---	--	--	---	--
11	---	--	--	---	--

SEQ:nn The Patrol number. (1 ~ 6)

Note that two patrol points are set on each line of this menu. The CLOSE button closes and stores the new settings. The program searches for the first --- and any data following is regarded as invalid data. In the example above the program stores four preset positions numbers 01~04. However the settable range can be from 1 to 50 and from 65 to 128. You can set up to 16 preset positions per Patrol sequence and you can have up to 6 patrol sequences.

RUN PATROL

To run a multi-point patrol select the Sequence Number of the Patrol using the Joystick pan left and pan right, and run using the OPEN button.

Special Note: If you notice that some expected presets are not being incorporated in a patrol/tour, check that the SET PATROL table has been set up correctly and shows all presets for the required sequence.

RECORD PATTERN

This option allows a pattern to be recorded which consists of any standard pan and tilt or lens command. **Presets, flip, digital zoom, proportional pan and turbo are not allowed in a pattern.** The pattern length lasts for 40 seconds maximum and returns after this period or by pressing the CLOSE button.

RUN PATTERN

This option initiates the recorded pattern. To exit the menu or stop running, move the Joystick.

RETURN Return to Main Menu.

CAM DEFAULT SET

No sub-menu option for this.

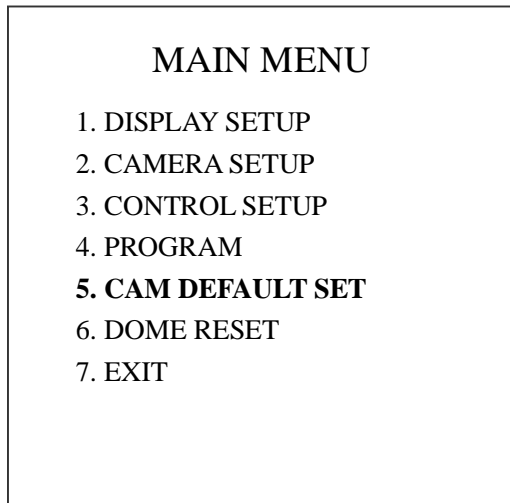

CAM DEFAULT SET

This option sets the camera default settings. Press the **CLOSE** button to exit or move down using the up and down toggle to move to the **EXIT** point.

RESET PT

MAIN MENU

1. DISPLAY SETUP
2. CAMERA SETUP
3. CONTROL SETUP
4. PROGRAM
5. CAM DEFAULT SET
- 6. RESET PT**
7. EXIT

RESET PT

This option resets the PT titles. The following display will be output

Use the Joystick left or right pan to toggle between YES and NO. Press the CLOSE button to initiate the required option.



THE OPERATION WILL
CLEAR ALL TITLES
DO YOU WANT TO
CONTINUE ?

YES NO

EXIT

MAIN MENU

1. DISPLAY SETUP
2. CAMERA SETUP
3. CONTROL SETUP
4. PROGRAM
5. CAM DEFAULT SET
6. RESET PT
7. **EXIT**

Use the Joystick to select the option and press the CLOSE button to exit menu.

Controlling one camera then another.

If you look at the image of the LCD display you can see the CAM=001 indicates that the keyboard is ready to talk to camera with address 1. In the dome the address 1 is set as default in the factory. You need to alter the DIP-switches within the domes to address 2, 3 etc if you have multiple domes on the same site, refer to the previous instructions how to set the DIP Switches. If you have another dome set at camera address 2, press CAM followed by 2. This would change the screen to CAM=002. And so on.



Special Presets

Presets 51 to 60 are used for special functions. Therefore presets 51 to 60 must not be used for patrols, alarm linkages or patrol points otherwise error conflicts will arise.

Preset	Set Preset	Call Preset
51	Wiper ON	Wiper OFF
52	Defroster ON	Defroster OFF
53	Auxiliary Output 24vAC ON	Auxiliary Output 24vAC OFF
54	Linkage of External Alarm 1 ON	Linkage of External Alarm 1 OFF
55	Linkage of External Alarm 2 ON	Linkage of External Alarm 2 OFF
56	Reserved	Reserved
57	Reserved	Reserved
58	Reserved	Reserved
59	Reserved	Reserved
60	Reserved	Reserved

Physical installation of the PTZ800

Technical Elevations

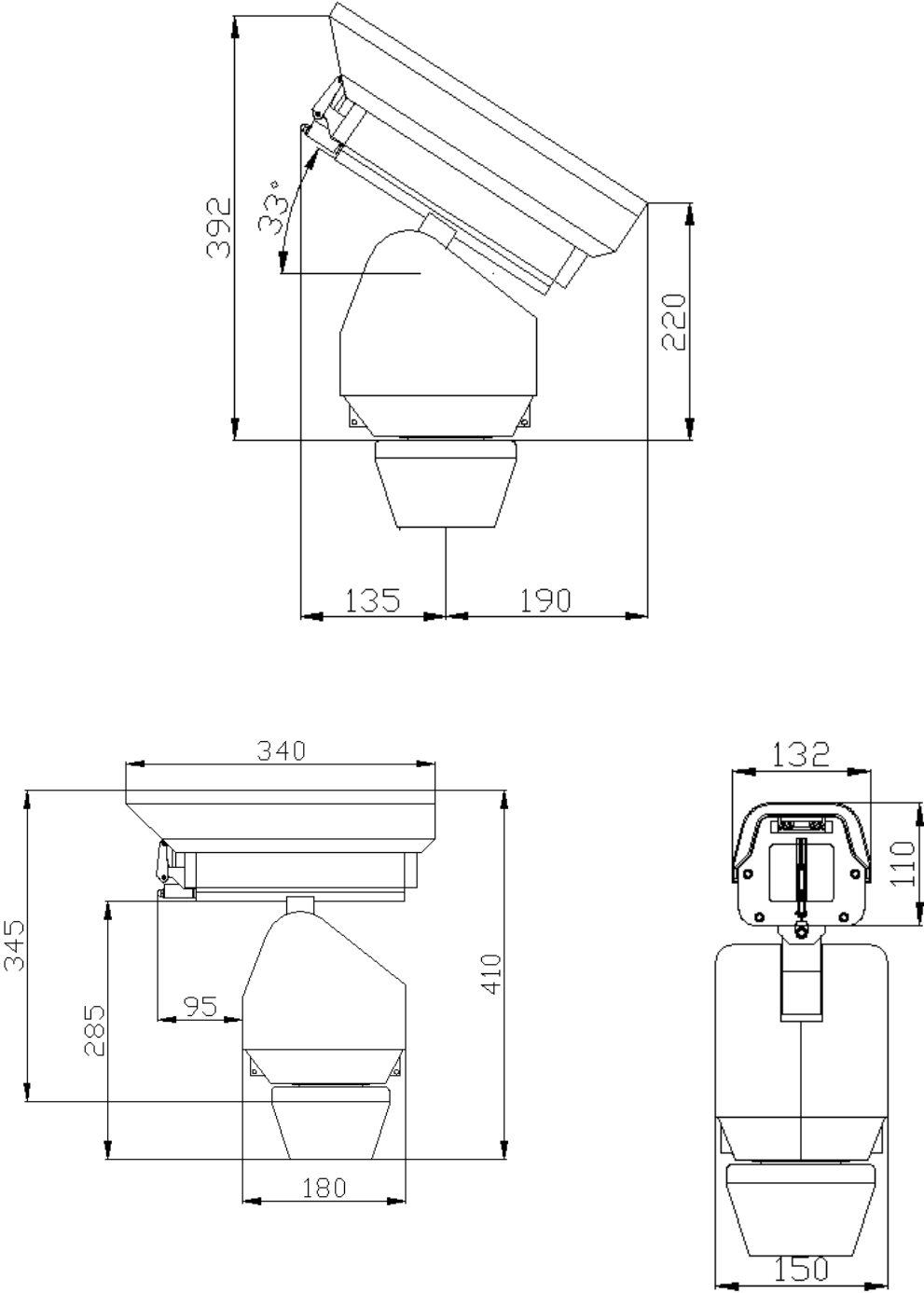

Wall Mounting

The PTZ can be fitted using the wall bracket or the base plate. If fitting using wall bracket, first secure the wall bracket using M8 screws.

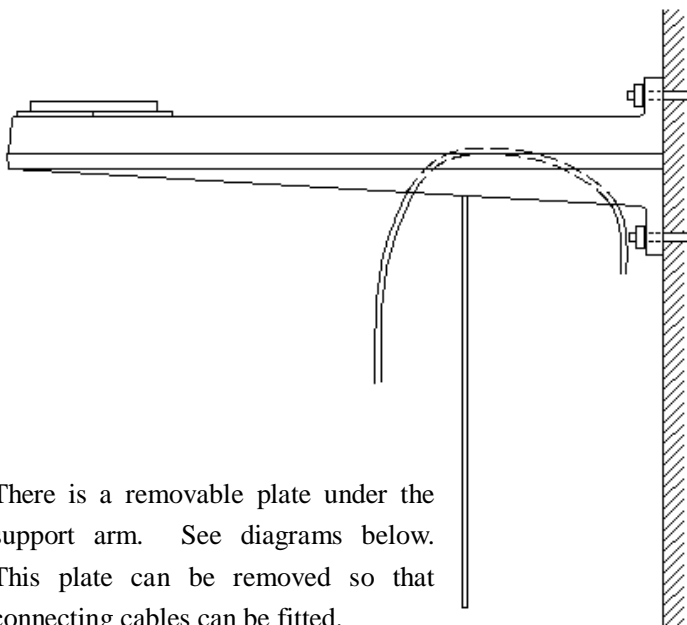

There is a removable plate under the support arm. See diagrams below. This plate can be removed so that connecting cables can be fitted.

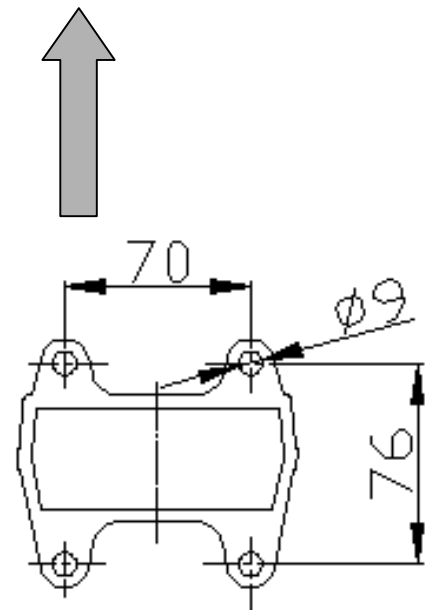

Connecting cables for wall mounting

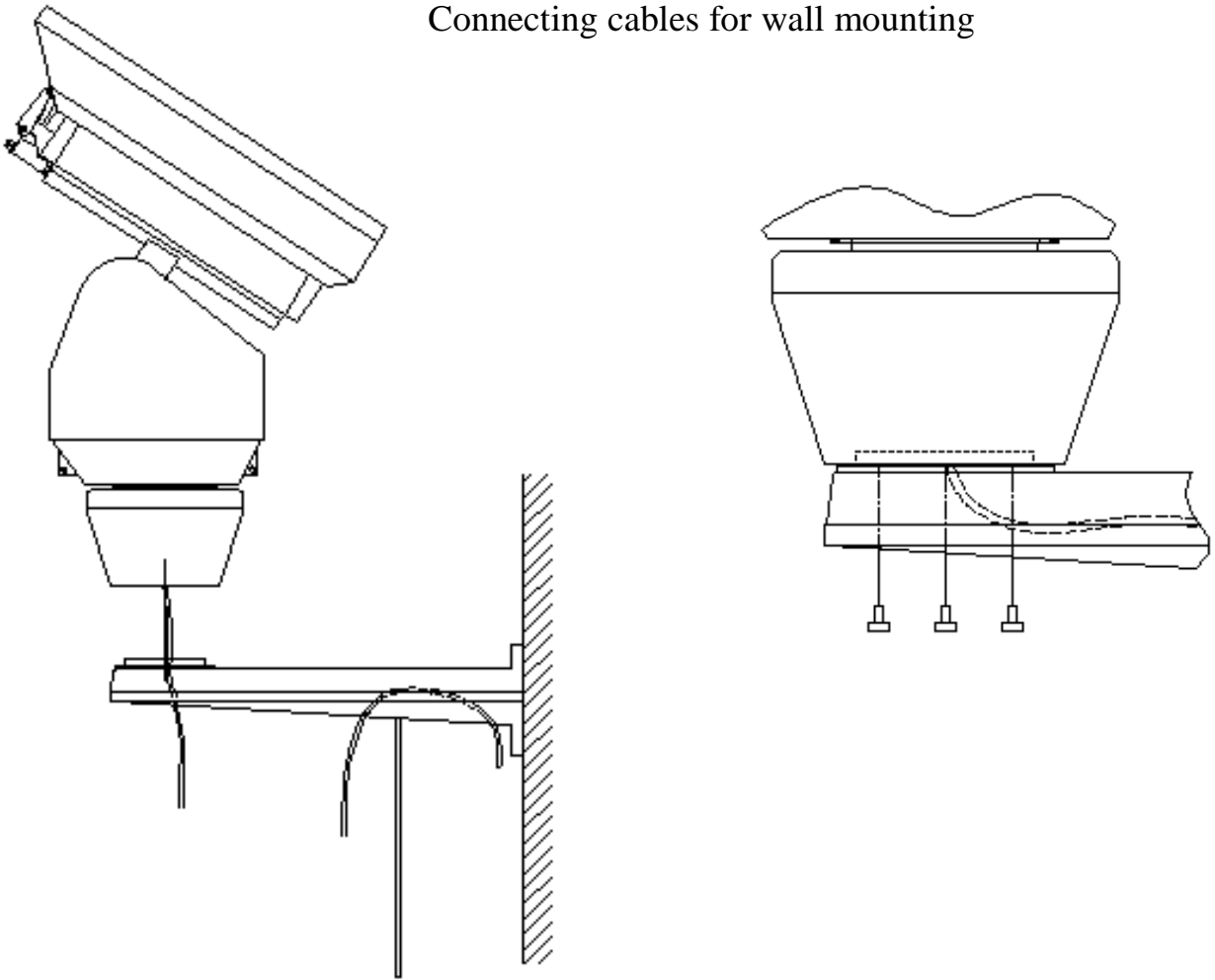

Base Plate Mounting

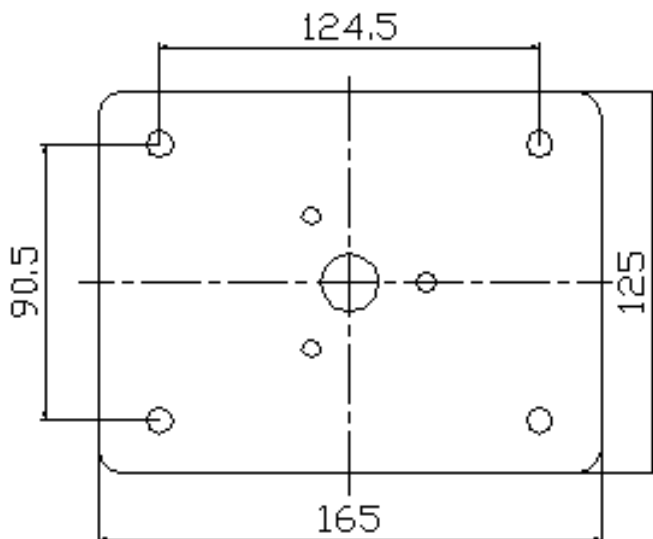

Use the base mounting plate as a template for drilling holes into fixing position. The next step is to fit the base plate to the bottom of the PTZ using M6 x 20 screws.

The third step is to fit the PTZ and base plate to the fixing position.

Ensure that the connecting wires are placed into the groove under the mounting plate to avoid them being damaged.

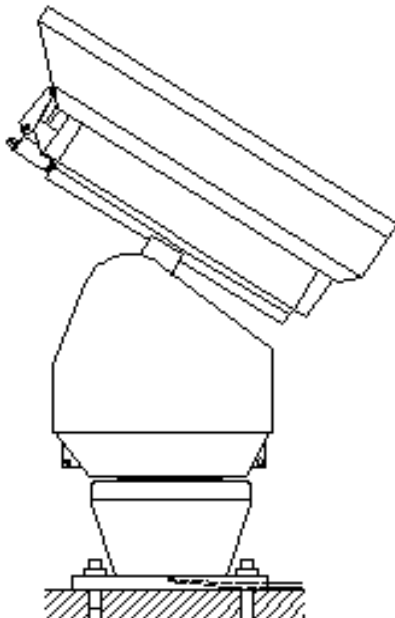
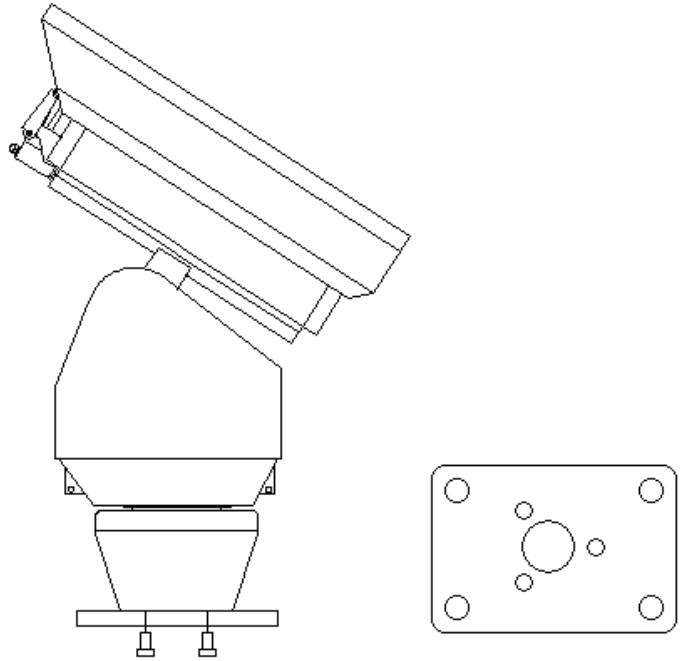

The diagram opposite show the PTZ fitted.

Wiring connections

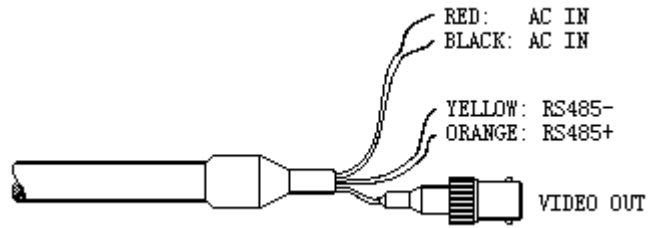

RED	Input of AC Power Supply
BLACK	Input of AC Power Supply
YELLOW	Control Wire RS485- (B)
ORANGE	Control Wire RS485+ (A)
VIDEO OUT	Video Output

Alarm connections

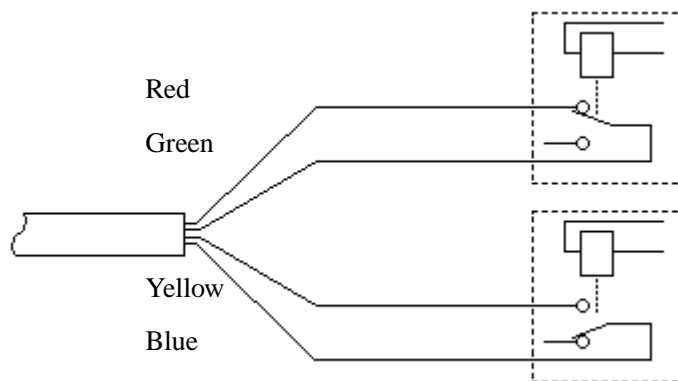

Red	Alarm Input 1
Yellow	Alarm Input 2
Green, Blue	Alarm Common Terminal

The alarm input must be a zero volt switch otherwise internal circuits could be damaged.

The alarm must be linked with the preset point, which should be set in the menu.

In case two channels are alarmed simultaneously, the pan/tilt will switch between two channels with a 2 second time delay.

If the alarm is triggered, the unit will not respond to functions such as “AUTO PAN”, “Patrol” and “Pattern” and so on.

2 channel alarm input activation

One of the special features of this dome is that it has two in-built alarm channels to call two independent presets. This means that for example you may have a door contact and when the contact is closed, it sends a 0 volt alarm switch to the PTZ on one of the two alarm channels. The PTZ will then call a previously set preset position and lock the camera onto that position. When the second alarm input channel is utilised and activated, the PTZ will switch to the second channel after two seconds. However once an alarm input channel has been activated, the PTZ will remain locked to the preset position/s and will not resume a patrol, auto scan or a record pattern until the alarm condition is cleared. However the HOME Option in the dome menu can be set to restart a tour if necessary. To set alarm activation you must first set the preset point/s from the preset range 1 through 50 or 61 through 128 in the Control Setup menu. Then switch ALARM1/2 to ON and associate the appropriate linkage1/2 parameters to the actual preset numbers stored.

Connecting the Input Alarm devices

You will need to decide if one or two alarm channels will be utilised. For each alarm channel you will need a pair of cable connections and it is recommended that a CAT5 twisted pair be utilised. Connect one core to the selected input alarm channel and the other to the ground (GND) connection. The ground is a common connection for both alarm channels. At the alarm end connect to the alarm device. This must be a 0 volt switch and maybe for example a door switch. Check that the alarm device passes a voltage free switch as any other input signal may damage the dome.

Each of the two alarm channels calls a different preset number when the 0v switch is detected by the PTZ. This allows the PTZ to move immediately to the selected preset position in an alarm condition. To set these special presets, if you have set the ALARM1 and/or ALARM2 function to ON in the Control Setup menu, now set the Linkage1 and Linkage2 parameters to reflect the presets to be used. Now move the PTZ to where you wish Alarm 1 preset to move to, and save as the preset number allocated in the associated Llinkage1 parameter. Then if you have setup alarm channel 2, move the PTZ to where you wish alarm 2 preset to move to, and save as the preset number allocated in the associated Linkage2 parameter. When two alarm channels are utilised and activated, the PTZ will respond to each alarm by calling the relevant preset and switching to the next preset after two seconds. The PTZ will lock on to the last alarm activated and will not resume a patrol, auto scan or record pattern until the alarm condition is cleared or the HOME option set in the PTZ menu to restart a tour/patrol.

Example: Connecting Alarm 1 channel to a door contact

Here is an example scenario. A company requires a PTZ to run a patrol (tour) continuously viewing four preset points. One of the preset points, preset point 3, is the main entrance door to

the building. The requirement is to ensure that during out of hours the entrance door is not breached and if the door is opened the PTZ will automatically switch to preset point 3. The PTZ alarm 1 channel is connected to a door contact on the main entrance door using a CAT5 twisted pair. This is connected at the PTZ end to the Alarm 1 and GND connection on the PTZ alarm connection lead. At the door contact end, the twisted pair is connected either way round. The PTZ is then set up for a tour using presets 01 to 04 and called TOUR 1. In addition the Alarm1 function is switched to ON and Linkage1 set to 3 in the Control Setup menu. When the building is vacated the dome is left running a tour of the four presets. If the door contact is closed a voltage free switch is made on the Alarm 1 channel. The dome then automatically calls preset 3, which locks onto the main entrance door. As the HOME OPTION menu has been set to HOME POS Tour 1, after the alarm is triggered following the closing of the door, the PTZ will automatically revert to TOUR 1. Of course if the door remains breached then the alarm condition will remain open and the PTZ will stay locked on preset point 3.

Technical data table

Power Supply	24V AC
Power Consumption	3A / 70W
Sync System	Internal/External selectable
No of Presets	128 presets
No of Patrols/Tours	6 maximum
Pattern	One pattern recording for maximum 40 second duration
Autoscan	360° programmable
Alarm Inputs	2 channels input
Alarm Outputs	None
Zoom rotation interaction	Automatic according to focal length
Auto Flip	None
Pan Speed	100° per second maximum
Pan Rotation Range	360° continuous
Tilt Range	90° maximum
Tilt Speed	40° per second maximum
Control Mode	RS485
Baud Rates	2400 / 4800 / 9600 / 19200
Fan & Heater	Fan and heater auto-start
Humidity	10% to 90% Relative Humidity
Ambient Temperature	-35°C ~ +55°C

Appendix A: General Information

Troubleshooting

1. To avoid problems and to ensure the PTZ has been correctly setup it is always advisable to test the equipment in your workshop before you go on-site. If workshop setup is successful, any problems experienced on-site will be greatly minimised.
2. Always read these instructions before you connect the equipment to any power supply and check that you are using the correct rated power supply and voltage. Never connect non-regulated power supplies.
3. If you are having problems with no video, power the PTZ and plug the video cable direct into your monitor. If still no video then check if PTZ is running the initial self test. If not check power to the PTZ, cables and connections. Remember that every PTZ is tested before despatch to you so it will be very unlikely to be a faulty PTZ unit. Note that video loss can occur on a long cable run, or loss of signal strength resulting in no video, poor quality video or even video in black and white mode. Ensure the termination jumper is correctly set in the PTZ dome head. This is accurately detailed in this instruction manual.
4. If video is okay but the telemetry is not working then check the dipswitch settings in the PTZ agree with the settings in the control unit i.e keypad or DVR. The dipswitches set the protocol, baud rate and PTZ address. Ensure that the RS485 cable connecting the PTZ to the control unit is connected the right way around.