

Mini 4 in1 PTZ Dome Range

Installation and Operation Manual

Models:

PTZM400B 10x ZOOM COLOUR BLACK

PTZM400W 10x ZOOM COLOUR WHITE



***1080p HD TVI/CVI/AHD & Analogue PTZ
Camera***

12V DC with Intelligent IRs

CONTENTS TABLE

Description	Page No.
Contents	2
Please read the following	3
Key Functions (Inc. PTZ Video Format for TVI/CVI/AHD/CVBS)	4
Technical Descriptions	5
<i>Infra-Red System, Auto RS485 Protocol/Baud Recognition</i>	
<i>Controlling the Mini 4in1 PTZ/ Setting presets using Mega DVR</i>	
Getting the PTZ up and running	7
Overview – Introduction to fitting PTZ equipment	7
Coaxitron and RS485	9
RS485 Wiring methods and Tips	9
RS485 Connection methods	10
Star method of connection	11
Setting up the PTZ camera	12
Powering the PTZs	13
RS485 connection – Connecting the keypad or DVR to the Dome	14
Connecting the video out of the PTZ	15
Using more than one PTZ on a site	15
Setting up a unique Address and Baud Rate in the PTZ	15
Using the PTZ735 keypad with the PTZM range of camera	17
Presets and other functions	18
Presets – How to setup a preset	18
Calling a preset	18
Patrols/Tours – How to set them up and use them	18
Deleting a preset	19
Setting the Patrol/Tour	19
Calling the Patrol/Tour	21
Auto Scan – how to set it up Autoscan between 2 points	21
Calling the Auto Scan	22
Record Pattern	22
Running the Record Pattern	24
Preset Function Table	24
Using the Dome’s Advanced Functions	25
The Menu System	26
The Camera Module Menu	37
System Installation	40
Alarm Feature	43
Technical Specification	44

Please read this operation manual carefully
before installing and using this unit !!!!



Please read the following;

1. Please read the operation manual carefully before installing and operating the product.
2. The **Mini 4in 1 range require a 12v DC 1.7A** power supply minimum. The rated input voltage of the camera **module** in the PTZ is 12V. Do not connect 24V AC to these cameras under any circumstances!!
3. During the course of transportation, storage and installation, the product should be handled with care avoiding vibration and any weight pressure, which may cause damage to the sophisticated optical and electronic equipment inside the machine.
4. Do not attempt to disassemble the camera. In order to prevent electric shock, do not remove screws or covers. There are no user-serviceable parts inside the camera.
5. Always use and stick to current electrical safety standards to install and use these cameras. Use a correctly rated power supply. The RS-485 and video signal cables should be kept way from other high voltage equipment such as mains cables and especially fluorescent lights. Using an anti-surge protection device is recommended to prevent damage to the PTZ camera from lightning and mains surges. Damage to units by lightning or mains voltage surges is not covered under the product warranty.
6. Do not operate in areas exceeding the stipulated limitations concerning temperature, humidity and power supply. The camera working temperature outdoor is -20°C ~ +60°C and humidity must be less than 95%.
7. Do not aim the camera directly towards the sun or an extreme light source whether it is switched on or not. Do not let the camera focus on bright and stationary objects for a long time. Doing any of these, may damage the filter on the sensor that may cause colour loss.
8. Do not use strong detergents to clean the main body of the camera as these may damage the PTZ paintwork. Wipe dirt away with a micro-fibre cloth. If needed a *mild* detergent can be used.
9. Operate the PTZ camera with care avoiding shock or vibration. If operated incorrectly, the PTZ could be damaged.
10. Ensure the PTZ is not dropped. The PTZ camera is heavy so never mount the unit on a structure that cannot support its weight.
11. When this unit is in use, avoid direct eye contact with the infrared lights.
12. The unit's outer IR transparent cover can heat up when in use and care should be taken to ensure that this PTZ is fitted where it cannot be easily touched. It must also not be fitted in close proximity to any flammable materials.

The PTZM400 range

**KEY
FUNCTIONS**

Description of Product Features

These intelligent HD-Mini 4in1 PTZ domes incorporate a high-clarity colour 10x zoom camera module. The camera module used is a 4.7mm – 47mm 2MP lens. If not using in TVI mode, please read section below called **4. PTZ Video Format**.

1. Intelligent Functionality

- a. 6 High Powered IRs are selected automatically according to the zoom setting, providing wide or narrow angle IR illumination.
- b. This Mini 4 in 1 PTZ camera supports HD modes TVI, CVI and AHD, plus CVBS (Analogue) mode. These PTZ cameras are shipped in TVI mode setting so using the AlienTVI(Coaxitron) protocol in the MEGA or MAX HD-TVI DVR allows up the coax control, alleviating the necessity for RS485 connections. If you require a keyboard to control the PTZ or the video mode is not TVI, then you will have to connect the RS485 cable. See **PTZ Video Format** below.
- c. To change the video format mode to CVI, AHD or CVBS (Analogue) mode you need to use a PTZ Call/Shot command setting. See **PTZ Video Format** below.
- d. Incorporates automatic protocol and baud rate diagnosis which means these are selected automatically for RS485 connectivity.

2. High Speed Horizontal and Vertical rotation

- a. The PTZ can pan 0 ~ 360 degrees continuously, a pan speed of 0.1° ~ 200° per second and tilts 0 ~ 90 degrees with auto flip at 0.4° ~ 30° per second.
- b. The PTZ incorporates CCVC that controls camera speed and adjusts according to lens zoom position.

3. Presets, Tours, Patterns and Auto Scan

- a. The PTZ can set up to 220 presets, each preset containing the lens zoom and angle positions.
- b. You can set up to 8 tours (Patrol Tracks) each with up to 32 presets.
- c. Can record in Mode Scan up to 4 patterns, with each pattern containing up to 100 movements.
- d. Using two preset points you can setup an Auto Scan that can run at low, medium or high speed, internally between the preset points or externally.
- e. Continuous 360°scan option available.

4. PTZ Video Format

The 4 in 1 Mini PTZ cameras can be used with video formats TVI, CVI, AHD and CVBS (Analogue). The cameras are shipped in TVI mode and can be controlled up the co-ax using the MEGA and MAX DVR coaxitron feature.

If you have one of these DVRs then you can change the video format by using the PTZ control feature and calling a preset command and value. If you do not have one of these DVRs then you will have to use an RS485 connection using a PTZ controller/keyboard.

The command is **CALL/SHOT 246 Enter + CALL/SHOT ((value) = mode) Enter**
or **246 CALL/SHOT + ((value) = mode) CALL/SHOT**
(Value = 1 for TVI, 2 for CVI, 3 for AHD and 4 for CVBS (Analogue))

Example: Change to CVBS mode ...CALL/SHOT 246 Enter + CALL/SHOT 4 Enter
or 246 CALL/SHOT + 4 CALL/SHOT

Note that if you used coaxitron to change to CVBS, you will need an RS485 connection to change it back.

5. PTZ Control

The speed is adjusted automatically according to the lens zoom range.

Technical Descriptions

Infrared System

The infrared system runs normally under automatic control. The PTZ has an automatic intelligent IR light facility that is coupled to the focus operation so that wide angle shots are given a wide diffused IR beam whilst longer distance shots are given a more powerful narrower IR beam.

Camera zooms in..... so does the built in IR light.



Camera zooms out ...so does the IR light.



The Infrared lamps illuminate in a low light condition and switch off when light levels improve. A menu default option is set to **AUTO** for **normal operation**. You may set the option to **ON to force the Infrareds to illuminate or OFF to close** but if it is required to return to normal mode the option must be set to **AUTO**.

Note that changes in the menu do not take effect until you exit from the menu.

Automatic RS485 Protocol and Baud Rate recognition

The PTZ is able to recognise the protocol and baud rate when connected to control equipment. However in the System Information menu you can enable the Soft Address (ID) which then allows you to software change the ID from the Hard Address that reflects the address of the physical ID dipswitch setting located on the dome face under the protective cover.

Controlling the Mini 4 in 1 PTZ



In order to access the PTZ menu via a keyboard 95 Call/Shot using the RS485 cable connection. If using the ALIEN DVR you can use the Coaxitron facility. Just select the camera channel display and left click to display at bottom of picture.



If you click on the  with the left mouse button or enter “95 CALL/SHOT” or “CALL/SHOT 95 ENTER” this will display the PTZ menu. See special note below.

To move up and down the menu use the up or down direction key or joystick controller. Move right to enter the selected option. To change the option press the IRIS+ button or Open which displays an ampersand to the left of the selected option.

To move the PTZ Control box if it covers the menu, left click and hold down mouse button on blue area at top of box and drag to different part of display screen.



Then use the up and down direction keys or joystick controller up or down movement, to alter the value. Then press the IRIS+ button or Open again to save the change. When all changes made, move down to Exit and press the Iris - button or Close button to exit out of menu.

Setting presets using the MEGA DVR

To set a preset point using the MEGA DVR, select the PTZ option by clicking on the Menu, then Video, then PTZ. In Preset box enter preset number. Move camera to first preset point using direction arrows and adjust zoom and focus, then click SET button under Preset. Now change preset number to 2 by clicking number 1 and selecting 2 from the drop down table, and using the arrow buttons move camera to the second preset point then click SET button. Continue until all presets have been added.

To initiate a tour using the MEGA DVR you can select the PTZ option by clicking on the Menu, then Video, then PTZ. Set Patrol number using down arrow key and then click on the Set button to display a Keypoint Box. Select each Preset Number (Preset 000 ~ 220), Duration (1 ~ 30 seconds at this keypoint) and Speed (1 ~ 40) with lowest number being slowest speed). Repeat this for each preset set. Now click on PTZ, then click on Call Patrol button. The tour will now run. To stop tour click on PTZ Control arrow icons.

Special Note

There are many types of keyboards available to control these PTZ cameras. Some keyboards have a CALL command and others have a SHOT command but they are identical. Commands are usually constructed of three parts. A keyboard that has an Enter key requires **<command> <value> <enter>** for example, however other keyboards the enter is combined with the command so only uses **<value> <command>**.

Getting the PTZ up and running!



You **MUST** connect up the PTZ and your control equipment on a workbench or kitchen table before the actual site installation and **CHECK YOU KNOW HOW TO INSTALL IT CORRECTLY!!!!!!!!!!!!!!!!!!!!!!**.

By doing this you can set-up any DIP switches, adjust the camera, and learn about how it operates before taking it to site. This will save you hours of time on-site trying to work out why a particular item doesn't function as you expected it to. There is nothing worse than installing something and then having to take it down to see how to get it working!! Do the learning curve in the comfort of your own premises!!!!

Do you KNOW how to install PTZ equipment that is controlled by RS485 data signals or via Coaxitron?

If not please read the following introduction to PTZ >>>....

Overview- introduction to fitting PTZ equipment

Generally speaking, 12vDC Mini 4in1 PTZs require three things;

- 1- They require a power supply and a cable to supply this power to the PTZ. They operate on 12V D.C.
- 2- They require a cable to get the video signal back to the monitor or recording device.
- 3- They require a cable to transmit the "RS485 control signal" from the keypad or DVR to tell the PTZ to pan and tilt etc. Alternatively you can control a TVI PTZ using an Alien HD-TVI DVR, by using the coaxitron option through the video cable. This method obviates the need to use RS485, so a number of these PTZ cameras can be installed leaving them all on the same default RS485 settings and accessing only from the Alien HD-TVI DVR with the AlienTVI(Coaxitron) protocol set in the DVR PTZ menu settings.

The following diagram indicates the basic cable requirements for a PTZ system.

Wiring Considerations

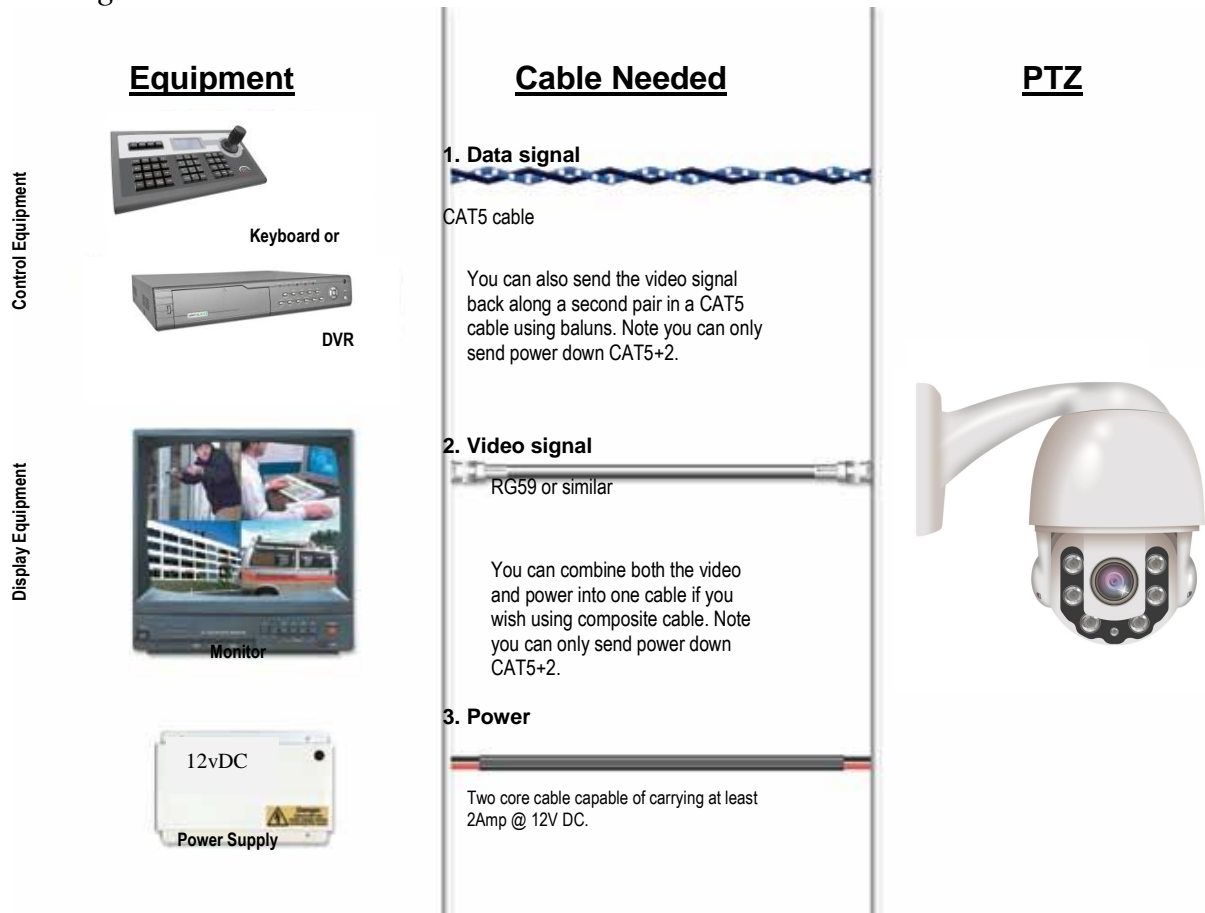

You can get “composite” cables that will carry both the power and the video signals and this has the benefit of combining two of the three cables into one. You may choose to power the PTZ locally to it, so you may only need to get the video signal back from the PTZ and the RS485 control signals to it. If this is the case you may choose to use a pair of HD TVI BALUNS. By using baluns you can send the video signal and control signal down the same CAT5 cable just using different cores for each signal.

The data signal (RS485) is nearly always sent along a “twisted-pair” type cable. The twists in the cable help prevent interference affecting the data signal by “shielding” it. Many installation companies use a CAT5 type or similar cable to run out to the PTZs to carry the data signal. Baluns are not needed for data. Of course when using coaxitron an RS485 connection may not be needed.

If you are considering using TVI Baluns please note - DVR’s tend to require good video signals to function correctly and will work up to 200 metres. Note there are no active HD baluns available currently. If there is a longer distance needed then standard co-ax cable, shotgun or Combo cable will give up to 500 metres for video, but this does not apply to power. Never put power on CAT5, use the CAT5 + 2. The power cable on CAT5+2 or shotgun should work up to 25 metres and on the PTZ Combo cable, up to 30 metres. See the section on “Powering the PTZs” later on in this manual.

Coaxitron and RS485

These Mini 4 in 1 PTZ cameras have telemetry control through either the RS485 cable or up the co-ax using the coaxitron facility. The benefit of using coaxitron is that there is no need for an RS485 connection. However PTZ control must be via the DVR and the AlienTVI(Coaxitron) option selected for the relevant camera set in the PTZ menu settings.

If there is a requirement to use a keyboard, the keyboard must be connected via RS485 so the PTZ menu settings must be set with the standard RS485 protocol, baud rate and ID as set in the camera rather than the coaxitron method.

When using the PTZ790 rather than a standard PTZ keyboard you can use the coaxitron facility via the DVR mode and RS485 via the PTZ mode. However you first need to setup the RS485 settings in the DVR PTZ menu ensuring that the protocol is PELCO-D, baud rate 9600 and ID <nn> (nn = 01 by default) and save and reboot DVR. Then change the protocol to AlienTVI(Coaxitron) and reboot DVR again.

Many installation companies can get the power and video signal correct, but struggle with the control of the PTZ using the keypad or DVR using the RS485 data. The key to successfully installing the data cabling to the PTZ is to get the basics right. Use a quality data cable such as CAT5 (never use just a standard untwisted cable such as alarm cable for the RS485 signal).

Also, you must follow the RS485 wiring convention; the following section explains this:

RS485 Wiring methods & Tips >>>>>

1. Characteristics of RS485

As specified by RS485 standards, RS485 is a half-duplex data transmission type with characteristic impedance of 120Ω. The maximum load capacity is 32 units (PTZs, keyboards and DVRs).

2. Transmission distances of RS485 Signals using CAT5 or similar cables

Selecting a CAT5 or similar sized twisted pair data transmission cable, the maximum theoretical transmitting distances are as follows:

Baud Rate	<u>Maximum</u> Transmitting Distance
2400 Bps (PELCO-D)	1500m
4800 bps	1000m
9600 bps	600m

PLEASE NOTE - Using inferior cables, or installing the PTZ in an environment with strong electromagnetic interference, or connecting a lot of PTZ domes to the same cable carrying the RS485 signal will reduce the maximum transmitting distance.

3. RS485 Connection methods

METHOD 1 – DAISY CHAIN CONNECTION.

The general RS485 standard recommends a “daisy chain” connection of equipment that is to be controlled. This means that the control cable is looped out of the one PTZ to the next PTZ and so on. The last PTZ in the line is then fitted with what is known as a “termination resistor”. This has a value of 120 Ω .

The keyboard itself generally has a built-in 120 Ω resistor. These termination resistors help make the signal more stable and give the system better reliability so the PTZs function as expected. A common mistake installers make is not making sure the 120 Ω resistor is fitted on the LAST PTZ. Also installers often set the termination in another PTZ in the chain; these errors will make control of the PTZ unpredictable.

A simplified Daisy chain is shown below:

This first diagram shows the cables looping in one PTZ and out of another;

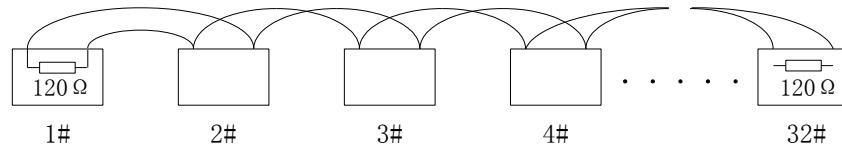

Standard Daisy-Chain connection for the RS485 PTZ control signal

(just the last PTZ should have the 120Ωresistor set to on, the first device is the keyboard and has the 120Ω built in as default)

This next diagram is a slight variation on the Daisy Chain arrangement. Again it’s one cable going out to all the PTZs but instead of the cable going into each PTZ then back out to the next one, a junction box is used to “Spur-Off” to each PTZ. Whilst this can be done THE SPUR LENGTH (D) must be NO MORE THAN 10 metres!!!!!!!!!!!!!! The overall cable length between the Controller and the last PTZ is limited to around 300 metres in such an arrangement.

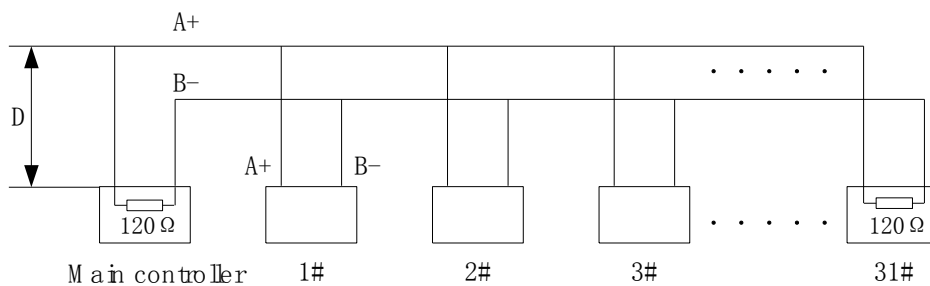

Daisy-Chain connection WITH SHORT SPURS for the RS485 PTZ control signal

(one main radial with very short spurs to each PTZ off it, keeping the spurs to less than 10 meters)

STAR method of connection.

In some circumstances you may need to adopt a star configuration for practical purposes. For instance, all the PTZs may be so scattered on a large site that running out separate spurs to each PTZ in a “STAR” array is the only practical solution.

So how do you do this in practice?

The termination resistors must be connected to the two PTZs that are farthest away from each other, such as PTZs 3 and 5 in the following “Star diagram”. Note that all the other PTZs do not have the 120Ω resistor connected. The resistor on this PTZ is enabled using dipswitch 4 on the short bank of dipswitches. ON sets termination and OFF switches it off.

As the star configuration is not in conformity with the requirements of RS485 standards, problems such as signal reflections may arise, especially when there are long cable connections. The results are that control signals are decreased and the PTZ may not respond to, or just responds intermittently to the controller.

If your STAR circuit is not too extensive with each spur in the region of 20-50 metres you can expect quite good reliable performance using this technique.

The Star circuit for wiring PTZ's.

The two furthest PTZs need the 120Ω resistors enabling. *In this example it's PTZs 3 & 5.*

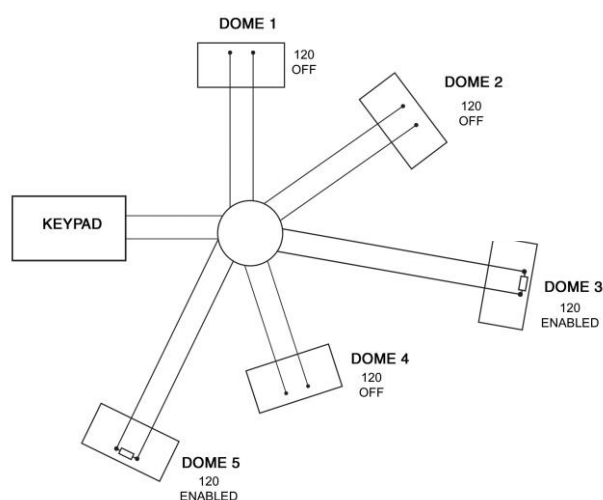

In the real world not everything always works exactly as it's expected to!

RS485 data signals that control the PTZs' movements are tiny signals that can get corrupted for many reasons. Poor cable quality, not using a PAIR of cores from a CAT5 but using one core from TWO separate pairs, running the CAT5 cable near mains equipment such as florescent lighting all will have a detrimental effect on the signal. These are things that you can correct with good installation practices. Where you wish to run several separate CAT5 cables out to send the RS485 data signal out to the PTZs you are in effect correcting the STAR method of RS485 data distribution. As previously mentioned the problem with the Star method is that it is not actually designed for RS485 but generally works okay if you follow the previous notes on getting the 120Ω resistor setting right. One way that takes the guesswork out of installing the Star method is to utilise an RS485 distributor.

Setting up the PTZ Camera

1. Connection of the System

There are many ways to wire up a PTZ system.

If you have read the introduction at the beginning of these instructions you should have got a good idea what your options are.

Below is a general schematic diagram showing you some of these options.

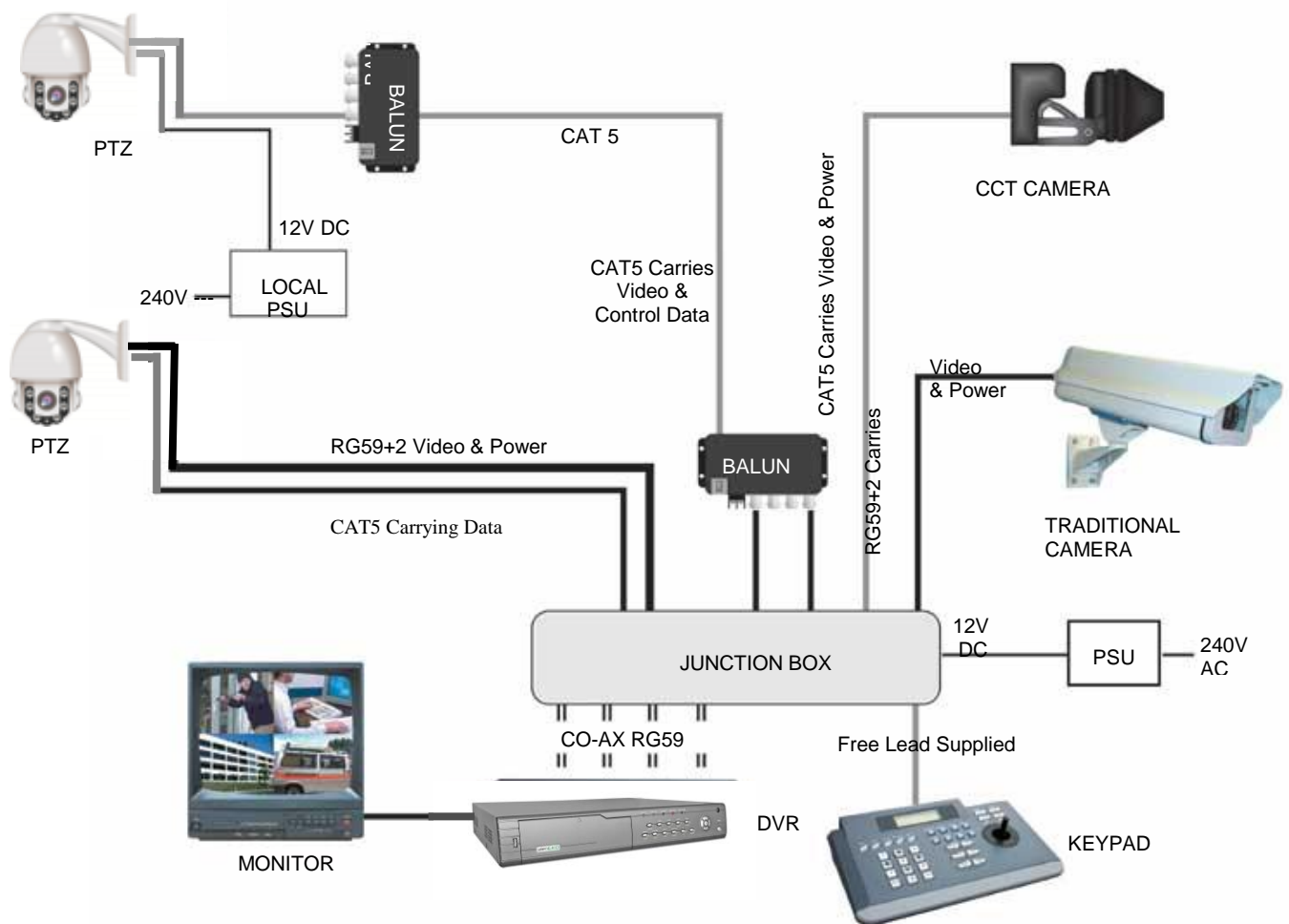

Powering the PTZs

All the PTZs will need power. For this PTZ it is a 12V D.C power supply. The power supply must be capable of delivering at least 2A per PTZ.

A popular way to power the PTZs is using our COMPOSITE VIDEO cable (or shotgun as its also known) as this cable can carry the power to the PTZ and the video signal back to the monitor or DVR.



Do not use RG59+2 for power if run is longer than 25 metres. Either power locally at shorter distance or use heavier duty cable.

The following tests were undertaken with these cameras using RG59+2, IRs full on and the PTZ camera running a pan.

- ✓ RG59+2 run at 15 metres - voltage 11.27v DC - current 920mA
- ✓ RG59+2 run at 25 metres - voltage 10.0v DC - current 1.0A Maximum run distance
- ✗ RG59+2 run at 35 metres - voltage 9.52v DC - current 1.035A Video/telemetry issues

You can either power each PTZ with its own PSU locally to it or have the PSU's remotely situated perhaps near the keyboard or DVR. Ensure that the power cable if using shotgun cable is no longer than 25 metres between camera and power supply. If the voltage of the PTZ drops below 10V D.C it may fail to initialise or produce intermittent video and or telemetry issues. Obviously you can power the PTZs locally if you wish.

If distance is greater than those mentioned previously, a heavier power cable must be used to avoid voltage drop. Using Combo cable then maximum run distance will be 30 metres.

As voltage drops the amperage through the power supply increases which may result in damage to the power supply. As problems may occur at night when the IRs switch on, covering the IR sensor to switch on IRs during a daytime installation is recommended to test the PTZ camera before leaving site.

The power connection

The RED & BLACK cable coming out of the PTZ are for power. Connect a suitable 12V A.C power supply to this pair of cores.

The BNC connector is the "VIDEO-OUT" from the camera and goes to an HD-TVI monitor or "VIDEO-IN" of a HD-TVI DVR camera input.

The White and Green cores are the data cables. These are the cores that carry the RS485 control signal to the PTZ from either the keyboard or the DVR. The White cable is the RS485+ and the Green is the RS485 - cable. The next section of the instructions gives more detail on how to connect the RS485 data. Please also read the RS485 WIRING METHODS & TIPS section towards the beginning of these instructions.

If the voltage of the PTZ drops below 10V D.C it may fail to initialise or produce intermittent video and or telemetry issues. Obviously you can power the PTZs locally if you wish.

RS485 connection - Connecting the Keypad or DVR to the Dome.



The dome is controlled by an RS485 data signal that is given by either a KEYPAD or a suitable DVR. This data signal tells the dome to pan, tilt, zoom etc. It is important that you read the early section of these instructions to understand the fundamental principle of RS485 cabling techniques so that you get it right.

RS485 has two cores, A and B or sometimes known as RS485 + (A) and RS485 – (B) if you get these two the wrong way around then you will not be able to control the dome. Sometimes installers get the connections right on one dome but not on the other and find only one dome works. They then swap the wires around at the keyboard only to find out one dome has now burst in to life and the other one now failed!! But they don't put 2 + 2 together and realise their mistake that they have wired one dome different to the other. Take great care getting these the right way around and make sure you wire each dome IDENTICALLY so that if you have to swap the A & B lines over at the keyboard you know all domes are wired the same!!

The Mini 4 in 1 PTZ camera range adopts the following RS485 convention:

WHITE = RS485 + or A

GREEN = RS485 – or B

You should initially be wiring the dome to the keyboard or DVR on your workshop bench or at least your kitchen table to prove you know how to get everything to work. Once you have done this, it is just a job of extending the cables and physically installing the domes on site. You must obviously take note of the RS485 wiring techniques mentioned at the beginning of these instructions and get the 120ohm resistors correct in the "End of line" domes. Generally speaking you will always be extending the RS485 signal from either the keypad or the dome using a CAT5 or similar cable.

The PTZ735 is one of the keypads that can be used. On the rear of the keypad you will see the RS485 connections. Ensure they are connected correctly i.e the RS485 + Ta line and the RS485 – Tb line as per 1 below.



PTZ735

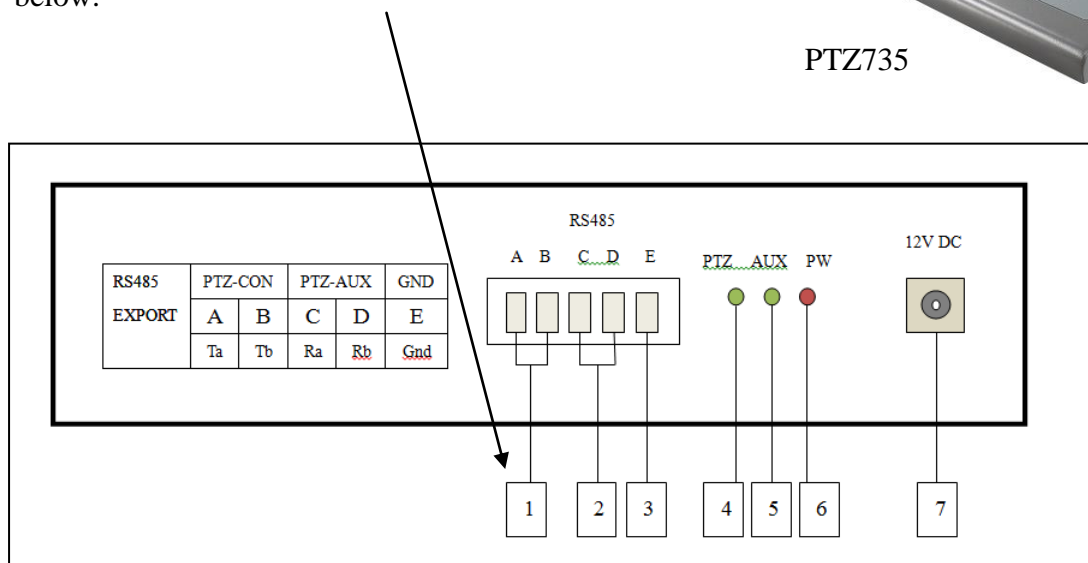

PTZ-CON Transmit RS485 to PTZ camera

Ta = RS485 + Tb = RS485 –

If you use cores from two different pairs in the CAT5 cable you will not get the benefit of the shielding effect of the cable twists and the dome will function erratically. You must always use a core from a PAIR, not two cores from two different pairs!!

Connecting the video out of the PTZ

The Mini 4 in 1 PTZ has a short BNC lead attached to it, this is the lead that carries the video signal from the built-in camera. You need to extend this lead to the “VIDEO-IN” of the DVR or monitor. Use a good quality RG59 coax cable or similar to do this.

Note that this is an HD-TVI PTZ camera and if using RG59 this should allow a run of up to 500 metres. If you are using CAT5 then you will need special HD-TVI passive baluns at both camera end and DVR end but the maximum run must not be more than 200 metres.

TIP – If you can’t get a picture at the remote end you could always take your TVI test monitor to your PTZ and check the picture quality on its own short BNC lead.

If you’re testing the equipment on a workbench you now have a one PTZ system.

For setting up the keyboard and testing the PTZ please read sections on default PTZ settings and using the keyboard.

If you’re controlling more than one PTZ on a site using RS485

Each PTZ has a unique “address” so that if you are using more than one on a site the keyboard “talks” to the right unit when you want it to PTZ. If you only have the one PTZ on the site then the default “address” of “1” is okay and you have no reason to change the PTZ from this. With multiple PTZ sites you need to set up each PTZ address separately. If you are using the Coaxitron facility on the Alien DVR there is no need to set any RS485 settings.

Setting up a unique ADDRESS and Baud Rate in the PTZ

There is a bank of 12 dipswitches on the face of the PTZ dome below the lens. The first 8 switches are used for the address and dipswitches 9 and 10 are used for the baud rate. Dipswitch 11 is unused and 12 is the termination switch. Note that the protocol is detected automatically.

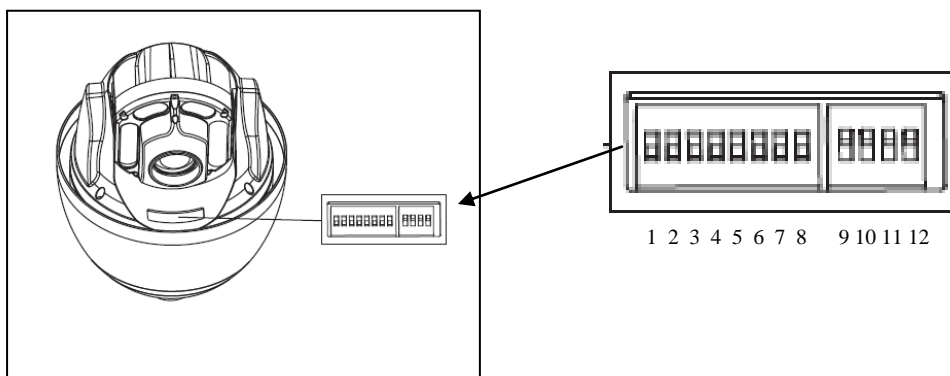

Setting Address

To set the PTZ address at 1 put switch 1 up.

To set the PTZ at address 2 put switch 2 up

To set the PTZ at address 3 put switches 1 & 2 up.

..and so on..

Note that these PTZs are shipped with dipswitch 1 set to on for address 1. If you are installing more than 1 PTZ camera then you must change the IDs in other PTZ cameras as they must be unique.

The following table indicates how this is done.

Dome Address	ID-CODE Status							
	DIP-1	DIP-2	DIP-3	DIP-4	DIP-5	DIP-6	DIP-7	DIP-8
1	ON	OFF	OFF	OFF	OFF	OFF	OFF	OFF
2	OFF	ON	OFF	OFF	OFF	OFF	OFF	OFF
3	ON	ON	OFF	OFF	OFF	OFF	OFF	OFF
4	OFF	OFF	ON	OFF	OFF	OFF	OFF	OFF
5	ON	OFF	ON	OFF	OFF	OFF	OFF	OFF
6	OFF	ON	ON	OFF	OFF	OFF	OFF	OFF
7	ON	ON	ON	OFF	OFF	OFF	OFF	OFF
8	OFF	OFF	OFF	ON	OFF	OFF	OFF	OFF
9	ON	OFF	OFF	ON	OFF	OFF	OFF	OFF
10	OFF	ON	OFF	ON	OFF	OFF	OFF	OFF
255	ON	ON	ON	ON	ON	ON	ON	ON

One keyboard can therefore control up to 255 x PTZ cameras

Setting the Baud Rate

Dipswitches 9 and 10 are used for setting the baud rate. You have four dipswitch settings. These are 2400bps, 4800bps, 9600bps or Identify Automatically.

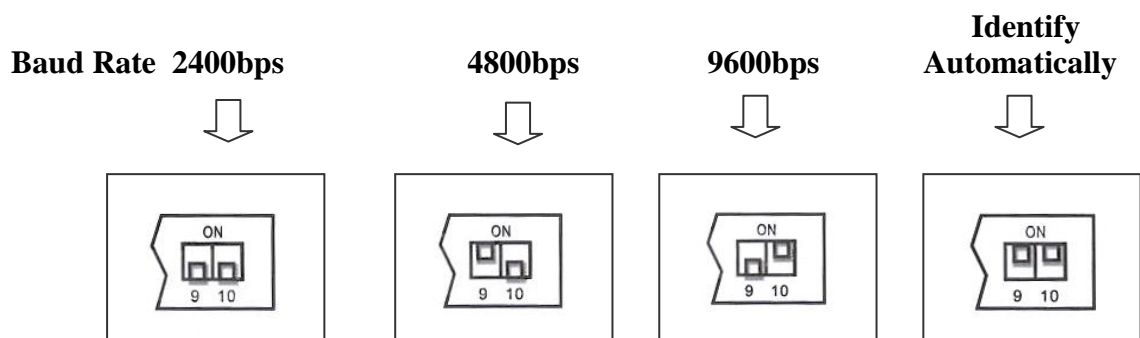

If the Identify Automatically switches are set, the PTZ will, like the protocol setting, automatically set both the protocol and baud rate dependent on what the PTZ detects. It is there important to ensure that the PTZ settings in control equipment are setup in advance of connecting the PTZ camera if automatic detection is required.

Using the PTZ735 keypad with the PTZM range of camera



PTZ735

NOTE 1: For more detailed instructions in setting up the keypad or using one of our other keypads, please refer to the instruction manual supplied with the product.

NOTE 2: The PTZ735 keypad requires you to press the function key first followed by the value e.g **<CAM> 01 <Enter>** whereas some keypads require the value first, then the function e.g **01 <CAM>**

When you first take the keyboard out of the box you will need to set it up for the domes that you are using.

The dome you have purchased has the default settings of PELCO-D 2400-Baud Rate Address 1

RS485	PTZ-CON		PTZ-AUX		GND
EXPORT	A	B	C	D	E
	Ta	Tb	Ra	Rb	Gnd

Rear of PTZ735 keypad

Connect RS485 to Ta and Tb

The RS485 from the PTZ camera must be connected to the back of the PTZ keyboard using the connection A and B in the above diagram. Note that RS485+ = Ta and RS485- = Tb. These connections are polarity sensitive and will only work provided both keyboard and PTZ camera are same polarity.

First select the required camera number by pressing **Addr <nn> Enter** (where nn = camera no.) Aim the dome where you want it to look, zoom in or out to get the correct scene and let the camera auto focus. Now press the following keys on the keypad : **PRESET <pp> Enter** (where pp is the preset number you wish to store). For example **PRESET 1 Enter** would set preset 1 and the camera would always go to this location when preset 1 is called using Shot key.

NOTE: The keypad remembers that it is in preset mode. You can add a number of presets just by entering the Preset number and Enter providing the LCD displays shows

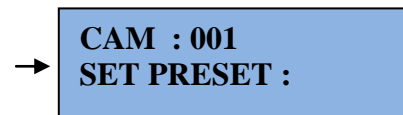

To test if the preset is stored correctly in the dome, use the joystick to move the camera to point in a new location. Now press **SHOT <ss> Enter** (where xx is the preset you wish the camera to go to). In this example if you press **SHOT 1 Enter** the dome should go straight to the PRESET 1 location. If you have multiple domes you will need to change the address of each dome so they are different but PLEASE LEAVE THE DOMES ON PELCO-D 2400 BAUD RATE.

- see NOTE 2 above.

PRESETS and other functions.

This PTZ camera has up to 220 presets that once programmed will stay in the PTZ's non-volatile memory so they will be retained even after a power cut.

What is a preset? A preset is a particular area or object that the PTZ was looking at and has been stored into its memory so when the preset is "called-up" the PTZ will select the area again without the operator using the joystick to do this. Even the zoom at the time is stored into the preset. This means that you could for example store a PRESET of a car-park entrance. When the operator calls up this preset the camera automatically zooms in on this area. By storing more than one preset you can add even more functionality to the PTZ. By having two presets, you can then get the PTZ to "SCAN" between the two locations. You can even vary the speed of this scan.

Having 3 or more presets you can get the PTZ to go on a TOUR (PATROL) of the presets. When you run the patrol the PTZ goes to one preset, then waits a short period then on to the next preset and so on. The PTZ continues to cycle around this patrol until you cancel it. The length of time the camera stays at one location and the speed of travel between each preset point can be set in the menu.

PRESETS -How to set up a preset

Aim the PTZ where you want it to look, zoom in or out to get the correct scene and let the camera auto focus. Now press the following keys on the keypad : **PRESET xx Enter** (where **xx** is the preset number you wish to store). For example **PRESET 01 Enter** would store **PRESET 01 and the camera would always go to this location when 01 is "CALLED"**.

Note that some keyboards use the **SHOT** command to CALL a preset.

To test if the preset is stored correctly use the joystick to move the camera to a point in a new location. Now press **CALL xx Enter** (where **xx** is the preset you wish the camera to go to). In this example if you press **CALL 01 Enter** the PTZ should go straight to the PRESET 01 location.

TIP -You may wish to write down a list of presets that you have stored next to the keypad for the operator.

CALLING a preset

This may be as follows:

PRESET 01 = MAIN GATE (a long zoom shot)

PRESET 02 = ENTRANCE DOOR

PRESET 03 = FIRE ESCAPE

PRESET 04 = EMERGENCY EXIT

PRESET 05 = CAR PARK (zoomed-out wide angle)

PRESET 06 = CAR PARK (zoomed-in narrow angle)

When the operator wishes to quickly zoom in on the MAIN GATE all he has to do is press **CALL 01 Enter**.

To go to the EMERGENCY EXIT he would press **CALL 04 Enter** and so on.

To call up any previously stored preset camera location, simply press **CALL xx Enter**, where **xx** is the preset number.

Patrols (Tours) – How to set them up and use them

A patrol (tour) is simply a collection of at least three preset camera locations that are run in sequence with the PTZ stopping at each location for a brief period of time and then moving on to the next preset.

For example, you could use a patrol so that an outside PTZ camera points at a gate, then at a side doorway, then zooms out to get an overall shot of a car park and finally zooming in on a

delivery bay, before repeating the whole cycle again. Patrols can be useful for both outside and internal PTZ's. For a shop they could be used to cover key areas like clothes rails, tills and changing rooms in a sequence.

To set up a patrol you need to set up the individual stop points where the camera will pause. These are called *presets*.

An example four preset mini-tour

Setting the presets using the keypad

STEP 1- Using the keypad joystick, move to where you wish to start the tour and then press **PRESET 01 Enter**

STEP 2- Now move to the next location and press **PRESET 02 Enter**

STEP 3- Now move to the third location and press **PRESET 03 Enter**

STEP 4- Finally move to where you wish to end the tour and press **PRESET 04 Enter**

Deleting a preset

You may wish to delete a preset.

You can set up to 220 presets but to run a patrol you have to enter the menu and select a patrol number and then allocate the presets that you require. So if you need to change an existing preset just use the **PRESET xx Enter** command (xx = preset number) after moving to the new position. This will overwrite the existing preset.

Alternatively you can enter the menu with **CALL or SHOT 95 Enter** then **SYSTEM SETTING** then **PRESET** and select appropriate preset number, you can then move down to **REMOVE** to remove it.

Note that if this preset is removed then it will be necessary to edit the Patrol menu to remove the preset.

Setting the Patrol (Tour)

To setup the patrol/tour you need to enter the Advanced Menu System by selecting **<CALL> 95 <Enter>** on the keypad. (Call varies according to module type). You will see the **Main Menu** displayed on the screen. Note that the **&** character needs to be moved into editing mode by moving the right arrow and left to exit.

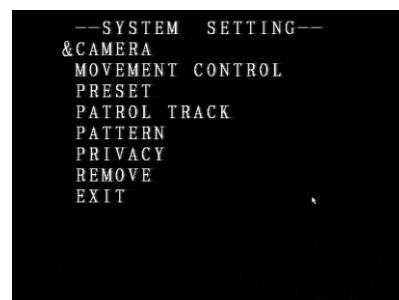
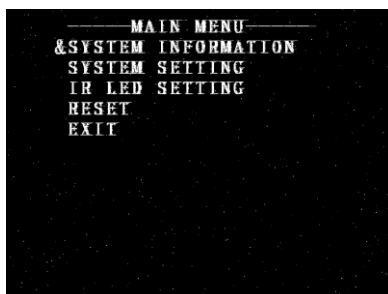

Move down to **System Setting** and then the right arrow key to enter. Click the up or down arrow key to enable edit mode and then press the down arrow key and move to **Patrol Track**. Then press the right arrow key to enter the Patrol Track menu.

```

--SYSTEM  SETTING--
CAMERA
MOVEMENT CONTROL
PRESET
&PATROL TRACK
PATTERN
PRIVACY
REMOVE
EXIT

```

```

---PATROL  TRACK---
&NUMBER      001
EDIT
RUN
REMOVE
EXIT

```

Now press the right arrow key to enter the Patrol Track menu.
 Now press the OPEN button or IRIS+ button again to change the & sign to : to select the Patrol/Tour number. For this example we are using 001 as patrol/tour number one, so we do not need to edit this if this is the first patrol or tour. Using the up or down keys, alter the Patrol/Tour number (001 ~ 008). Click the OPEN button or IRIS+ button again to save the change. The : will change back to a &.

```

---PATROL  TRACK---
↑NUMBER      001
EDIT
RUN
REMOVE
EXIT

```

```

---PATROL  TRACK---
NUMBER      001
&EDIT
RUN
REMOVE
EXIT

```

Now use the arrow button to move down to Edit and press the OPEN button or IRIS+ button to enter the Patrol Track menu.

Now press the OPEN button or IRIS+ button again to change the & sign to ↑ and press up arrow key to select preset number. Press the OPEN button or IRIS+ button again to save change. This will now allow you to move using the right arrow button to update the speed parameter.

NO.	PRE	SPD	TIME
01	&001	007	002
02	002	021	002
03	003	008	003
04	004	040	002
05	---	---	---
06	---	---	---
07	---	---	---
08	---	---	---

Use the same method to set the Time.

Note that the maximum number of presets that can be set are 220. The Speed range is from 0 ~ 063 which is the movement time speed between presets. The Time parameter is the number of seconds that the PTZ will stay at the preset position and that can be from 0 ~ 240 seconds. Complete the table for all presets and press the CLOSE or IRIS- button to exit out of each menu.

Calling the Patrol (Tour)

To initiate a tour enter <CALL/SHOT> <nn> <Enter> or <nn> <CALL/SHOT> on the keypad. (where **nn** = 35 ~ 38) e.g 35 = Patrol 1, 36 = Patrol 2 etc.

Alternatively enter <CALL/SHOT> <nnn> <Enter> or <nnn> <CALL/SHOT> on the keypad. (where **nnn** = 231 ~ 238) e.g 231 = Patrol 1, 232 = Patrol 2 etc.

Special Note: If you notice that some expected presets are not being incorporated in the patrol/tour, check that the PRESET table in the camera menu, has been setup correctly and shows all presets for the required sequence.

TIP - To stop the PATROL just move the joystick slightly.

AUTO SCAN (AB Scan)- How to set it up

Auto-scan scans between two points. These are not presets as per the patrol (tour) facility but auto scan selection points. You may program one auto scan.

Select the camera by pressing the <CAM/Addr> <camera number> <Enter> on the keypad or <camera number> followed by <CAM/Addr> button.

To setup the Auto Scan you need to move to the start position and enter

<CALL/SHOT> **92** <Enter> or **92** <CALL/SHOT> on the keypad.

Alternatively enter <CALL/SHOT> **221** <Enter> or **221** <CALL/SHOT> on the keypad.

You should see the message "**A point has been set**" displayed on the screen.

Now move to the end position of the Auto Scan and enter <CALL/SHOT> **93** <Enter> or **93** <CALL/SHOT> on the keypad.

Alternatively you can enter <CALL/SHOT> **222** <Enter> or **222** <CALL/SHOT> on the keypad.

You should see the message "**B point has been set**" displayed on the screen.

You can also setup the Auto Scan through the menu system and can trigger by an alarm.

Move down to **System Setting** and press the OPEN button or IRIS+ button on the keypad and move to the **Movement Control** menu use the up and down direction keys on the keyboard. Now press the OPEN button or IRIS+ button to enter the Movement Control menu.

Move down to **AB Scan Setting** using the up and down direction keys on the keyboard. Press the OPEN button or IRIS+ button to display "**Set A Point First**".

Move to the start position and then press OPEN button or IRIS+ button. You will see the message "**Then Set B Point**" displayed on the screen. Now move to the end position of scan and press OPEN button or IRIS+ button again.

Calling the Auto Scan (AB Scan)

First you must set the start and end positions of the auto scan as above. This runs the auto scan function between these two points. To call the AB Scan enter h

<CALL/SHOT> **98** <Enter> or **98** <CALL/SHOT> ... Auto Scan at **High Speed**
<CALL/SHOT> **97** <Enter> or **97** <CALL/SHOT> ... Auto Scan at **Middle Speed**
<CALL/SHOT> **96** <Enter> or **96** <CALL/SHOT> ... Auto Scan at **Low Speed**

<CALL/SHOT> **223** <Enter> or **223** <CALL/SHOT> ... Auto Scan at **High Speed**
<CALL/SHOT> **224** <Enter> or **224** <CALL/SHOT> ... Auto Scan at **Middle Speed**
<CALL/SHOT> **225** <Enter> or **225** <CALL/SHOT> ... Auto Scan at **Low Speed**

TIP - To stop the scan just move the joystick slightly.

If you need to run a 360° continuous scan <CALL/SHOT> **99** <Enter> or **99** <CALL/SHOT>

If you need to run the Auto Scan covering the route outside the AB points use <CALL/SHOT> **226** <Enter> or **226** <CALL/SHOT> but if you decide to move the scan between the AB points use <CALL/SHOT> **227** <Enter> or **227** <CALL/SHOT>

RECORD PATTERN- What is a record pattern

This dome has an option to store a record pattern. A record pattern consists of a continuous sequence of standard pan and tilt movements or lens commands. The maximum time of the recording is related to the number of actions recorded, but the recording should last for at least a 120 second interval. A record pattern does not use presets. You can limit movement at a required position and pan and tilt and a percentage value is displayed advising memory resource available. Once the recording is complete, i.e you have closed the recording or the record resource has been used, you can select a Preview option to replay the recorded pattern. You can also remove the pattern or re-edit. Up to four different patterns may be recorded.

RECORD PATTERN- What is the difference between a pattern & a patrol (tour)

A patrol (tour) uses presets and when initiated, the dome will move to a maximum of 32 preset positions using the dwell times as set in the Patrol Table. The speed of dome movement between any two presets can be set from 000 ~ 063. A patrol (tour) can run for an extensive length of time with a dwell time of a maximum of 240 seconds at each of the preset positions. In addition up to eight different patrols (tours) can be stored each with different preset parameters whereas only four record patterns can be recorded. When a preset is stored the dome stores not only the preset position but also zoom and camera attributes. A record pattern does not record zoom attributes.

A record pattern does not use presets. It however allows the user to record a continuous sequence of standard pan and tilt movements or lens commands. The record pattern sequence can be recorded using the keypad pan and tilt joystick and records for a number of changing activations that should give a recording duration of more than 120 seconds. A record pattern allows the user a continuous view rather than selected preset positions and is similar to an auto scan except that an auto scan only allows a selected movement between two points whereas the record pattern reflects all the user movements made during the recording of the record pattern.

RECORD PATTERN- How to set it up

Record Pattern allows a pattern to be recorded which consists of any standard pan and tilt or lens command within a 120 second interval. A pattern is automatically closed when the interval is exceeded or by pressing the CLOSE button.

STEP 1 – Select the required camera by pressing the **CAM/Addr** button and entering <camera number> followed by <**Enter**> on the keypad or <camera number> followed by <**CAM/Addr**>

Position the camera where you wish to start the record pattern sequence. Enter Main Menu by selecting <**CALL/SHOT**> **95** <**Enter**> or **95** <**CALL/SHOT**> on the keypad.

You will see the **Main Menu** displayed on the screen.

Using the joystick up/down direction movement, select the **SYSTEM SETTING** menu.

Press the **OPEN** button or **IRIS+** button to enter menu and move down to Pattern using joystick.

Press the **OPEN** button or **IRIS+** button to enter Pattern menu.

STEP 2 - In the **PATTERN** menu select **PATTERN NUMBER** from 1 ~ 4 by pressing the **OPEN** button or **IRIS+** button to change the **&** to **:** in order to update the pattern number. Use the joystick up and down movement to select the required pattern number. The press the **OPEN** button or **IRIS+** button to change the **:** back to **&** again.

STEP 3 – Now move the joystick down to **Edit** to record this pattern number. Press the **OPEN** button or **IRIS+** button to commence recording. Move the joystick to record the pattern. The display **Record Pattern x** (where x is pattern number selected) followed by **Free Space %** changes to a reducing value from **99%** as recording takes place. You should get at least a 120 second sequence but total time depends on the number of movements undertaken. Press the **OPEN** button or **IRIS+** button to close the recording or until the record period expires. The record pattern will be stored for future replay. If you select **RUN** you can replay the pattern or go to **Remove** to remove it. Note that you need to press the **OPEN** button or **IRIS+** button to access and exit these menus. Press the **Iris -** to exit out of menu.

Running the Record Pattern

First you must have recorded a record pattern as detailed above. This runs a record pattern of at least a 120 second duration but is dependent on the number of movements made.

Press <CALL/SHOT> **71** <Enter> or **71** <CALL/SHOT> to run Pattern No.1

Press <CALL/SHOT> **72** <Enter> or **72** <CALL/SHOT> to run Pattern No.2

Press <CALL/SHOT> **73** <Enter> or **73** <CALL/SHOT> to run Pattern No.3

Press <CALL/SHOT> **74** <Enter> or **74** <CALL/SHOT> to run Pattern No.4

Alternatively you can enter

Press <CALL/SHOT> **241** <Enter> or **241** <CALL/SHOT> to run Pattern No.1

Press <CALL/SHOT> **242** <Enter> or **242** <CALL/SHOT> to run Pattern No.2

Press <CALL/SHOT> **243** <Enter> or **243** <CALL/SHOT> to run Pattern No.3

Press <CALL/SHOT> **244** <Enter> or **244** <CALL/SHOT> to run Pattern No.4

The CALL or SHOT commands are synonymous.

Preset Function Table

PRESET No.	Function	PRESET No.	Function
35	Call Patrol 1	221	Set AB Scan point A
36	Call Patrol 2	222	Set AB Scan point B
37	Call Patrol 3	223	Call AB Scan at High Speed
38	Call Patrol 4	224	Call AB Scan at Medium Speed
69	IR Filter On	225	Call AB Scan at Low Speed
70	IR Filter Off	226	Outside the Arc Scan
71	Call Pattern 1	227	Inside the Arc Scan
72	Call Pattern 2	230	Clear Screen
73	Call Pattern 3	231	Call Patrol 1
74	Call Pattern 4	232	Call Patrol 2
91+80	Call Camera Module Menu	233	Call Patrol 3
92	Set AB Scan point A	234	Call Patrol 4
93	Set AB Scan point B	235	Call Patrol 5
95	Call PTZ Main Menu	236	Call Patrol 6
96	Call AB Scan at Low Speed	237	Call Patrol 7
97	Call AB Scan at Medium Speed	238	Call Patrol 8
98	Call AB Scan at High Speed	241	Call Pattern 1
99	Call 360° scan	242	Call Pattern 2
		243	Call Pattern 3
246+1	Switch to TVI	244	Call Pattern 4
246+2	Switch to CVI	254	Motor Calibration
246+3	Switch to AHD		
246+4	Switch to CVBS (Analogue)	PTZ Reset	Call 246+ Call 10+ Call 12+ Call 14

USING THE DOME'S ADVANCED FUNCTIONS-

On Screen Graphics (OSD) PTZ Main Menu– Using a keypad

The PTZM400 range boasts four/eight patrol (tour) options depending on code used, one auto scan option and four record pattern options. All these can be configured using the OSD. To bring up the camera menu press <CALL/SHOT> **95** <Enter> or **95** <CALL/SHOT> (varies with module type).

Alternatively this TVI PTZ camera menu can be accessed directly from the MEGA or MAXPIX DVR using the coaxitron facility in the PTZ menu. This uses the up the coax connection. To access the control menu just right click the mouse, select the camera channel number in Single Screen, right click the mouse, select PTZ Control and then click the House to the right of the Configuration button using the left mouse button. If this fails click arrow to right of One-Touch twice, then enter 95 in Call Preset red box, click Enter then click Call Preset box. The menu is then displayed on the screen. You can navigate between the various options using the Joystick control – up to increase and down to decrease, IRIS+ to enter and IRIS- to exit. You need to use the OPEN or IRIS+ button to be able to edit changes and again to close edit.

THE PTZ MAIN MENU SYSTEM

Using the PTZ Main Menu System.

This menu system allows the user to alter the dome menu instruction options and settings using a control keypad. This first page shows the initial main menu page and only describes the general functions. The following pages show the main menu option selected on the left hand side of the page and a breakdown of that menu page on the right hand side of the page.

MAIN MENU

To enter the main menu system press

<CALL/SHOT> **95** <Enter> or **95** <CALL/SHOT>
on the Keypad or DVR or use the Coaxitron option.

Use the Joystick control pan up or pan down to select a menu,

the Open or IRIS+ to select and edit a value (the **&** changes to *****)
the joystick **UP** or **DOWN** to change a value, the Open or IRIS+ to
Open the edit and the CLOSE or IRIS- to exit the menu.

MAIN MENU & SYSTEM INFORMATION SYSTEM SETTING IR LED SETTING RESET EXIT
--

DESCRIPTION OF MENU OPTIONS

System Information: System Information / Communication Protocol / Baud Rate / Hard ID
Address / Soft ID Address / Soft address enabling / Software Version.

System Setting: Camera / Movement Control / Preset / Patrol Track / Pattern / Alarm / Privacy /
Remove

IR LED Setting: Control Mode / LED ON Level / LED OFF Level / Brightness / Current Level

Restart Camera: Restart Camera - Sure?

Reset: Reset Menus - Sure?

Exit: To exit menu.

```

MAIN MENU
&SYSTEM INFORMATION
SYSTEM SETTING
IR LED SETTING
RESET
EXIT

```

```

INFORMATION
&PROTOCOL          PELCOD
BAUD RATE          2400
HARD ADDR          001
SOFT ADDR          001
SOFT ADDR ENABLE   OFF
VERSION            xxxxxxxxxx
EXIT

```

Refer to pages 15/16

If you are using coaxitron connection then RS485 settings below do not apply. RS485 is only required if you are using keyboard control rather than Alien DVR control. Note that if you are using the PTZ790 keyboard that has Alien DVR and PTZ control, then access can be made using the coaxitron facility via DVR mode.

Protocol PELCOD

The communication protocol is self detected and does not need setting up.

Baud Rate 2400 / 4800 / 9600 / Automatic Identify

The Baud Rate is self detected and does not need setting up.

Otherwise the values are:

2400 baud rate Dipswitch 9 OFF - Dipswitch 10 OFF

4800 baud rate Dipswitch 9 ON - Dipswitch 10 OFF

9600 baud rate Dipswitch 9 OFF - Dipswitch 10 ON

Auto Detect Dipswitch 9 ON - Dipswitch 10 ON

The default is set at 9 & 10 OFF which is 2400 bps.

Hard Address

This is the ID address of the PTZ camera set in the first 8 dipswitches located under the plastic cover under the PTZ lens. The default is 1 i.e dipswitch 1 set to ON. Numbers are in binary format so ID number value =

Dipswitch Number: 1 2 3 4 5 6 7 8

Value: 1 2 4 8 16 32 64 128

So for example to set ID number 3, switch 1 & 2 ON, ID number 7, switch 1, 2 & 3 ON.

Soft Address

If you need to change the ID set in the camera it can be done manually as detailed in the above setting under Hard Address. Alternatively you can set the address using the Soft Address option. The address range is from 1 ~ 255. In order to supersede the Hard ID address you will need to switch Soft Addr Enable to ON. If you have over-riden the hardware address with a software address but cannot access the PTZ camera, then setting the hard address to 0 will allow you access the PTZ to find out the menu setting.

Soft Addr Enable

If you set this from OFF to ON the Hard ID set by the dipswitches in the PTZ camera can be over-riden by the software ID.

Version

Software version

SYSTEM SETTING

**SYSTEM SETTING
&CAMERA**
MOVEMENT CONTROL
PRESET
PATROL TRACK
PATTERN
ALARM
PRIVACY
REMOVE
EXIT

CAMERA
& SCREEN TIPS OFF
AUTO ICR OFF
AUTO FOCUS ON
FOCUS SPEED FAST
DIGITAL ZOOM OFF
ZOOM SPEED FAST
EXIT

Screen Tips ON / OFF

Switch ON to open the display tips for the Zoom function

Auto ICR ON / OFF

Switch to **ON** to enable IR operation.

NOTE: If this is set to OFF IR light will be blocked. This option may be set to OFF following a Reset.

Auto Focus ON / OFF

If switched to **ON** the PTZ camera will automatically adjust focus.

Focus Speed FAST / SLOW

This option is set to **FAST** by default or **SLOW** and affects the speed of auto focus.

Digital Zoom ON / OFF

Switch to **ON** to set digital zoom function.

Exit

Exit menu.

SYSTEM SETTING

MOVEMENT CONTROL

SYSTEM SETTING
CAMERA
&MOVEMENT CONTROL
PRESET
PATROL TRACK
PATTERN
ALARM
PRIVACY
REMOVE
EXIT

MOVEMENT CONTROL
&AUTO FLIP ON
PROPORTION PAN ON
PARK TIME NO
PARK ACT NO
POWER ACT NO
CONTROL SPEED HIGH
AB SCAN SETTING
AB SCAN PATH I-ARC
AB SCAN SPEED

Auto Flip ON / OFF

This option if switched to ON will allow the PTZ to auto flip 180 degrees when the PTZ is at its lowest point.

Proportional Pan ON / OFF

If this is ON then, when using digital zoom, the digital zoom speed increases or decreases according to the zoom distance.

Park Time 5 secs - 255 secs / OFF

This enables the PTZ to stay at the Park Action selected for a stipulated time.

Park Act AB SCAN / NO / PRESET 1 ~ 8 / PATROL 1 ~ 8 / PATTERN 1 ~ 4 / AUTO SCAN

Select the Park Action required from list.

Power Act AB SCAN / NO / PRESET 1 ~ 8 / PATROL 1 ~ 8 / PATTERN 1 ~ 4 / AUTO SCAN

This option automatically starts an action listed above when the PTZ is powered up.

Control Speed MEDIUM / LOW / HIGH

Sets the speed of the PTZ camera camera.

AB Scan Setting

This allows the setting of the two points in an auto scan.

AB Scan Path I-ARC / O-ARC

This option allows you to set the path for the auto scan to either the inner scan between the AB inner path or the outer scan between AB outer path.

AB Scan Speed HIGH / MEDIUM / LOW

This sets the speed of the AB auto scan.

SYSTEM SETTING

PRESET

SYSTEM SETTING
CAMERA
MOVEMENT CONTROL
&PRESET
PATROL TRACK
PATTERN
ALARM
PRIVACY
REMOVE
EXIT

PRESET
&NUMBER 001
EDIT
REMOVE
EXIT

Number **0 ~ 220**
Select preset number

Label **Preset number**
The preset label changes according to the preset number selected.

Edit
Allows adjustment for direction and lens zoom

Remove
Delete a preset number

Exit

SYSTEM SETTING

SYSTEM SETTING
CAMERA
MOVEMENT CONTROL
PRESET
&PATROL TRACK
PATTERN
ALARM
PRIVACY
REMOVE
EXIT

PATROL TRACK

PATROL TRACK
& NUMBER 001
EDIT
RUN
REMOVE
EXIT

Number 1 ~ 8

Enter the patrol track/tour number. You can set up to 8 separate tours each tour can accommodate up to 32 presets.

Edit 1 ~ 32 preset points

The Speed range is from 0 ~ 063 which is the movement time speed between presets. The Time parameter is the number of seconds that the PTZ will stay at the preset position and that can be from 0 ~ 240 seconds.

Run

Run the tour number selected. Invalid Patrol Track if no presets set for this patrol track/tour.

Remove

Removes the tour specified in Number above.

Exit

SYSTEM SETTING

SYSTEM SETTING
CAMERA
MOVEMENT CONTROL
PRESET
PATROL TRACK
&PATTERN
ALARM
PRIVACY
REMOVE
EXIT

PATTERN

PATTERN
& NUMBER
EDIT
RUN
REMOVE
EXIT

Number 1 ~ 4

Enter the pattern number. You can set up to 4 separate patterns.

Edit

You should get at least a 120 second sequence but total time depends on the number of movements undertaken.

Run

Run the pattern selected.

Remove

Removes the pattern specified in Number above.

Exit

SYSTEM SETTINGS

SYSTEM SETTING
CAMERA
MOVEMENT CONTROL
PRESET
PATROL TRACK
PATTERN
&ALARM
PRIVACY
REMOVE
EXIT

ALARM

ALARM	
&CHANNEL	001
ENABLE	OFF
INPUT	NO
OUTPUT	NO
STAY TIME	060
ACTION	NO
EXIT	

Channel **1 or 2**
Select the alarm channel 1 or 2

Enable **OFF / ON**
Switch the alarm on or off.

Input **NO / NC**
Set alarm for normally open or normally closed connection.

Output **NO / NC**
This PTZ has one output alarm either NO (normally open) or NC (normally closed).

Stay time **60 Default / FOLLOW / ALWAYS / 1 ~ 240 seconds**
Sets the alarm trigger time. Up and Down arrows 1~ 240, or Left or Right in 10s.

Action **NO / Preset 1 ~ 8 / Patrol 1 ~ 8 / Pattern 1 ~ 4 / Auto Scan / AB Scan**
Set the alarm option from preset, patrol, pattern, auto scan (continuous 360 degree scan) and AB scan for standard two point auto scan.

Exit

Remove
The remove in the System Setting Menu allows you to remove Presets, Patrols and Patterns.

SYSTEM SETTINGS

PRIVACY

SYSTEM SETTING
CAMERA
MOVEMENT CONTROL
PRESET
PATROL TRACK
PATTERN
ALARM
&PRIVACY
REMOVE
EXIT

PRIVACY
&NUMBER 001
EDIT
REMOVE
EXIT

SPECIAL NOTE: THE PTZM400 DOES NOT SUPPORT THIS FUNCTION

Exit
Click Iris- to return to previous menu.

SYSTEM SETTING

REMOVE

SYSTEM SETTING
CAMERA
MOVEMENT CONTROL
PRESET
PATROL TRACK
PATTERN
ALARM
PRIVACY
&REMOVE
EXIT

REMOVE
&PRESET
PATROL TRACK
PATTERN
EXIT

Preset

Press Iris+ button for preset removal. Press Iris+ button twice to remove presets.

Patrol Track

Press Iris+ button for tour removal. Press Iris+ button twice to remove tours.

Pattern

Press Iris+ button for pattern removal. Press Iris+ button twice to remove patterns.

Exit

Press Iris- to return to previous menu.

MAIN MENU

MAIN MENU
SYSTEM INFORMATION
SYSTEM SETTING
&IR LED SETTING
RESET
EXIT

IR LED SETTING

IR LED SETTING
&CONTROL MODE AUTO
LED ON LEVEL 220
LED OFF LEVEL 170
BRIGHTNE LOW POWER
CURRENT LEVEL 255
EXIT

Control Mode Auto / ON / OFF

Setting the Control Mode to Auto allows the CDS sensor to switch the IR lights on or off. If switched to ON the IRs will stay on permanently. If switched to OFF they will stay off permanently. Recommend changing to Auto.

LED ON Level 0 ~ 250

This is the level of light needed to switch on the IRs. Setting the value to 0 will switch the IRs on continuously. If the value is increased then the higher the setting the darker it has to be in order to switch on the IRs. The default setting is 220.

LED OFF Level 0 ~ 250

This is the level of light needed to switch off the IRs. Setting the value to 0 will switch off the IRs. If the value is increased then the higher the setting the lighter it has to be in order to switch off the IRs. The default setting is 170.

Current Level <value>

This display reflects the current IR level and cannot be edited.

Exit

Exit menu

Main Menu

MAIN MENU
SYSTEM INFORMATION
SYSTEM SETTING
IR LED SETTING
&RESET
EXIT

Reset

Resets camera menu and reboots camera following Sure? message.

Enter Open or Iris+ to continue.

Else enter Close or Iris- to cancel.

Exit Exit menu

THE CAMERA MODULE MENU

There is a further menu system in the PTZ camera module. This can be accessed using a

<CALL/SHOT> 91 <ENTER> <CALL/SHOT> 80 <ENTER> or
91 < CALL/SHOT > 80 <CALL/SHOT>

depending on the keyboard used or DVR.

IMPORTANT NOTE

The camera module provides a separate menu that may help resolve specific issues. Options generally set in the PTZ Main Menu System detailed previously, interface with the camera module. Therefore some options if changed, could result in a loss of communication between the main menu and the camera module. These are therefore locked and are not changeable.

Function	Default Value	Parameters	Changeable
LANG	EN	Language / Chinese only	✓
OSD-DISP	OFF	OFF / ON	✓
D & N	COL	AUTO/EXT/BW/COL	✓
MIRROR	OFF	OFF/FLIP/UD/LR	✓
BRIGHT	22	0 ~ 31	✓
WDR	OFF	OFF/ON	✓
SHARPNESS	14	0 ~ 31	✓
OUTPUT	TVI	-	x
FORMAT	1080 / 25	1080/25 720/30 720/25	✓
SAT	07	0 ~ 31	✓
CONTRAST	16	0 ~ 31	✓
ZOOM	10	0 ~ 31	✓
BLC	OFF	OFF/ON	✓
FOCUS	AF	AF/MF	✓
Z-SAVE	ON	ON/OFF	✓
F – RANGE	1 ~ 3M	1 ~ 3M/1.0M/3~8M/1~8M	✓
RESET	→		
SAVE - EXIT	→		

The camera module menu uses different buttons to enter, move up and down and edit parameters, as that used for the main PTZ menu that is detailed earlier in this manual.

Using Coaxitron

Enter PTZ Control menu A and select correct channel number. To enter the camera module menu, press the One-touch right arrow twice to display screen B.

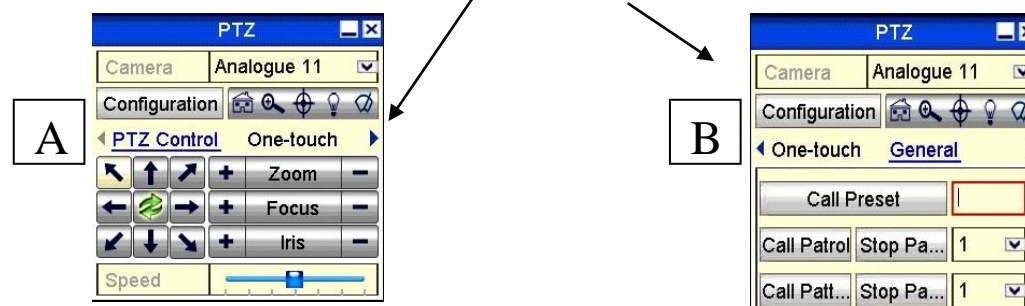

In the Call Preset box enter 91 then Enter, then click Call Preset button; and then enter 80 in the Call Preset box then Enter and click Call Preset button. The camera module menu will be displayed. You will probably need to move the PTZ Control Menu display away from the menu display, so do this by holding down the left mouse button on the blue bar and dragging it away to another position on the screen display. Now click the One-touch left arrow button twice to return to PTZ Control menu A.

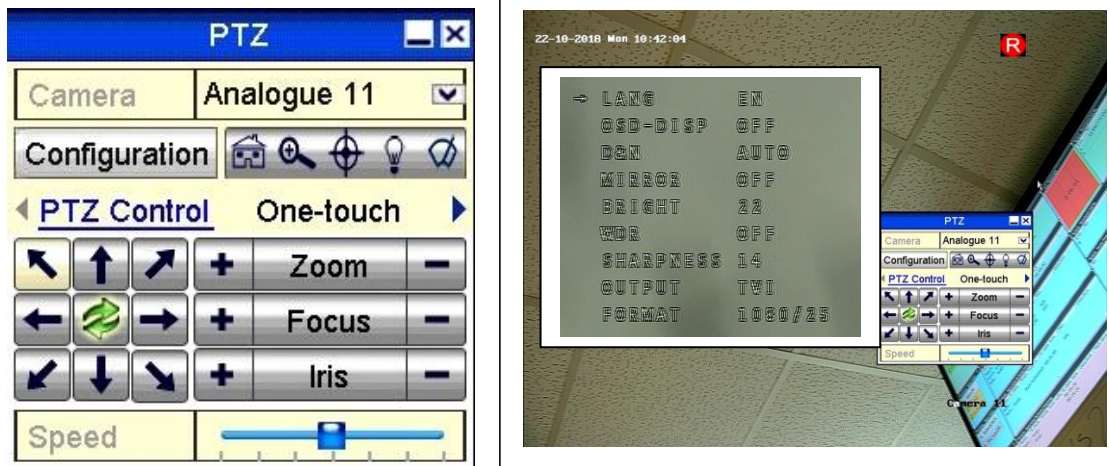

Zoom - moves down the menu
Focus + enters menu settings
 moves left - decreases settings

Zoom + moves up the menu
Focus - exits submenu settings
 moves right - increases value

Example: Need to increase/decrease brightness

1. Enter menu as explained in section above “Using Coaxitron”
2. Click on (**Zoom -**) to move down to **BRIGHT** option.
3. Click on (**Focus -**) to increase brightness by one step or (**+ Focus**) to decrease
4. Click on (**Zoom -**) to move down first page of menu, then through next page to **SAVE - EXIT**
5. Then click on (**Focus +**) to save and exit camera module menu

Using a Keyboard

To enter the camera module menu use the following commands
 <CALL/SHOT> 91 <ENTER> <CALL/SHOT> 80 <ENTER> or
 91 < CALL/SHOT > 80 <CALL/SHOT>

Wide moves down the menu
Near enters/exits menu settings
 increases value - saves changes

Tele moves up the menu
Far exits submenu settings
 decreases value - exits no save

Example: Need to increase/decrease brightness

1. <CALL/SHOT> 91 <ENTER> <CALL/SHOT> 80 <ENTER> or
 91 < CALL/SHOT > 80 <CALL/SHOT>
2. Click on (**Wide**) to move down to **BRIGHT** option.
3. Click on (**Near**) to increase brightness by one step or (**Far**) to decrease
4. Click on (**Wide**) to move down first page of menu, then through next page to **SAVE - EXIT**
5. Then click on (**Near**) to save and exit camera module menu

Camera Module Menu Functions

Function	Default Value	Parameters
LANG	English	English / Chinese
OSD-DISP	No default	OFF – Additional screen info suppressed ON – Displays additional screen info e.g zoom x
D & N	No Default	AUTO – Automatically changes from colour to b/w EXT - External - does not use internal light sensor BW - Stays in black and white continuously COL - Stays in colour continuously. NB if light deficient then may not be able to display in colour
MIRROR	OFF	OFF - No change FLIP - Upside down and left to right UD - Upside down LR - Left to right
BRIGHT	22	Brightness 0 ~ 31
WDR	OFF	OFF - Wide Dynamic Range OFF ON - Wide Dynamic Range ON
SHARPNESS	14	Sharpness 0 ~ 31
OUTPUT	No default	TVI mandatory
FORMAT	No default	1080/25 720/30 720/25
SAT	07	Colour saturation 0 ~ 31
CONTRAST	16	Contrast 0 ~ 31
ZOOM	No default	Zoom 0 ~ 31
BLC	OFF	OFF No Backlight Compensation ON Backlight Compensation switched on
FOCUS	AF MF	AF Auto Focus switched on MF Manual Focus switched on
Z-SAVE	ON	ON Saves Zoom value setting OFF Does not save Zoom value setting
F – RANGE	1 ~ 3M	1 ~ 3M Focus range setting 1.0M Focus range setting 3~8M Focus range setting 1~8M Focus range setting The smaller the focus range the longer it takes to focus. Out of focus pictures can be caused by fast movement speeds with small focus range settings. Either try a wider focus range and/or reduce movement speed.
RESET	→	Click on Near or Iris + to reset and save. Note that there are some options that are not defaulted using Reset so will have to be manually changed.
SAVE - EXIT	→	Click on Near or Iris + save and exit.

System Installation

Dimensions

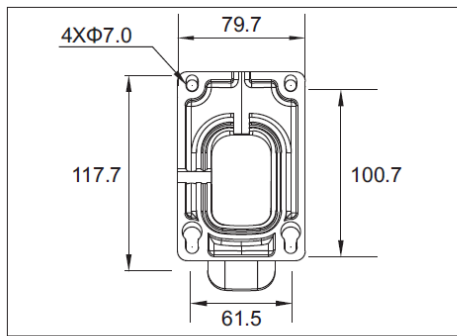

Wall mount bracket

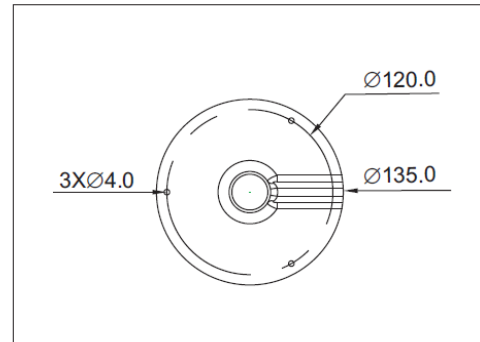

Ceiling mount bracket

Step 1. Draw mounting position holes. Remove bracket from packaging and mark the mounting positions on the wall or ceiling.

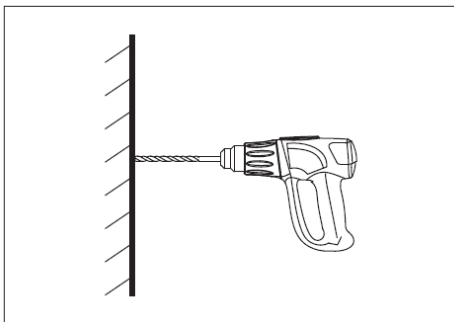

Step 2. Drill mounting holes in wall or ceiling.

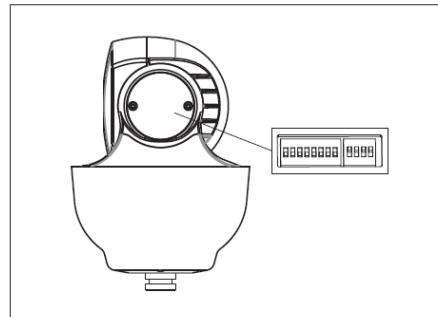
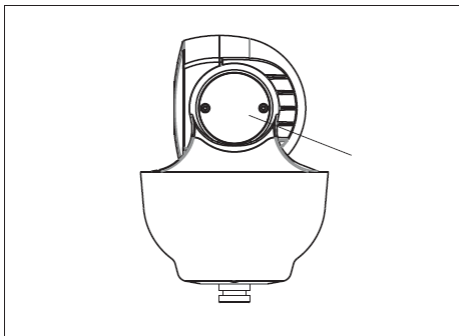

Step 3. Remove the two screws holding the transparent plastic cover over the dipswitches. You will see one bank of 8 dipswitches and one bank of 4 dipswitches. The bank of 8 are for setting the PTZ ID number and the bank of 4 for setting the baud rate and termination. Please refer to the earlier section “Setting up a unique Address and Baud Rate in the PTZM range”. After setting dipswitches replace the transparent plastic cover and screws.

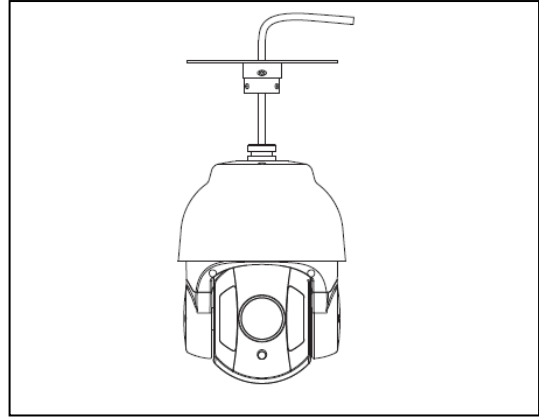
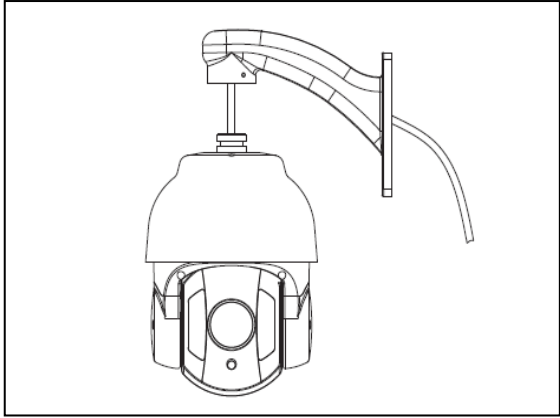

Step 4. Feed cable through wall or ceiling mount bracket.

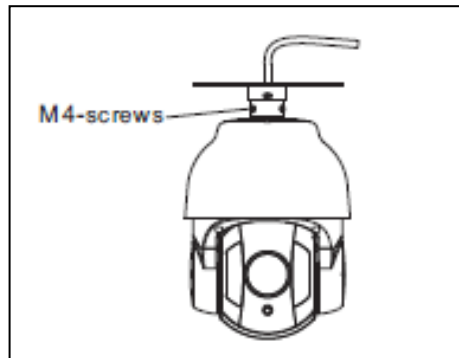
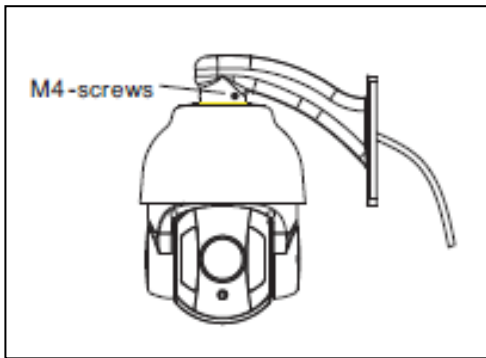

Step 5. Connect dome camera to wall or ceiling bracket using the 4 screws supplied.

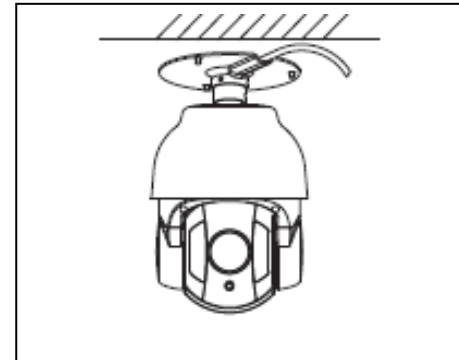
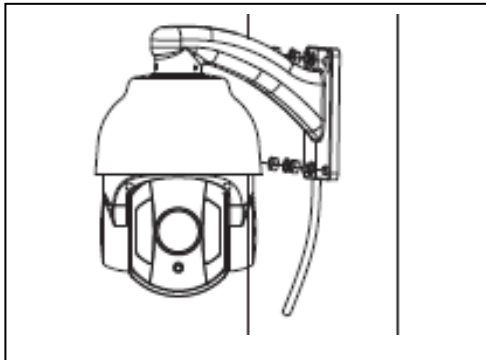

Step 6. Fit PTZ camera to wall or ceiling.

For wall mount, in order to get a good waterproof seal, fit rubber seal on base of bracket and secure the camera using 4 screws as per diagrams above. It is recommended that the port on the bracket used for the PTZ wiring is sealed using silicon sealant.

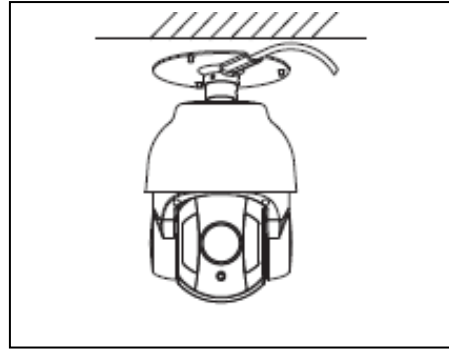
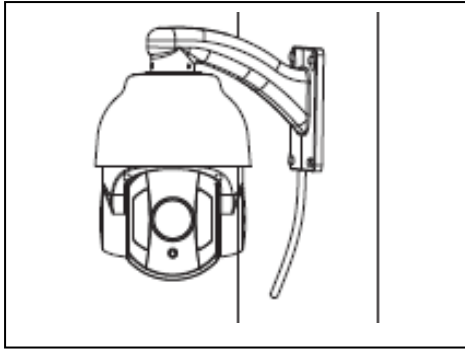

Make sure that the cable enters the camera horizontally or from a lower position so that water does not run down to camera. Also ensure that silicon sealant is used where the cable enters the PTZ camera.

Do not forget to remove the clear protection film on the dome cover as this may cause poor cloudy type pictures.

Alarm Feature

The PTZM400 has 2 alarm inputs. You will need to decide how many alarm channels will be utilised. For each alarm channel you will need a pair of cable connections and it is recommended that a CAT5 twisted pair be utilised. Connect one core to the selected input alarm channel and the other to the appropriate ground (common) connection.

ALARM CABLE

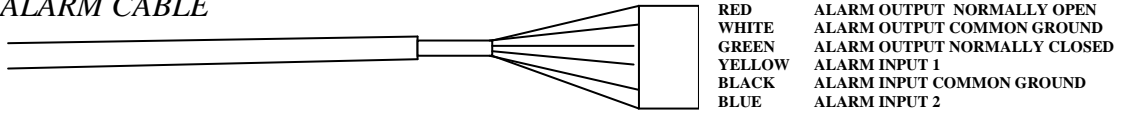

At the alarm end connect to the alarm device. This must be a 0 volt switch and maybe for example a door switch. Check that the alarm device passes a voltage free switch as any other input signal may damage the dome.

Each alarm channel calls a different PTZ operation when the 0v switch is detected by the dome. This allows the dome to immediately action the selected operation in an alarm condition. To set these special operations you need to enter the Alarm menu.

&CHANNEL	001	Channel	1 or 2
ENABLE	OFF	Select the alarm channel 1 or 2	
INPUT	NO	Enable	OFF / ON
OUTPUT	NO	Switch the alarm on or off.	
STAY TIME	060	Input	NC / NO
ACTION	NO	Set alarm for normally closed or normally open connection.	
EXIT			

Output NC / NO

This PTZ has one output alarm either NO (normally open) or NC (normally closed).

Stay time 60 default / FOLLOW / ALWAYS / 1 ~ 240 seconds

Sets the alarm trigger time.

Action NO / Preset 1 ~ 8 / Patrol 1 ~ 8 / Pattern 1 ~ 4 / Auto Scan / AB Scan

Set the alarm option from preset, patrol, pattern, auto scan (continuous 360 degree scan) and AB scan for standard two point auto scan.

When setting an alarm action, if the alarm is triggered it will only go to the preset selected and stay there, or it will initiate the relevant patrol, pattern, auto scan or AB scan. If you do not set FOLLOW then if more than one alarm is triggered during the Stay time, only the first alarm is triggered. If FOLLOW is selected then each alarm will be actioned sequentially.

Note that you can set the Park Action Time in order to return from alarm action to original function but you have to add the Park Action Time to the Stay time before the Park Action is implemented.

Technical Specification

MODEL	PTZM400
Zoom Module	10 x 1080P 4IN1
CCD	1/2.9" CMOS
Colour	PTZM400W - White or PTZM400B - Black
Varifocal Lens	4.7mm-47mm 2.0MP
Video Output	TVI / AHD / CVI / CVBS (1v p~p 75 Ω)
RS485 & Coaxitron	RS485 via cable or Coaxitron UTC using Alien DVR
S/N	≥ 50dB (AGC Off)
Viewing Angle	H: 57.6° (W) ~ 5.8° (T) V: 36.4° (W) ~ 4.3° (T)
Illumination	Colour: 0.1Lux B/W: 0.01Lux
Pan Range	360° endless
Pan Speed	0.1° ~ 200° per second
Tilt Range	0 ~ 90 degrees with auto flip at 0.4° ~ 30° per second
Manual Speed	High, Medium or Low
Proportional Zoom	Supported
Number of Presets	Maximum 220 and 32 per patrol/tour
Number of Patrols/Tours	4/8 depending on call code used
Number of Patterns	4
Auto Scan 360°	Supported
AB Auto Scan	Supported
Park Action	Presets/Patrols/Patterns/Auto Scan 360° / AB Scan
PTZ Position Display	Supported
Alarm	2 alarms
IR number and range	6 High Power LEDs 60m range
Privacy Masking	Not Supported
Menu	English/Chinese
Power Supply	12v DC
Power Consumption	1.7A (LEDs on)
Working Temperature	-20 °C ~ +60 °C
Relative Humidity	≤95 % RH (without condensation)
Weatherproof Rating	IP66
Lightning Protection	TVS3000V lightning protection

All specifications are approximate. nitedevil.com reserves the right to change any product specifications or features without notice. Whilst every effort is made to ensure that these instructions are complete and accurate, nitedevil.com cannot be held responsible in any way for any losses, no matter how they arise, from errors or omissions in these instructions, or the performance or non-performance of the equipment that these instructions refer to.



This symbol on the products and/or accompanying documents means that used electronic equipment must not be mixed with general household waste. For treatment, recovery and recycling please return this unit to your trade supplier or local designated collection point as defined by your local council.

WEE/CG0783S