

the HD-TVI PTZ range

Installation and Operation Manual

SEE-PTZ600 series

SEE-PTZ605 Iridium Silver / SEE-PTZ608 Ivory

***HIGH* Speed PTZ Dome with 3 alarm inputs**

PTZ600 SERIES	Optical Zoom	Total Zoom	Day/Night	IR Sensitive	Minimum Lux	Nite Devil	Focal Length
Option M	30x	360x	YES	YES	0.01 LUX	YES	4.5 ~ 135mm
Option L	23x	276x	YES	YES	0.01 LUX	YES	4.0 ~ 92mm



CONTENTS TABLE

<i>Description</i>	<i>Page No.</i>
Contents	2
Safety Precautions	3
Description of Functions	4
Special Dome Features – 3 channel alarm input activation – Modify Dome address by RS485	5
Getting the PTZ up & running	6
Overview – introduction to fitting PTZ equipment	6
Coaxitron and RS485	8
RS485 Wiring methods & Tips	9
Setting up the Dome Camera	12
RS485 connection – Connecting the Keypad or DVR to the Dome	13
Coaxitron	15
Connecting the video out of the dome	15
If you are using more than one dome on a site	17
Setting up a unique address in a dome	17
Setup of the Protocol and the Default Baud Rate	18
Using the PTZ735 keypad with the PTZ600 series	20
Presets and other functions	21
Patrols (Tours) – How to set them up and use them	22
Auto Scan – How to set it up – Calling the Auto Scan	24
Record Pattern – What is a record pattern?	25
What is the difference between a pattern & a patrol (tour)?	25
How to set it up – Running the Record Pattern	26
Using the M camera module	27
Schedule What is it ? - How to set it up - How to set Schedule – Special Tips	28
Using the Dome’s Advanced Functions	31
Using the Menu System	32
System Setup	33
Display Setup	34
Camera Setup	35
Motion Setup – Presets- Auto Scan - Patrols (Tours) – Patterns – Schedule - Clear	37
Privacy Mask - Using on Alien DVR	41
Advance Setup – Home Setup – Password – CAM ID Setup – Fan Control	42
Advance Setup – Time Set - More - Shortcut Function for M module commands	46
System Reset - Exit	47
Using the M camera module	48
Controlling one camera then another	49
System Installation	50
Alarm Input cable connections	57
3 Channel alarm input activation & single channel alarm output	58
Connecting the Input Alarm devices	58
Connecting the Output Alarm	59
Technical Specification	60
Appendix A: Lightning Proof and Surge Signal Proof	61
Appendix B: General Information – The Cleaning of Dome Cover/Troubleshooting	62

Please read this operation manual carefully
before installing and using this unit !!!!



Please read the following;

1. Please read the operation manual carefully before installing and operating the product.
2. The actual dome requires a 24v AC power supply. The rated input voltage of the camera is 12V!!!! This gets its power from the dome and does not require a separate PSU. Do not connect 24V AC to the camera under any circumstances!!
3. During the course of transportation, storage and installation, the product should be handled with care avoiding vibration and any weight pressure, which may cause damage to the sophisticated optical and electronic equipment inside the machine.
4. Do not attempt to disassemble the camera. In order to prevent electric shock, do not remove screws or covers. There are no user-serviceable parts inside the camera.
5. Always use and stick to current electrical safety standards to install and use the dome. Use a correctly rated power supply. The RS-485 and video signal cables should be kept way from other high voltage equipment such as mains cables and especially fluorescent lights. Using an anti surge protection device is recommended to prevent damage to the domes from lightning and mains surges. Damage to domes by lightning or mains voltage surges is not covered under the domes warranty.
6. Do not operate in areas exceeding the stipulated limitations concerning temperature, humidity and power supply.
7. Do not aim the camera directly towards the sun or an extreme light source whether it is switched on or not. Do not let the camera focus on bright and stationery objects for a long time. Doing either of these may damage the camera.
8. Do not use strong detergents to clean the main body of the camera as these may damage the dome cover or paintwork. Wipe dirt with dry cloth. If needed a *mild* detergent can be used.
9. Operate the dome camera with great care to avoid shock or vibration. If operated incorrectly, the Dome could be damaged.
10. Ensure the dome is not dropped. Never mount the unit on a ceiling that cannot support its weight.
11. If necessary, use a commercial lens cleaning paper to clear the lens windows. Gently wipe the lens window until clean.



WEE/CG0783SS

This symbol on the products and/or accompanying documents means that used electronic equipment must not be mixed with general household waste. For treatment, recovery and recycling please return this unit to your trade supplier or local designated collection point as defined by your local council.

KEY FUNCTIONS

Description of Functions

This intelligent dome camera is a hi-tech CCTV product, which incorporates a high-clarity colour camera. It has a panoramic variable speed PAN/TILT movement, a multifunctional decoder, a character generator and an on-board processor for logic handling. The dome is easy to connect, install, maintain and operate, and has many features. The dome is compact and has a strong structure with a modern and appealing appearance.

1. Integrated Multi-Protocol Decoder

- a. The integrated multifunctional decoder can communicate with 16 different protocols. The baud rate can be independently set allowing compatibility with numerous systems with selectable baud rates from 2400 bps to 19200 bps. Dip switches control the selection of the protocol and baud rate thus making this dome camera easy to set up and use.
- b. This dome uses RS485 serial control and can address from 1 to 1023 cameras using binary addresses.

2. Integrated Speed-Variable PAN/TILT

- a. The dome can turn 360° horizontally and continuously with unlimited positions with an adjustable speed from 0.2° ~ 300° per second and turning 0° ~ 90° vertically with a manual speed from 0° ~ 120° per second.
- b. The dome can run at low speed, low noise, and does not show any picture shake.
- c. The dome has an automatic 180° flip facility and provides panoramic monitoring without any blind spots.
- d. This dome is a high precision unit and maintains preset positions up to $\pm 0.1^\circ$.

3. High Intelligent Settings

- a. This dome can store up to 128 preset positions in non-volatile memory that are not lost with a power failure. Refer to the section “Presets and other functions.”
- b. The dome can scan horizontally between two points and the scan speed can be modified. The dome can scan a range larger or smaller than 180° between any two points with adjustable speed settings. A total of 3 scans can be stored. Refer to the section on “Auto Scan.”
- c. Six sets of tours (patrols) each with 16 preset positions can be programmed. The run speed is adjustable and a schedule available for timed functionality. Refer to the section on “Patrols (Tours).”
- d. The dome camera can simulate a route operated by you within a 120 second interval by utilising the Record Pattern facility. A total of 3 patterns can be stored. Refer to the section on “Record Pattern.”
- e. Proportional pan function. The dome travel speed will depend upon the extent of the zoom coverage. In telephoto zoom mode, the pan and tilt speeds will be slower for a given amount of joystick movement than that in wide zoom mode. This keeps the image from moving too fast on the monitor when there is a large amount of zoom coverage. This slowing down does not occur when going to a preset, but does occur in turbo mode when the high speed zoom is selected. The minimum pan and tilt speeds are 0.1 degree per second at full zoom.
- f. Password Function. Allows access to the menu to be password protected. Default = 111111
- g. Angle Display. Three options for displaying camera angle settings.

-
- h. Software Modify the Dome Address. Allows dome address to be changed through RS485 software (SID).
 - i. Image Effect & Zero Illuminance. Will display when set in B&W mode or manual zero illuminance.
 - j. Angle Display. The dome can display panning, tilt and view angles of the camera.

4. NiteDevil Feature

- a. The M camera module incorporates a (SL) slower shutter speed allowing the camera to see more at low light levels. This camera option is best suited to slow moving scenes or stationary scenes. The module has 30x optical zoom, resolution of 1080P and 4.5 -135mm 2MP varifocal lens. Illumination is at 0.01 Lux.

NOTE that the M module is integrated into the PTZ menu functionality and therefore does not have a separate camera module menu.

5. Special Dome Features

3 channel alarm input activation & single channel alarm output

One of the special features of this dome is that it has three in-built alarm channels to call three independent presets. This means that for example you may have a door contact and when the contact is closed, it sends a 0 volt alarm switch to the dome on one of the three alarm channels. The dome will then call a previously set preset position and lock the camera onto that position. A single channel alarm out, allows the connection of an audible alarm, lighting or other warning device. When more than one alarm input channel is utilised and activated, the dome will switch to the next channel after two seconds. However once an alarm input channel has been activated, the dome will remain locked to the preset position/s and will not resume a patrol, auto scan or a record pattern until the alarm condition is cleared. However the ALARM SETUP options in the dome SYSTEM SETUP menu can be set to return to a home position if necessary. Three alarm channels can call preset positions 1 ~ 50. For example:

Alarm channel 1 could call preset number 10 - Alarm channel 2 preset number 12

Alarm channel 3 preset number 31.

Refer to the instructions under “Physical installation of the dome” for the wiring diagram.

Modify Dome Address by RS485

The Hardware ID (HID) address is set by the dipswitch settings but can be modified by setting the Software ID (SID) address via the menu. The SID is retained over power down. If the HID is altered e.g HID = 003, the SID will also change to 003.

Scheduling Functionality

This PTZ camera incorporates a schedule for editing automatically operations during different time periods. Up to 8 periods per day can be set to run different operations such as moving to preset positions, running different tours, patterns or scans.

Display Options

A PTZ name and/or dome temperature can be displayed in in the PTZ dome menu.

Getting the PTZ up and running!



You **MUST** connect up the PTZ and your control equipment on a workbench or kitchen table before the actual site installation and **CHECK YOU KNOW HOW TO INSTALL IT CORRECTLY!!!!!!!!!!!!!!!!!!!!!!**.

By doing this you can set-up any DIP switches, adjust the camera, and learn about how it operates before taking it to site. This will save you hours of time on-site trying to work out why a particular item doesn't function as you expected it to. There is nothing worse than installing something and then having to take it down to see how to get it working!! Do the learning curve in the comfort of your own premises!!!!

Do you KNOW how to install PTZ equipment that is controlled by RS485 data signals or via Coaxitron?

Overview- introduction to fitting PTZ equipment

Generally speaking, PTZs require four things;

- 1- They require a power supply and a cable to supply this power to the PTZ. The PTZ600 series operates on 24V A.C.
- 2- They require a cable to get the video signal back to the monitor or recording device.
- 3- They require a cable to transmit the "RS485 control signal" from the keypad or DVR to tell the PTZ to pan and tilt etc.
- 4- Alternatively you can control a TVI PTZ using the DVR, by using the coaxitron option through the video cable.

The following diagram indicates the basic cable requirements for a PTZ system.

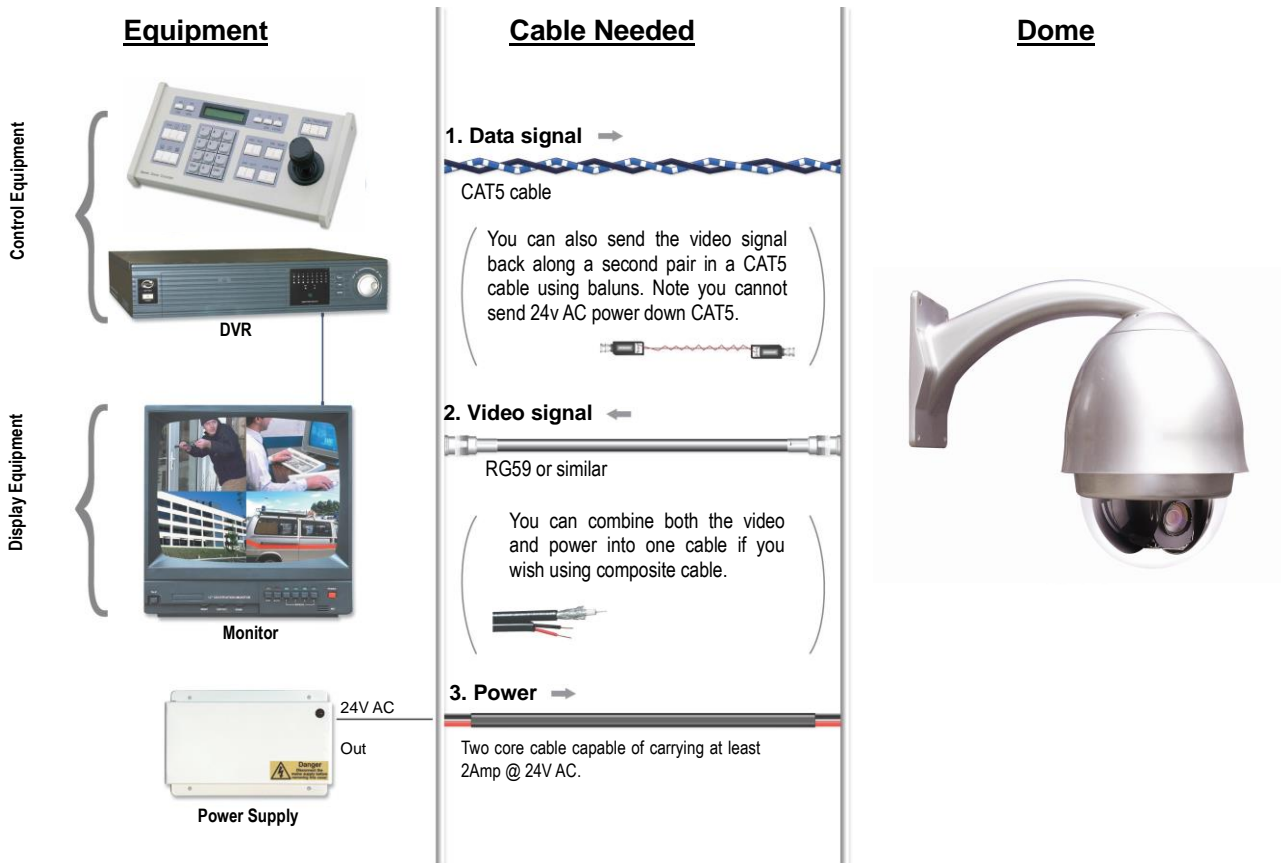

You can get “composite” cables that will carry both the power and the video signals and this has the benefit of combining two of the three cables into one. You may choose to power the PTZ locally to it, so you may only need to get the video signal back from the PTZ and the RS485 control signals to it. If this is the case you may choose to use a pair of HD TVI BALUNS. By using baluns you can send the video signal and control signal down the same CAT5 cable just using different cores for each signal.

The data signal (RS485) is nearly always sent along a “twisted-pair” type cable. The twists in the cable help prevent interference affecting the data signal by “shielding” it. Many installation companies use a CAT5 type or similar cable to run out to the PTZs to carry the data signal. Baluns are not needed for data.

If you are considering using TVI Baluns please note - DVR’s tend to require good video signals to function correctly and will work up to 200 metres on HD. Note there are no active HD baluns available currently. If there is a longer distance needed then standard co-ax cable, shotgun or Combo cable will give up to 500 metres for HD video, but this does not apply to power.

You can mix and match how you wire up your PTZ installation and the following general diagram gives you a guideline about how to do it. Remember this is a GUIDE and is not an instruction what to fit!

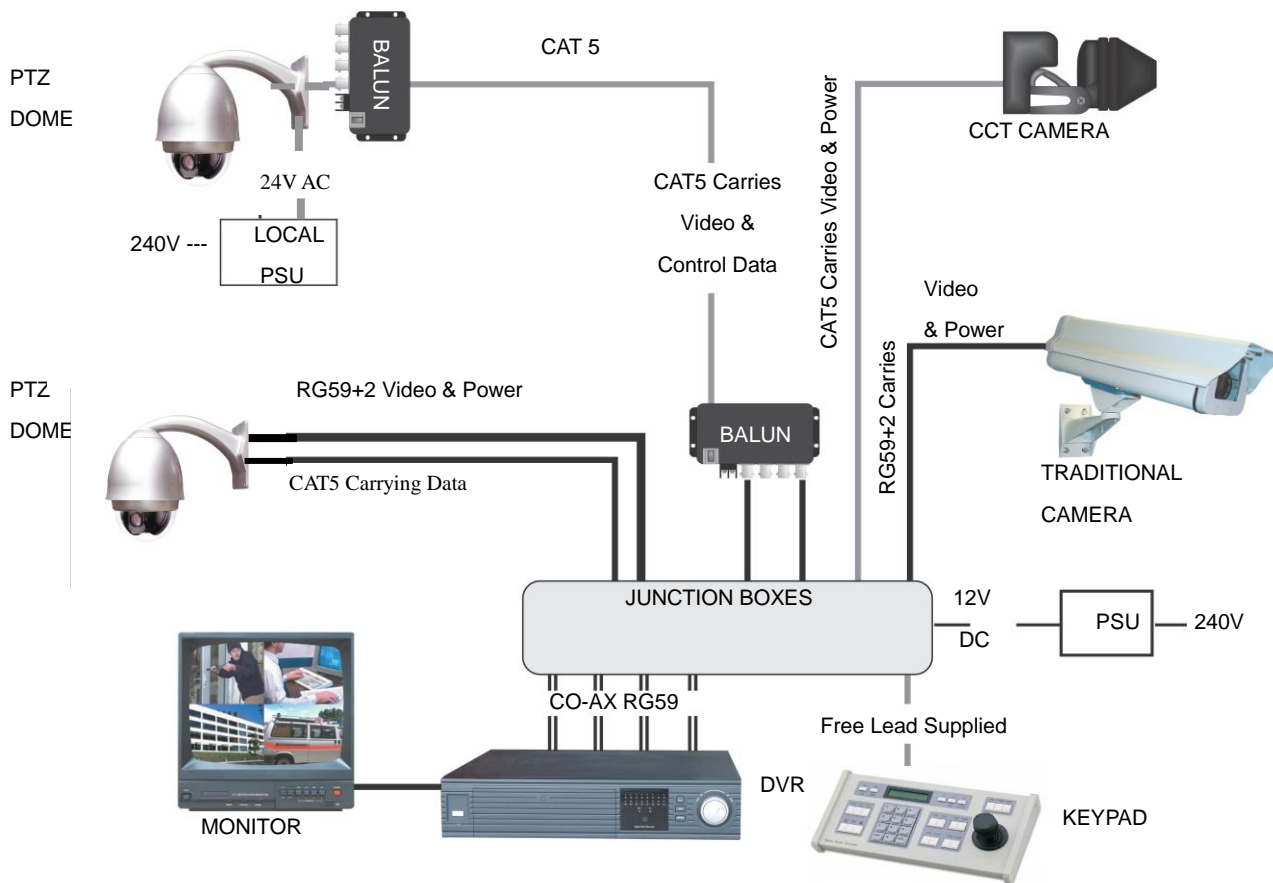

Coaxitron and RS485

These HD TVI PTZ cameras have telemetry control through either the RS485 cable or up the co-ax using the coaxitron facility. The benefit of using coaxitron is that there is no need for an RS485 connection. However PTZ control must be via the DVR and the AlienTVI(Coaxitron) option selected for the relevant camera set in the PTZ menu settings.

If there is a requirement to use a keyboard, the keyboard must be connected via RS485 so the PTZ menu settings must be set with the standard RS485 protocol, baud rate and ID as set in the camera rather than the coaxitron method.

When using the PTZ790 keyboard rather than a standard PTZ keyboard you can use the coaxitron facility via the DVR mode. However you first need to setup the RS485 settings in the DVR PTZ menu ensuring that the baud rate is protocol PELCO-D, baud rate **9600** and ID 01 and save and reboot DVR. Then change the protocol to AlienTVI(Coaxitron) and reboot DVR again.

Many installation companies can get the power and video signal correct, but struggle with the control of the PTZ using the keypad or DVR using the RS485 data.

The key to successfully installing the data cabling to the PTZ is to get the basics right. Use a quality data cable such as CAT5 (never use just a standard untwisted cable such as alarm cable for the RS485 signal).

Also, you must follow the RS485 wiring convention; the following section explains this:

RS485 Wiring methods & Tips >>>>>

1. Characteristics of RS485

As specified by RS485 standards, RS485 is a half-duplex data transmission type with characteristic impedance of $120\ \Omega$. The maximum load capacity is 32 units (domes, keyboards and DVRs).

2. Transmission distances of RS485 Signals using CAT5 or similar cables

Selecting a CAT5 or similar sized twisted pair data transmission cable, the maximum theoretical transmitting distances are as follows:

Baud Rate	<u>Maximum</u> Transmitting Distance
2400 Bps (PELCO-D)	1500m
4800 bps	1000m
9600 bps	600m

PLEASE NOTE - Using inferior cables, or installing the dome in an environment with strong electromagnetic interference, or connecting a lot of PTZ domes to the same cable carrying the RS485 signal will reduce the maximum transmitting distance.

3. RS485 Connection methods

METHOD 1 – DAISY CHAIN CONNECTION.

The general RS485 standard recommends a “daisy chain” connection of equipment that is to be controlled. This means that the control cable is looped out of the one dome to the next dome and so on. The last dome in the line is then fitted with what is known as a “termination resistor”. This has a value of $120\ \Omega$.

The resistor is built in the PTZ domes and is activated by moving the appropriate “jumper” in the dome. The keyboard itself generally has a built-in $120\ \Omega$ resistor. These termination resistors help make the signal more stable and give the system better reliability so the domes function as expected. A common mistake installer’s make is not making sure the $120\ \Omega$ resistor is switched ON in the LAST dome. Also installers often select the resistor to ON in another dome in the chain, these errors will make control of the dome unpredictable.

A simplified Daisy chain is shown below;

This first diagram shows the cables looping in one dome and out of another;

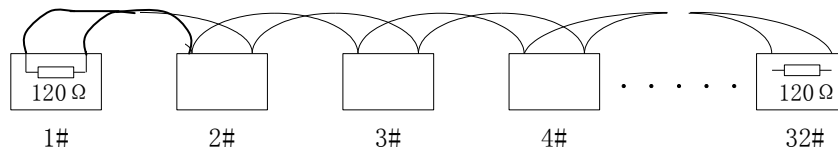

Standard Daisy-Chain connection for the RS485 PTZ control signal

(just the last dome only has the 120 Ω resistor set to on, the first device is the keyboard and has the 120 Ω built in as default)

This next diagram is a slight variation on the Daisy Chain arrangement. Again it's one cable going out to all the domes but instead of the cable going into each dome then back out to the next one, a junction box is used to "Spur-Off" to each dome. Whilst this can be done THE SPUR LENGTH (D) must be NO MORE THAN 10 metres!!!!!!!!!!!!!! The overall cable length between the Controller and the last dome is limited to around 300 metres in such an arrangement.

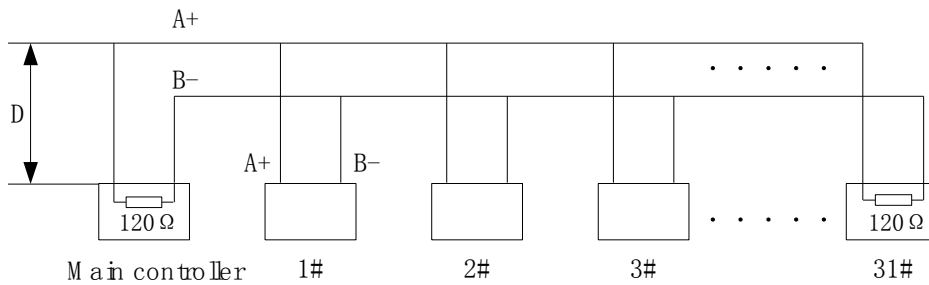

Daisy-Chain connection WITH SHORT SPURS for the RS485 PTZ control signal

(one main radial with very short spurs to each dome off it, keeping the spurs to less than 10 meters)

TIP - The connection of a 120 Ω termination resistor: The termination resistor is ready fitted on the domes pcb, all you have to do set it is move the jumper from Pins 2 &3 to pins 1 & 2.

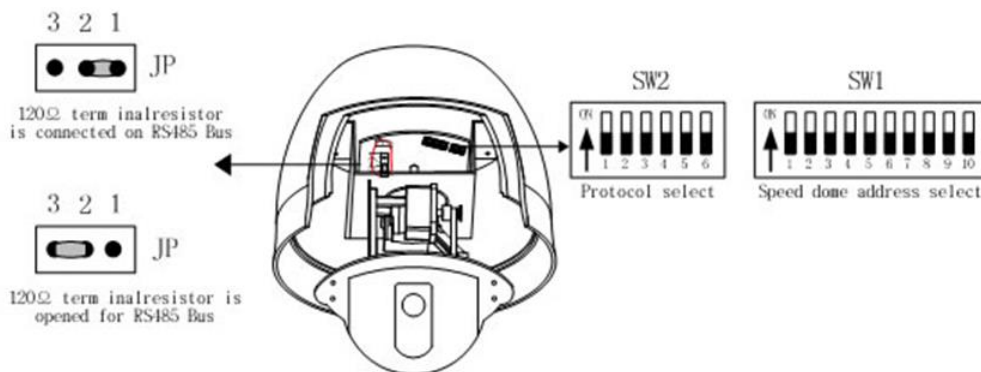

STAR method of connection.

In some circumstances you may need to adopt a star configuration for practical purposes. For instance, all the domes may be so scattered on a large site that running out separate spurs to each dome in a “STAR” array is the only practical solution.

So how do you do this in practice?

The termination resistors must be connected to the two domes that are furthest away from each other, such as domes 3 and 5 in the following “Star diagram”. Note that all the other domes do not have the 120ohm resistor connected. The resistors are already fitted to the domes PCB but by default are not in circuit. To put them in circuit you must move the small “jumper” as previously indicated.

As the star configuration is not in conformity with the requirements of RS485 standards, problems such as signal reflections may arise, especially when there are long cable connections. The results are that control signals are decreased and the dome may not respond to, or just responds intermittently to the controller.

If your STAR circuit is not too extensive with each spur in the region of 20-50 metres you can expect quite good reliable performance using this technique. If you experience any problems though, consider fitting an RS485 distribution box.

The Star circuit for wiring PTZ's.

The two furthest domes need the 120ohm resistors enabling, by moving the “Jumper”
In this example it's domes 3 & 5.

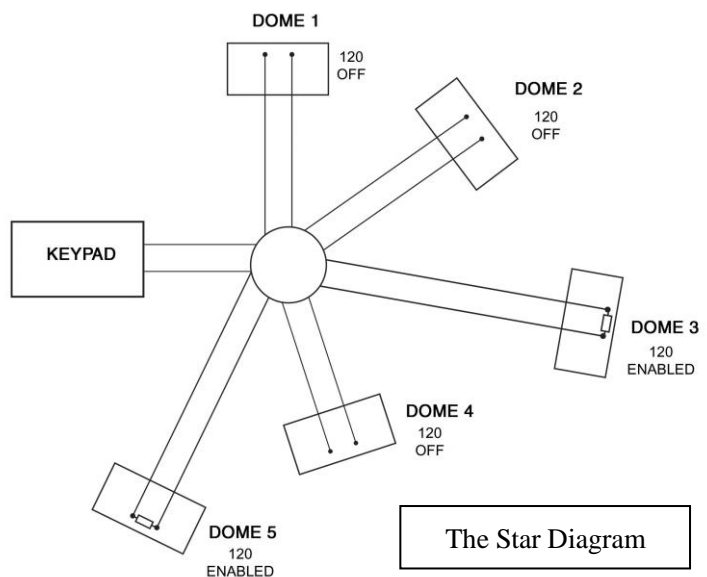

In the real world not everything always works exactly as it's expected to!

RS485 data signals that control the domes' movements are tiny signals that can get corrupted for many reasons. Poor cable quality, not using a PAIR of cores from a CAT5 but using one core from TWO separate pairs, running the CAT5 cable near mains equipment such as fluorescent lighting all will have a detrimental effect on the signal. These are things that you can correct with good installation practices.

Setting up the Dome Camera

1. Connection of the System

There are many ways to wire up a PTZ system.

If you have read the introduction at the beginning of these instructions you should have got a good idea what your options are.

Below is a general schematic diagram showing you some of these options.

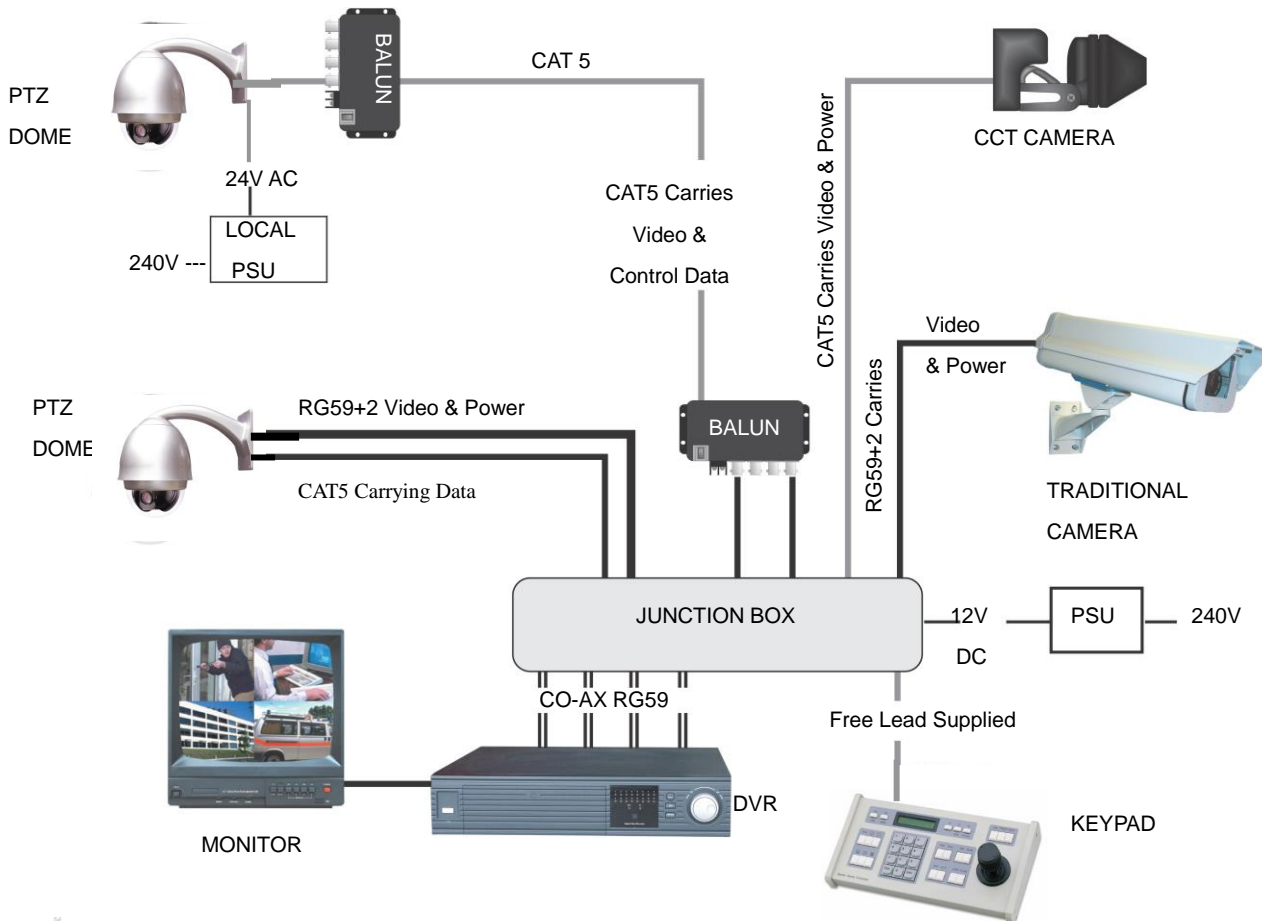

Powering the domes-

All the domes will need power. For this dome it is a 24V A.C power supply. The power supply must be capable of delivering at least **800mA** per dome in normal conditions but it is advisable to allow some extra headroom so that the psu is not running flat out. **It is therefore recommended to use a 24V~30V AC 1.7A PSU (POW999).**

You can either power each dome with its own PSU locally to it or have the PSU's remotely situated perhaps near the keyboard or DVR. The domes require a current of about **950mA** when the heater is on and you must take this into consideration when working out maximum cable runs.

Never put power on CAT5, use the CAT5 + 2. The power cable on CAT5+2 or RG59 + 2 should work up to 80 metres and the Combo power up to 100 metres but in cold weather this will reduce to 70 metres and 90 metres respectively when the PTZ heater kicks in. Otherwise you will need to calculate the correct cable core size for power on longer runs.

Please note - The domes heater doesn't come on until it senses the temperature drops below 0 degrees Celsius. At this point the dome will need up to 1A @ 24V A.C to operate. Please make sure that you have a sufficient power supply and cable installed to cope with this. Obviously the dome may work okay in the summer but when winter kicks in and the dome's current draw jumps from 800mA to 950mA, an inadequate power supply or a cable with too much voltage drop may stop the dome from working properly. When winter comes don't be suddenly caught off guard when your customer rings you to say the dome has suddenly packed in because it's gone cold!!

A popular way to power the domes is using our COMPOSITE VIDEO cable (or shotgun as its also known) as this cable can carry the power to the dome and the video signal back to the monitor or DVR. Alternatively the COMBO cable also provides the additional RS485 data cable.



The power connection

The RED & BLACK cable coming out of the dome connected to the RED terminal block are for power. Connect a suitable 24V A.C power supply to this pair of cores.

The two BNC connectors are for HD and Analogue video outputs. Refer to the label on the outside of the multicore cable for the correct colours either yellow or black to use. The VIDEO-OUT from the camera goes to the monitor or "VIDEO-IN" of a DVR camera input.

The Orange and Yellow pair of cores that go in to the BLACK terminal block are the data cables. These are the cores that carry the RS485 control signal to the dome from either the keyboard or the DVR. The next section of the instructions gives more detail on how to connect the RS485 data. Please also read the RS485 WIRING METHODS & TIPS section towards the beginning of these instructions.

Power cable requirement – Assuming a starting voltage of 24V A.C is applied at the PSU end.

Composite cable	Heater OFF	Heater ON
Maximum run	80mtr	70mtr

The distances are relatively short due to the high load of the dome when it starts up. If the voltage of the dome drops below around 20V A.C it will fail to initialise. Obviously you can power the domes locally if you wish.

RS485 connection - *Connecting the Keypad or DVR to the Dome.*



There are two methods for controlling the PTZ, either by Coaxitron via the DVR or via the conventional RS485 using a PTZ keyboard. If you want to control via the keyboard, RS485 is the best option but you could use the PTZ790 keyboard that allows control through the DVR menu. Whilst this is feasible operations are more difficult as there are more layers of commands to enter.

This section details the RS485 method. The RS485 data signal tells the dome to pan, tilt, zoom etc. Its important that you read the early section of these instructions to understand the fundamental principle of RS485 cabling techniques so that you get it right.

RS485 has two cores, A and B or sometimes known as RS485 + (A) and RS485 – (B) if you get these two the wrong way around then you will not be able to control the dome. Sometimes installers get the connections right on one dome but not on the other and find only one dome works. They then swap the wires around at the keyboard only to find out one dome has now burst in to life and the other one now failed!!

They don't just put 2 + 2 together and realise their mistake that they have wired one dome different to the other. Take great care getting these the right way around and make sure you wire each dome IDENTICALLY so that if you have to swap the A & B lines over at the keyboard you know all domes are wired the same!!

The PTZ600 series adopts the following RS485 convention:

ORANGE = RS485 + or A
YELLOW = RS485 - or B

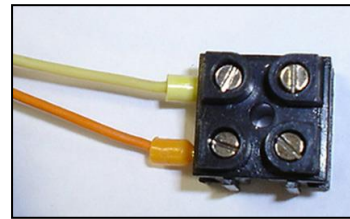

You should initially be wiring the dome to the keyboard or DVR on your workshop bench or at least your kitchen table to prove you know how to get everything to work. Once you have done this, it is just a job of extending the cables and physically installing the domes on site. You must obviously take note of the RS485 wiring techniques mentioned at the beginning of these instructions and get the 120ohm resistors correct in the "End of line" domes. Generally speaking you will always be extending the RS485 signal from either the keypad or the dome using a CAT5 or similar cable. **Note that data cables are not connected through baluns.**

The PTZ735 is one of the keypads that can be used with the PTZ600 range. On the rear of the keypad you will see the RS485 connections. Ensure they are connected correctly i.e the RS485 + Ta line and the RS485 - Tb line as per 1 below.



PTZ735

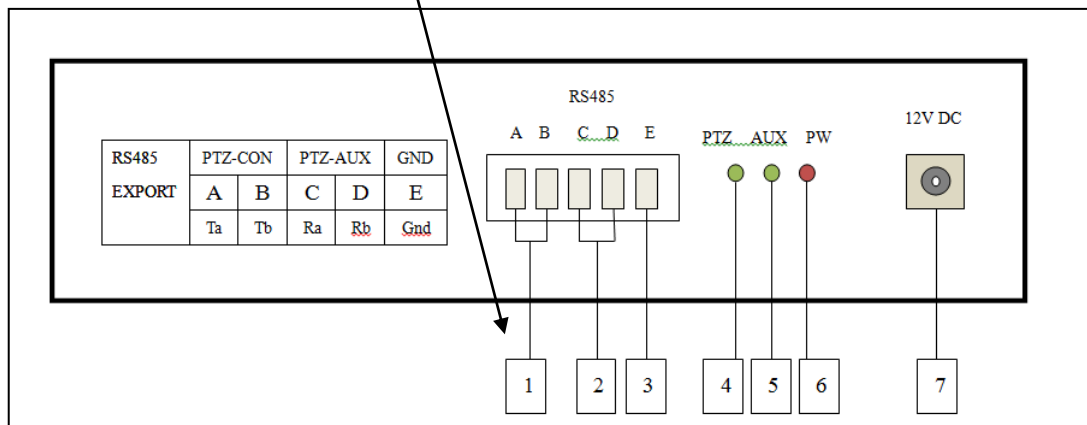

. PTZ-CON Transmit RS485 to PTZ camera Ta = RS485 + Tb = RS485 -

If you use cores from two different pairs in the CAT5 cable you will not get the benefit of the shielding effect of the cable twists and the dome will function erratically. You must always use a core from a PAIR, not two cores from two different pairs!!

Coaxitron – *Accessing the PTZ menu and control via the video cable*

These HD TVI PTZ cameras have telemetry control through either the RS485 cable or up the co-ax using the coaxitron facility. The benefit of using coaxitron is that there is no need for an RS485 connection. However PTZ control must be via the DVR and the AlienTVI(Coaxitron) option selected for the relevant camera set in the PTZ menu settings. Coaxitron will also work with CAT5.

If there is a requirement to use a keyboard, the keyboard must be connected via RS485 so the PTZ menu settings must be set with the standard RS485 protocol, baud rate and ID as set in the camera rather than the coaxitron method.

When using the PTZ790 rather than a standard PTZ keyboard you can use the coaxitron facility via the DVR mode. However you first need to setup the RS485 settings in the DVR PTZ menu ensuring that the baud rate is protocol PELCO-D, baud rate 9600 and ID 01 and save and reboot DVR. Then change the protocol to AlienTVI(Coaxitron) and reboot DVR again.

Connecting the video out of the dome.

The PTZ dome has a multi-core lead of which there are two short BNC leads attached. One has a thick yellow cable and one a thick black cable. A label is attached to the multi-core lead and this details whether the BNC is TVI or CVBS (analogue). You need to extend this lead to the “VIDEO-IN” of the DVR or monitor. Use a good quality RG59 coax cable or similar to do this.

TIP – If you can't get a picture at the remote end you could always take your test monitor to your PTZ dome and check the picture quality on its own short BNC lead.

If you're testing the equipment on a workbench you now have a one dome system. For setting up the keyboard and testing the dome please read sections on default Dome settings and using the keyboard.

You can use a keyboard or a suitable DVR to control the dome. A suitable DVR would be one with PTZ functionality built into it and preferably PELCO-D protocol. If your DVR has a list of protocols it's always best to try PELCO-D first. In the DVR, with PELCO-D set, you should also make sure you set up the baud-rate to 2400.

A typical site installation would look like the following diagram on the next page.

It shows the dome connected to the keypad plus how the dome could also be connected to a DVR instead of the keypad or at the same time. DVR's that have the capabilities of PTZ control will have a terminal or connection on them somewhere, where the dome's RS485+ A and RS485- B line can connect to. Please refer to the individual DVR instructions of how to do this.

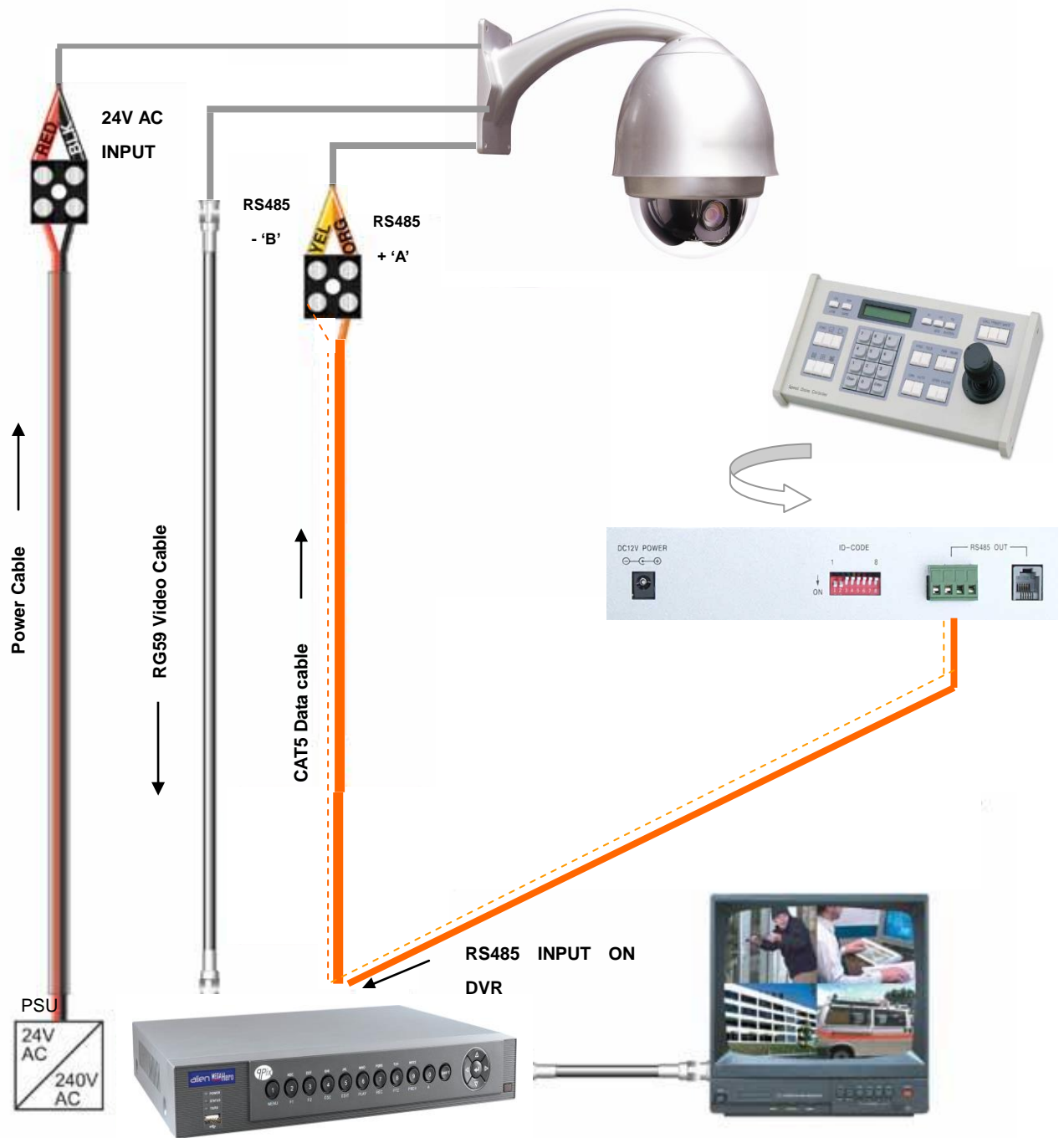

Note that if the DVR has Coaxitron set in the PTZ menu settings, you can use this rather than the RS485 connections shown above. You will need to control the PTZ through the Alien DVR menu.

If you're using more than one dome on a site

Each dome has a unique “address” so that if you are using more than one on a site the keyboard “talks” to the right dome when you want it to PTZ. If you only have the one dome on the site then the default “address” of “1” is okay and you have no reason to change the dome from this.

With multiple dome sites you need to set up each dome address separately. The following diagram shows the switch options. SW2 sets up the protocol. This switch is dealt with later in these instructions.

Special Note:

The jumper and dipswitches are located on the top of the dome head. To access them push the dome module up and twist to release and you will see the switches as per diagram below.

For most System Q equipment they should always be set to PELCO-D 2400 baud rate. In the diagram this is correct. The Jumper on the far right either enables or disables the 120ohm resistor.

Setting up a unique ADDRESS in a dome –

SW1 is used to set address of the dome camera from 1 – 1023.

To set the dome address at 1 put switch 1 up.

To set the dome at address 2 put switch 2 up.

To set the dome at address 3 put switches 1 and 2 up.

..and so on..

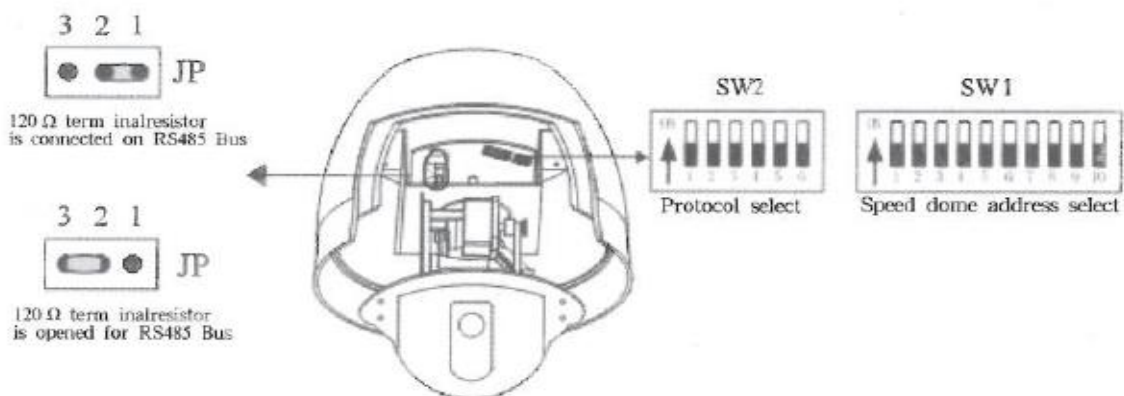

Dome Address	ID-CODE Status									
	DIP-1	DIP-2	DIP-3	DIP-4	DIP-5	DIP-6	DIP-7	DIP-8	DIP-9	DIP-10
1	ON	OFF	OFF	OFF	OFF	OFF	OFF	OFF	OFF	OFF
2	OFF	ON	OFF	OFF	OFF	OFF	OFF	OFF	OFF	OFF
3	ON	ON	OFF	OFF	OFF	OFF	OFF	OFF	OFF	OFF
4	OFF	OFF	ON	OFF	OFF	OFF	OFF	OFF	OFF	OFF
5	ON	OFF	ON	OFF	OFF	OFF	OFF	OFF	OFF	OFF
6	OFF	ON	ON	OFF	OFF	OFF	OFF	OFF	OFF	OFF
7	ON	ON	ON	OFF	OFF	OFF	OFF	OFF	OFF	OFF
8	OFF	OFF	OFF	ON	OFF	OFF	OFF	OFF	OFF	OFF
9	ON	OFF	OFF	ON	OFF	OFF	OFF	OFF	OFF	OFF
10	OFF	ON	OFF	ON	OFF	OFF	OFF	OFF	OFF	OFF
11	ON	ON	OFF	ON	OFF	OFF	OFF	OFF	OFF	OFF
12	OFF	OFF	ON	ON	OFF	OFF	OFF	OFF	OFF	OFF
13	ON	OFF	ON	ON	OFF	OFF	OFF	OFF	OFF	OFF
14	OFF	ON	ON	ON	OFF	OFF	OFF	OFF	OFF	OFF
15	ON	ON	ON	ON	OFF	OFF	OFF	OFF	OFF	OFF
16	OFF	OFF	OFF	OFF	ON	OFF	OFF	OFF	OFF	OFF
17	ON	OFF	OFF	OFF	ON	OFF	OFF	OFF	OFF	OFF
18	OFF	ON	OFF	OFF	ON	OFF	OFF	OFF	OFF	OFF
...
1023	ON	ON	ON	ON	ON	ON	ON	ON	ON	ON

Table 1

2. Setup of the Protocol and the Default Baud Rate.

As shown in Table 2, SW2 is used to set the protocol of communication and the baud rate used by the dome camera. DIP-4 to DIP-1 of SW2 is used to select protocols and a maximum of 16 different protocols can be selected.

PELCO-P/D and 2400 baud rate are generally used in the SEE-PTZ600 systems.

PELCO-P/D 2400 BPS



Protocols	DIP status				Normal Baud Rate	
	DIP-1	DIP-2	DIP-3	DIP-4	DIP-5	DIP-6
B01	ON	OFF	OFF	OFF	OFF	ON
SAMSUNG-1	ON	OFF	OFF	OFF	OFF	ON
Santachi	OFF	ON	OFF	OFF	OFF	ON
PELCO-P/D	ON	ON	OFF	OFF	OFF	OFF
PELCO-M/K	OFF	OFF	ON	OFF	OFF	OFF
PANASONIC	ON	OFF	ON	OFF	OFF	ON
Longcomity	OFF	ON	ON	OFF	OFF	ON
HUNDA600	ON	ON	ON	OFF	OFF	ON
LILIN	OFF	OFF	OFF	ON	OFF	ON
VICON	ON	OFF	OFF	ON	ON	OFF
MOLYNX	OFF	ON	OFF	ON	OFF	ON
KALATEL	ON	ON	OFF	ON	ON	OFF
VCL	OFF	OFF	ON	ON	OFF	ON
SAMSUNG-2	ON	OFF	ON	ON	OFF	ON
ALEC	OFF	ON	ON	ON	OFF	ON
Ultrak	ON	ON	ON	ON	OFF	ON

Some protocols and the states of the coding switches of normal baud rates of these protocols are shown as follows:

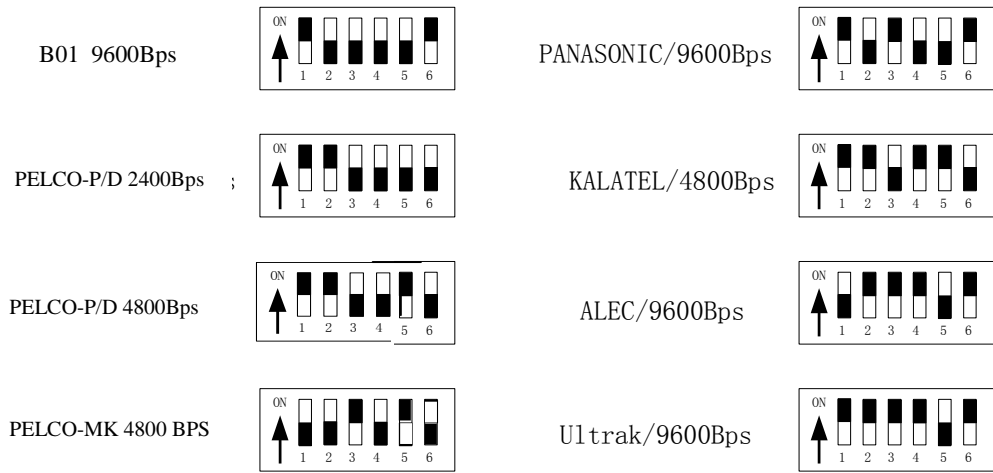

Setup of the Baud Rate of Communication.

As shown in Figure 2, SW2 is used to set the protocol of communication and the baud rate used by the dome camera. DIP-5 and DIP-6 of SW2 are used to select the baud rate of communication and 4 different baud rates can be selected. If the controller adopts a non-standard baud rate, you can adjust it to be identical with that of the controller, as per the following table.

Baud Rate of Communication	DIP-1	DIP-2	DIP-3	DIP-4	Setup of Baud Rate	
					DIP-5	DIP-6
2400bps					OFF	OFF
4800bps					ON	OFF
9600bps					OFF	ON
19200bps					ON	ON

Using the PTZ735 keypad with the PTZ600 series



PTZ735

NOTE 1: For more detailed instructions in setting up the keypad or using one of our other keypads, please refer to the instruction manual supplied with the product.

NOTE 2: The PTZ735 keypad requires you to press the function key first followed by the value e.g <CAM> **01** <Enter> whereas some keypads require the value first, then the function e.g **01** <CAM>

When you first take the keyboard out of the box you will need to set it up for the domes that you are using.

The dome you have purchased has the default settings of PELCO-D 2400-Baud Rate Address 1

RS485	PTZ-CON		PTZ-AUX		GND
EXPORT	A	B	C	D	E
	Ta	Tb	Ra	Rb	Gnd

Rear of PTZ735 keypad

Connect RS485 to Ta and Tb

The RS485 from the PTZ camera must be connected to the back of the PTZ keyboard using the connection A and B in the above diagram. Note that RS485+ = Ta and RS485- = Tb.

These connections are polarity sensitive and will only work provided both keyboard and PTZ camera are same polarity.

First select the required camera number by pressing **Addr <nn> Enter** (where nn = camera no.)

Aim the dome where you want it to look, zoom in or out to get the correct scene and let the camera auto focus. Now press the following keys on the keypad : **PRESET <pp> Enter** (where pp is the preset number you wish to store). For example **PRESET 1 Enter** would set preset 1 and the camera would always go to this location when preset 1 is called using Shot key.

NOTE: The keypad remembers that it is in preset mode.

You can add a number of presets just by entering the

Preset number and Enter providing the LCD displays shows

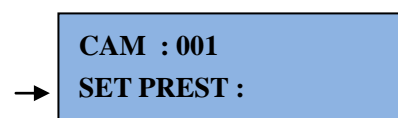

To test if the preset is stored correctly in the dome, use the joystick to move the camera to a point in a new location. Now press **SHOT <ss> Enter** (where xx is the preset you wish the camera to go to). In this example if you press **SHOT 1 Enter** the dome should go straight to the PRESET 1 location.

If you have multiple domes you will need to change the address of each dome so they are different but PLEASE LEAVE THE DOMES ON PELCO-D 2400 BAUD RATE.

- see NOTE 2 above.

PRESETS and other functions.

The dome has up to 128 presets that once programmed with stay in the domes non-volatile memory so they will be retained even after a power cut.

What is a preset? A preset is a particular area or object that the dome was looking at and has been stored into its memory so when the preset is “called-up” the dome will select the area again without the operator using the joystick to do this. Even the zoom at the time is stored into the preset. This means that you could for example store a PRESET of a car-park entrance. When the operator calls up this preset the camera automatically zooms in on this area. By storing more than one preset you can add even more functionality to the dome. By having two presets, you can then get the dome to move between the two locations. You can even vary the speed of this. Note that setting two preset points, the PTZ camera will take the shortest route.

Having 3 or more presets you can get the dome to go on a TOUR (PATROL) of the presets. When you run the patrol the dome goes to one preset, then waits a short period then on to the next preset and so on. The dome continues to cycle around this patrol until you cancel it. The length of time the camera stays at one location and the speed of travel between each preset point can be set in the menu.

PRESETS -How to set up a preset

Aim the dome where you want it to look, zoom in or out to get the correct scene and let the camera auto focus. Now press the following keys on the keypad : <PRESET> + **xx** + <Enter> (where **xx** is the preset number you wish to store). For example <PRESET> **01** <Enter> **would store PRESET 01 and the camera would always go to this location when 01 is <CALLED>.**

To test if the preset is stored correctly use the joystick to move the camera to point in a new location. Now press <CALL> **01** <Enter> (where **xx** is the preset you wish the camera to go to). In this example if you press <CALL> **01** <Enter> the dome should go straight to the PRESET 01 location.

TIP -You may wish to write down a list of presets that you have stored next to the keypad for the operator.

CALLING a preset

This may be as follows;

PRESET 01 = MAIN GATE (a long zoom shot)

PRESET 02 = ENTRANCE DOOR

PRESET 03 = FIRE ESCAPE

PRESET 04 = EMERGENCY EXIT

PRESET 05 = CAR PARK (zoomed-out wide angle)

PRESET 06 = CAR PARK (zoomed-in narrow angle)

When the operator wishes to quickly zoom in on the MAIN GATE all he has to do is press <CALL> **01**<Enter>. To go to the EMERGENCY EXIT he would press <CALL> **04** <Enter> and so on.

To call up any previously stored preset camera location, simply press <CALL> **xx** <Enter>, where **xx** is the preset number.

Patrols (Tours) – How to set them up and use them

A patrol (tour) is simply a collection of preset camera locations that are run in sequence with the dome stopping at each location for a brief period of time and then moving on to the next preset.

For example, you could use a patrol so that an outside dome camera points at a gate, then at a side doorway, then zooms out to get an overall shot of a car park and finally zooming in on a delivery bay, before repeating the whole cycle again. Patrols can be useful for both outside and internal PTZ's. For a shop they could be used to cover key areas like clothes rails, tills and changing rooms in a sequence.

To set up a patrol you need to set up the individual stop points where the camera will pause. These are called *presets*.

An example four preset mini-tour

Setting the presets using the keypad

STEP 1- Using the keypad joystick, move to where you wish to start the tour and then press **<PRESET> 01<Enter>**

STEP 2- Now move to the next location and press **<PRESET> 02 <Enter>**

STEP 3- Now move to the third location and press **<PRESET> 03 <Enter>**

STEP 4- Finally move to where you wish to end the tour and press **<PRESET> 04 <Enter>**

Deleting a preset

You may wish to delete a preset.

You can set up to 128 presets but if you need to change an existing preset just use the **PRESET xx Enter** command (xx = preset number) after moving to the new position. This will overwrite the existing preset.

Alternatively you can enter the menu with **CALL or SHOT 95 Enter** then **MOTION SETUP** then **PRESETS** and select appropriate preset number, you can then move down to **DELETE** to remove it.

Note that if you wish to view the current presets set, go to **MOTION SETUP** then **PATROLS** and then **EDIT PATROL** to display the presets in the various patrols/tours that have been setup.

Setting the Patrol (Tour)

To setup the patrol/tour you need to enter the Advanced Menu System by selecting **<CALL> 95 <Enter>** on the keypad or **<CALL> 64 <Enter>**. (Call varies according to module type). You will see the **Main Menu** displayed on the screen.

Enter the password if switched on, to enter the menu. The Default is **11111**. See **ADVANCE SETUP** menu to change.

Using the joystick up/down direction movement, select the **MOTION SETUP** menu.

Use the joystick pan right movement to enter this menu.

Now use the Joystick up/down direction movement to select **PATROLS**. To the right of this, is the patrol sequence number. By moving the Joystick to the right this number can be increased from 01 to 06 (up to six patrols/tours can be programmed) or decreased using the left direction movement. Start with sequence **01**.

Now select **EDIT PATROL** and press the right button to select edit mode. A table will be displayed showing 16 patrol item numbers. Note that the screen is divided into two halves with two patrol positions per line. Only the odd patrol item numbers are identified down the left hand side of the display.

In the example we are setting four presets in the first patrol sequence.

To edit a patrol sequence

NO Patrol Item No.
POS No. of Preset Position
TM Dwell time at this position
Time 0 ~ 99 seconds

NO	POS	TM	NO	POS	TM
01	001	01	02	002	01
03	003	01	04	004	01
05	---	--	06	---	---
07	---	--	08	---	---
09	---	--	10	---	---
11	---	--	12	---	---
13	---	--	14	---	---
15	---	--	16	---	---

OPEN : NEXT CLOSE : EXIT

Special Note: The patrol item number (**NO**) is an ascending number list of the preset items within this sequence. It may not necessarily reflect the actual preset number. You could for instance have preset item (NO) 01 with preset position 004 as the first preset required.

Enter the preset position number (**POS**) and the dwell time (**TM**) for each preset by using the Joystick up/down movement. Move the Joystick to the right to move to the next field.

After including all the presets required in this patrol/tour, press the Keypad **CLOSE** button to exit. If you add extra presets later and wish to incorporate into a patrol/tour already created, you must add the additional preset positions in the necessary **EDIT PATROL** table sequence.

Now exit the menu by moving the Joystick down, selecting **EXIT** and then moving the Joystick to the right to return to the Main Menu. Again use the Joystick to select **EXIT** and exit the Advanced Menu System by selecting the right pan movement.

Calling the Patrol (Tour)

There are two methods of initiating the patrol or tour. If you enter **<CALL> 65 <Enter>** via the keypad you can initiate patrol/tour sequence 1 only.

Enter <CALL> 65 <Enter> to run Tour 1 or enter <CALL> 66 <Enter> to run Tour 2. Only works if Shortcut set to ON in Advanced menu.

You may also initiate a patrol or tour through the Advanced Menu System.

Enter <CALL> **95** <Enter> or <CALL> **64** <Enter> on the keypad. Enter the password to enter the menu.

The Default password is **111111**. See Advance Setup menu to change.

You will then see the **Main Menu** displayed on the screen.

Using the joystick up/down direction movement, select the **MOTION SETUP** menu.

Use the joystick pan right movement to enter this menu.

Now use the Joystick up/down direction movement to select **PATROLS**. To the right of this, is the patrol sequence number (**xx**). By moving the Joystick to the right this number can be increased from 1 ~ 6 (up to six patrols/tours can be programmed) or decreased using the left direction movement. Now select **RUN PATROL** button to initiate the patrol/tour sequence number.

Special Note: If you notice that some expected presets are not being incorporated in a patrol/tour, check that the PATROL table has been setup correctly and shows all presets for the required sequence. A full explanation of the values to be set can be found in the previous section *Setting the Patrol (Tour)*.

TIP - To stop the PATROL just move the joystick slightly.

AUTO SCAN- How to set it up

Auto-scan scans between two points. These are not presets as per the patrol(tour) facility but auto scan selection points. You may program up to 3 auto scans.

STEP 1 – Select the required camera by pressing the <CAM> button and then entering <camera address> on the keypad.

To setup the Auto Scan you need to enter the Menu System by selecting <CALL> **95** <Enter> or <CALL> **64** <Enter> on the keypad.

Enter the password to enter the menu.

The Default password is **111111**. See Advance Setup menu to change.

You will see the **Main Menu** displayed on the screen.

Using the joystick up/down direction movement, select the **MOTION SETUP** menu.

Use the joystick pan right movement to enter this menu.

In the **AUTO SCAN** menu select the scan number (maximum 3), then the speed (1 – 7). Now position the camera where you wish to start scanning from. Using the joystick select **SET START LIMIT**. Then

press the **CLOSE** button to save the start position.

Now aim the camera where you wish to end the scanning point. Now select the **SET END LIMIT** followed by **CLOSE** button to save.

Calling the Auto Scan

First you must set the start and end positions of the auto scan as above. This runs the auto scan function between these two points. *There are two methods of initiating the auto scan. If you enter **<CALL> 67 <Enter>** via the keypad you can initiate the auto scan. Note that the CALL 67 will run at the speed set in the **AUTO SCAN** table.

***NOTE: Enter <CALL> 67 <Enter> to run Auto Scan 1 or enter <CALL> 68 <Enter> to run Auto Scan 2 (Only works if Shortcut set to ON in Advanced menu).**

You may also initiate the auto scan through the Advanced Menu System. Enter the Main Menu by selecting **<CALL> 95 <Enter>** or **<CALL> 64 <Enter>** on the keypad.

Enter the password to enter the menu.

The Default password is **11111**. See Advance Setup menu to change.

You will see the **Main Menu** displayed on the screen.

Using the joystick up/down direction movement, select the **MOTION SETUP** menu.

Use the joystick pan right movement to enter this menu.

In the **AUTO SCAN** menu select **RUN SCAN**. If the start position is the same as the end position it will do a 360° scan. Now press the **CLOSE** button to save and initiate the Auto Scan.

TIP - To stop the scan just move the joystick slightly.

RECORD PATTERN- What is a record pattern

This dome has an option to store a record pattern. A record pattern consists of a continuous sequence of standard pan and tilt movements or lens commands recorded within a minimum period of 120 second interval. A record pattern does not use presets. You can limit movement at a required position and pan and tilt within the 120 second time restriction. Once the recording is complete, i.e you have closed the recording or the record time has expired, you may use an option in the Motion Setup Menu to replay the recorded pattern. Once this recorded pattern is initiated, the dome will run the record pattern continuously until a keypad movement is detected or an alarm is activated.

RECORD PATTERN- What is the difference between a pattern & a patrol (tour)

A patrol (tour) uses presets and when initiated, the dome will move to a maximum of 16 preset positions using the dwell times as set in the Patrol Table. A patrol (tour) can run for an extensive length of time with a dwell time of a maximum of 99 seconds at each of sixteen preset positions. In

addition up to six different patrols (tours) can be stored each with different preset parameters whereas only three record patterns can be recorded. When a preset is stored the dome stores not only the preset position but also zoom and camera attributes. A record pattern does not record zoom attributes.

A record pattern does not use presets. It however allows the user to record a continuous sequence of standard pan and tilt movements or lens commands but does not allow presets, flip, digital zoom, proportional pan or turbo speed. The record pattern sequence can be recorded using the keypad pan and tilt joystick but will record for a minimum of a 120 second interval. (The actual time will depend on the number of different PTZ movements made by the PTZ camera and the storage space taken). A record pattern allows the user a continuous view rather than selected preset positions and is similar to an auto scan except that an auto scan only allows a selected movement speed whereas the record pattern reflects the user movements made during the recording of the record pattern.

RECORD PATTERN- How to set it up

Record Pattern allows a pattern to be recorded which consists of any standard pan and tilt or lens commands within a minimum time period of 120 seconds. A pattern is automatically closed when the storage space is exceeded or by pressing the CLOSE button. Note that the following are not allowed in a pattern: presets, flip, digital zoom, proportional pan and turbo.

STEP 1 – Select the required camera by pressing the **CAM** button and entering <camera address> followed by <Enter> on the keypad.

Position the camera where you wish to start the record pattern sequence. Enter the Main Menu System by selecting <CALL> **95** <Enter> or <CALL> **64** <Enter> on the keypad.

Enter the password to enter the menu.

The Default password is **111111**. See Advance Setup menu to change.

You will see the **Main Menu** displayed on the screen.

Using the joystick up/down direction movement, select the **MOTION SETUP** menu.

Use the joystick pan right movement to enter this menu.

STEP 2 - In the **PATTERNS** menu select **PATTERN NUMBER** and enter number from 1 ~3 .
Now select **RECORD PATTERN**.

STEP 3 – Now move the camera using the keypad joystick to record for approximately 120 second sequence and follow this by pressing the **CLOSE** button to save. The record pattern will be stored for future replay.

Running the Record Pattern

First you must have recorded a record pattern as detailed above. This runs a record pattern for a minimum of 120 seconds duration. You can run the Record Pattern through the Main Menu. Enter the Main Menu by selecting <CALL> **95** <Enter> or <CALL> **64** <Enter> on the keypad.

***NOTE:** Enter <CALL> **69** <Enter> to run Pattern 1 or enter <CALL> **70** <Enter> to run Pattern 2. Only works if Shortcut set to ON in Advanced menu.

Enter the password to enter the menu.

The Default password is **11111**. See Advance Setup menu to change.

You will see the **Main Menu** displayed on the screen.

Using the joystick up/down direction movement, select the **MOTION SETUP** menu.

Use the joystick pan right movement to enter this menu.

In the **PATTERNS** menu select **RUN PATTERN**. Now press the **CLOSE** button to save and initiate the Pattern sequence. This will run continuously.

TIP - To stop the record pattern just move the joystick slightly.

Using the M camera module

If the M module camera is used, there are different preset functions available. Note that you must have the Shortcut option set to ON in the Advanced menu for all call functions to work.

CALL 1	CALL TWICE FOR MENU			
CALL 64	OPEN PTZ MENU			
CALL 65	START TOUR PRESETS 1-16	PRESET 65		SET PRESETS 1-16 FOR TOUR
CALL 66	START TOUR PRESETS 17-31	PRESET 66		SET PRESETS 17-31 FOR TOUR
CALL 67	RUN AUTOSCAN 1	PRESET 67		SET START OF AUTOSCAN 1
CALL 68	RUN AUTOSCAN 2	PRESET 68		SET END OF AUTOSCAN 1
CALL 69	RUN PATTERN 1	PRESET 69		SET START OF AUTOSCAN 2
CALL 70	RUN PATTERN 2	PRESET 70		SET END OF AUTOSCAN 2
CALL 72	SWITCH TO B/W			
CALL 73	SWITCH TO COLOUR			
CALL 79	SWITCH CAMERA OFF			
CALL 80	SWITCH CAMERA ON			
CALL 94	RESET PTZ CAMERA			
CALL 95	PTZ MENU			

NOTE: There is no camera menu accessible using this camera module.

SCHEDULE - What is it?

The schedule allows you to set an Autoscan, Tour or Pattern from a specified date and time to a specified date and time on a day or days of the week.

SCHEDULE - How to set it up

1. The schedule requires the Time to be set first in the Advance menu.

MAIN MENU	
1.	SYSTEM SETUP
2.	DISPLAY SETUP
3.	CAMERA SETUP
4.	MOTION SETUP
5.	PRIVACY MASK
6.	ADVANCE SETUP
7.	SYSTEM RESET
8.	EXIT

ADVANCE SETUP	
<HOME SETUP>	(1)
<PASSWORD>	(2)
<CAM ID SETUP>	(3)
<FAN CONTROL>	(4)
< TIME SET >	(5)
RESERVED	(6)
<MORE>	(7)
RETURN	

TIME SET*

This is the time setting menu and is used by the SCHEDULE in the MOTION SETUP menu and for display.

DATE FORMAT YMD/MDY/DMY

Select date format required. This can be YY-MM-DD / MM-DD-YY / DD-MM-YY

TIME SET	
DATE FORMAT:	YYMMDD
TIME DISP:	ON
YY-MM-DD:	12-04-30
HH-MM-SS:	13-53-35
SAVE TIME:	
RETURN	

***SPECIAL NOTE: Whilst you can set either of the above formats for display purposes only the YY-MM-DD format is used for the Schedule.**

TIME DISPLAY ON / OFF

If set to ON and after exiting menu, time will be displayed at bottom right of display screen.

YY-MM-DD 00-00-00 Today's Date - Must be set as Year -Month- Day
HH-MM-SS 00-00-00 Current Time - Must be Hours-Minutes-Seconds

SAVE TIME Saves the time **If not Saved the changes will not be applied.**
RETURN Return to the previous menu.

Now go to the **MOTION** menu and select Schedule

2. How to set Schedule

SCHEDULE

Allows a schedule to be selected for controlling what the PTZ is required to do. Ensure Time is set in Advanced menu first. See 1 above.

SCH ID

Select from 1 ~ 8 different schedules. The software requires the highest priority set first.

ENABLED OFF / ON

Set enable to ON for the SCH ID selected.

REPEAT OFF / ON

Switch to ON if same action is to be repeated. You will notice that if you set this to ON no date will be changeable in the TIME menu only the time from and to.

ACTION NONE / 1~3 SCANS / 1~32 PRESETS / 1~6 PATROLS / 1~3 PATTERNS

Select the option required.

<TIME>

START DATE 00 – 00 – 00

END DATE 00 – 00 – 00

This identifies the Year, Month and Day as set in the Advance Setup menu. Only enter in YY-MM-DD format.

START TIME 00 – 00 – 00

END TIME 00 – 00 – 00

This identifies Hours, Minutes and Seconds.

<REPEAT SET>

Select days for the schedule to operate.

SCHEDULE	
SCH ID:	1
ENABLED	ON
REPEAT	OFF
ACTION	1 PATROL
<TIME>	
<REPEAT SET>	
SAVE	
CLEAR	
RETURN	

SCHEDULE TIME	
START DATE	00 – 00 – 00
START TIME	00 – 00 – 00
END DATE	00 – 00 – 00
END TIME	00 – 00 – 00
RETURN	

SCHEDULE DUTY	
SUNDAY	OFF
MONDAY	OFF
TUESDAY	OFF
WEDNESDAY	OFF
THURSDAY	OFF
FRIDAY	OFF
SATURDAY	OFF

SAVE

After making changes to the schedule you must save them or they will not be applied. Note that if the date range is incorrect then it will not be able to save the schedule. The user will be informed with a prompt in the bottom left side of the display screen.

CLEAR

This clears the schedule.

RETURN

This returns to you to the previous menu.

SPECIAL TIPS

If you are using an Alien DVR for controlling the PTZ600 series, the following may help you with setting the Time and Schedule menus but applies to all settings in all menus. Start by selecting the PTZ camera in full screen display in monitoring mode.

1. Right click the mouse and select PTZ option.
2. Left click on Preset and then scroll down to Preset 64 and highlight it then click Call and OK.
3. Use down arrow button and stop on Advance Menu.
4. Click right arrow to enter Advance Setup menu.
5. Use down arrow key and stop on Time Set.
6. Click right arrow key to enter Time Set menu.
7. Select date format using right arrow key.
8. Select down arrow to move to Time Disp. Use right arrow to switch ON or OFF.
9. Use down arrow key to move down to YY-MM-DD.
10. Click on right arrow to access YY and then use up and down arrows to select year.
11. Do the same for MM and DD.
12. When day set press the **Iris** – button to enter complete string of characters.
13. Click down arrow to move to HH-MM-SS and right arrow to enter the hours.
14. Complete changes in menu before entering Motion Schedule menu.

The above extract shows you how to update the Time menu. Use the same methodology for entering the Schedule menu in the Motion menu.

USING THE DOME'S ADVANCED FUNCTIONS-

On Screen Graphics (OSD) –

The SEE-PTZ600 series boasts six patrol (tour) options, an auto scan option and a three record pattern options. All these can be configured using the OSD.

To bring up the camera menu press <CALL> **95** <Enter> or <CALL> **64** <Enter> (varies with module type). Note that entering Preset 01 twice within 4 seconds will also open the menu.

Enter the password to enter the menu.

The Default password is **11111**. See Advance Setup menu to change.

The OSD is then displayed on the screen. You can navigate between the various options using the Joystick control – up to increase and down to decrease – right pan to enter and left pan to exit. You can also use the OPEN button to enter and the CLOSE button to save and exit.

THE MENU SYSTEM

Using the Menu System.

This menu system allows the user to alter the dome menu instruction options and settings using a control keypad. This first page shows the initial main menu page and only describes the general functions. The following pages show the main menu option selected on the left hand side of the page and a breakdown of that menu page on the right hand side of the page.

MAIN MENU

To enter the main menu system press **CALL 95 <Enter>**
or **<CALL> 64 <Enter>**

on the Keypad. Enter the password to enter the menu.

The Default password is **111111**. See Advance Setup to change.

Use the Joystick control pan up or pan down to increase or decrease a value and pan left or pan right to enter a selection.

The OPEN button can also be used to enter a selection and the CLOSE button to exit.

To leave the main menu press EXIT in Main Menu.

MAIN MENU

- 1. SYSTEM SETUP**
- 2. DISPLAY SETUP**
- 3. CAMERA SETUP**
- 4. MOTION SETUP**
- 5. PRIVACY MASK**
- 6. ADVANCE SETUP**
- 7. SYSTEM RESET**
- 8. EXIT**

DESCRIPTION OF MENU OPTIONS

SYSTEM SETUP: Displays System Information – switches auto flip on or off – sets proportional pan speed - selects alarm function on or off – sets action after alarm.

DISPLAY SETUP: Switches camera name display - angle display – preset label display – dome label display - positions of each display.

CAMERA SETUP: D-Zoom on or off – Camera info display – Focus mode - Auto/day/night – BLC on or off – Line Sync – Slow shutter – Automatic exposure – White balance mode – WDR – Exposure compensation.

MOTION SETUP: Set presets – Auto Scan – Patrols – Patterns – Clear options.

PRIVACY MASK: Set Privacy Mask areas and Mask colour.

ADVANCE SETUP: Sets the Home option – Password – Camera ID setup – Fan control temperature – Time – Advance 2 setup - Set North position and Shortcut option to switch on Call commands for the M camera module – Pan Speed.

SYSTEM RESET: To select camera default settings.

EXIT: To exit menu.

To access System Setup press the OPEN button on keypad or move the Joystick to the right. The menu below will be displayed.

MAIN MENU	
1.	SYSTEM SETUP
2.	DISPLAY SETUP
3.	CAMERA SETUP
4.	MOTION SETUP
5.	PRIVACY MASK
6.	ADVANCE SETUP
7.	SYSTEM RESET
8.	EXIT



SYSTEM SETUP	
1.	SYSTEM INFORMATION
2.	FLIP OFF
3.	PRP PAN OFF
4.	RESERVE N/A
5.	<ALARM SETUP> <see below>
6.	RETURN

SYSTEM INFORMATION

This displays system information. Camera s/no., ID, Protocol, Baud Rate, Model, Version Nos.

FLIP ON / OFF

When this is set to ON the PTZ will automatically flip at 180°.

PRP PAN ON / OFF

Proportional Pan Speed function allows speed control dependent on current speed ratio.

RESERVE N/A

Not used.

<ALARM SETUP>

ALARM NO:

Select alarm channel

ACTION:

Select the action following an alarm.

Select from list :- ALM No. = Preset 01 ~ 50, PATROL 1, SCAN 1 or PATT 1.

After 3 seconds of the alarm function clearing, the PTZ will return to original setting.

ALARM SETUP	
1.	ALM NO: 001 ~ 003
2.	ACTION: <see list>
3.	ALARM ON / OFF
4.	RETURN

ALARM ON / OFF

This setting must be switched ON for each alarm channel required.

RETURN

Returns to System Setup menu.

Move the Joystick down to select Display Setup and press the OPEN button or move the Joystick to the right. The menu below will be displayed.

MAIN MENU	
1.	SYSTEM SETUP
2.	DISPLAY SETUP
3.	CAMERA SETUP
4.	MOTION SETUP
5.	PRIVACY MASK
6.	ADVANCE SETUP
7.	SYSTEM RESET
8.	EXIT



DISPLAY SETUP	
<CAMERA ID>	<see 1 below>
<ANGLE DISPLAY>	<see 2 below>
<PRESET LABEL>	<see 3 below>
<DOME LABEL>	<see 4 below>
RETURN	

CAMERA ID (1)	
DIS	ON
POS	BOTT-R
RETURN	

DISPLAY ON/OFF

When set to ON the camera ID will be displayed.

POSITION TOP-L, TOP-R, BOTT-R, BOTT-L

Positions the camera ID on the screen. Choose from TOP-L (top left corner), TOP-R (top right corner), BOTT-R (bottom right) & BOTT-L (bottom left).

ANGLE DISPLAY (2)	
DIS	ON
POS	TOP-R
RETURN	

DISPLAY ON/OFF

When set to ON the angle will be displayed. ONEPUSH displays for 4 seconds only.

POSITION TOP-L, TOP-R, BOTT-R, BOTT-L

Positions the angle display on the screen. Choose from TOP-L (top left corner), TOP-R (top right corner), BOTT-R (bottom right) & BOTT-L (bottom left).

PRESET LABEL (3) DOME LABEL (4)	
DIS	ON
POS	BOTTOM
RETURN	

DISPLAY ON/OFF

When set to ON the PRESET No. or DOME No. will be displayed.

POSITION BOTTOM/TOP

Positions the angle display on the screen. Choose from BOTTOM or TOP

Move the Joystick down to select Camera Setup and press the OPEN button or move the Joystick to the right. The menu below will be displayed.

MAIN MENU	
1.	SYSTEM SETUP
2.	DISPLAY SETUP
3.	CAMERA SETUP
4.	MOTION SETUP
5.	PRIVACY MASK
6.	ADVANCE SETUP
7.	SYSTEM RESET
8.	EXIT

↓

CAMERA SETUP	
D-ZOOM	OFF
DIS	OFF
FOCUS	AF AUTO
ICR	AUTO
BLC	OFF
L-SYNC	OFF
SLSHUT	OFF
<WB/AE SETUP>	
RETURN	

NOTE: The following camera setup options depend on the camera type installed.

D-ZOOM ON / OFF

The digital zoom can be set by switching this to ON.

DISPLAY ON / OFF / N/A

The camera information is displayed if this option set to ON. Note that if camera setting is displayed as N/A it means the camera does not support this feature.

FOCUS MODE MANUAL / A-AUTO / F-AUTO / AF-AUTO / FREEZE

MANUAL/FREEZE – manual iris and focus / freeze

A-AUTO - auto iris

F-AUTO - auto focus

AF-AUTO - auto iris and focus

ICR AUTO / DAY / NIGHT

This option selects AUTO for colour in day and b/w at night

DAY stays in colour mode

NIGHT stays in b/w mode

BLC ON / OFF

This switches on backlight compensation

L-SYNC ON / OFF

Line sync only used for some special cameras.

SLOW SHUTTER ON / OFF

This provides automatic equivalent to NiteDevil feature.

When camera screen is opened in automatic mode, ASS (Automatic Slow Shutter) is displayed on screen. (Only Sony cameras have this function.)

<WB/AE SETUP>

White Balance Mode/Automatic Exposure.

WB/AE SETUP	
AE MD	AUTO
SHUTTER	N/A
WB MD	AUTO
R GAIN	N/A
B GAIN	N/A
WDR MD	OFF
<EXPCOMP SETUP>	
RETURN	

AE MODE MANUAL / AUTO / SHUTTER

Normally set to AUTO.

SHUTTER

Only available if AE MODE is set to SHUTTER **1 ~ 10000**

**WB MODE AUTO / INDOOR / OUTDOOR / ONEPUSH / ATW / MANUAL /
 ODAUTO / SDAUTO / SODIUM**

This option is used to set White Balance mode. Normally set to AUTO.

R GAIN

Only available for pulsing red when WB MODE set to MANUAL.

B GAIN

Only available for pulsing blue when WB MODE set to MANUAL.

WDR MODE ON / OFF

This option switches on Wide Dynamic Range mode.

< EXPCOMP SETUP>

Exposure compensation.

EXPCOMP ON / OFF

Sets exposure compensation

AMOUNT -7 ~ +7

Sets the value of exposure compensation

EXPCOMP SETUP	
EXPCOMP	OFF
AMOUNT	0
RETURN	

RETURN

Return to WB/AE SETUP menu.

Move the Joystick down to select Motion Setup and press the OPEN button or move the Joystick to the right. The menu below will be displayed.



MAIN MENU

1. SYSTEM SETUP
2. DISPLAY SETUP
3. CAMERA SETUP
- 4. MOTION SETUP**
5. PRIVACY MASK
6. ADVANCE SETUP
7. SYSTEM RESET
8. EXIT

MOTION SETUP

<PRESETS> (1)

<AUTOSCAN> (2)

<PATROLS> (3)

<PATTERNS> (4)

<SCHEDULE> (5)

<CLEAR> (6)

EDIT DOME LABEL

RETURN

<PRESETS> (1)

Enter the preset menu.

PRESET NO 01 ~ 128

PIC FZ OFF / ON

EDIT LABEL

This option allows editing of the preset label. The edit label refers to the preset number selected. The PAN LEFT/RIGHT can move the cursor and TILT UP/DOWN can modify the number. Press the CLOSE to save and exit. Up to 10 characters can be specified including 0 ~ 9, A ~ Z and special characters including < = > ? , @ \ + - . /] The first character must be either 0 ~ 9 or A ~ Z. When testing the preset display it will only show NO.XXX and not the label name. CALL, SAVE and DELETE apply to label setup.

PRESETS

PRE NO. 001

PIC FZ OFF

EDIT LABEL

CLR LABEL

CALL

SAVE

DELETE

FOCUS : MANUAL

RETURN

PRESET NO: 01

LABEL: NO LABEL

CLOSE:EXIT

<AUTO SCAN> (2)

This option allows the setting and the running of the Auto Scan.

SCAN NO.

Sets the scanning number. Maximum is 03.

SPEED < 1 ~ 7 >

AUTO SCAN

SCAN NO. 01

SPEED 04

SET START LIMIT

SET END LIMIT

RUN SCAN

CLEAR SCAN

RETURN

SET START LIMIT

To set the start position enter this menu item and then move the joystick to position the camera at the starting position and then press CLOSE to save the start position.

SET END LIMIT

To set the end position select this menu item and then move the joystick to position the camera at the end position and then press CLOSE to save the end position.

RUN SCAN

To run a scan first set the start and end position. Note that if the start and end position are the same the dome will scan 360 degrees. Press CLOSE to exit.

CLEAR SCAN

If you wish to clear the auto scan select this item and then press CLOSE to exit.

<PATROLS> (3)

Enter this menu to set a patrol.
(Also known as tours or sequences)

PATROLS	
PTRL NO.	01
EDIT PATROL	
RUN PATROL	
CLEAR PATROL	
RETURN	

PATROL NO 1 ~ 6

Set the patrol (tour) number

EDIT PATROL

This option allows editing .

NO Preset point number
POS Preset number
TM Time stopping in seconds

NO	POS	TM	NO	POS	TM
01	001	01	02	002	01
03	003	01	04	004	01
05	005	01	06	003	01
07	---	--	08	---	--
09	---	--	10	---	--
11	---	--	12	---	--
13	---	--	14	---	--
15	---	--	16	---	--
OPEN : NEXT			CLOSE : EXIT		

SPECIAL NOTE

Two patrol presets are displayed per line.
--- means no preset set

PATROL NO 1 ~ 6

Relates to patrol number. Maximum 6.
Press Pan LEFT/RIGHT to move cursor
and Tilt UP/DOWN to change data. Then
press CLOSE to save and exit.

RUN PATROL

Click on this menu item and then press CLOSE to start patrol.

CLEAR PATROL

Click to clear a patrol.

RETURN Returns to MOTION SETUP menu.

<PATTERNS> (4)

Allows recording of 3 patterns for up to 1600 movements each lasting for approximately 120 seconds.

RECORD PATTERN

Click on this menu item to start pattern recording and when complete press CLOSE to save.

RUN PATTERN

Start the run of a pattern and exit from the menu.

CLEAR PATTERN

Click on this to clear the pattern.

<CONFIG> This option allows you to select less patterns but more movements so increasing record time. Amend NEW option to select from :-

3 patterns 1600 movements, 2 patterns 2400 movements or 1 pattern 4800 movements.

RETURN

Click on this to return to the MOTION SETUP menu.

<SCHEDULE> (5)

Allows a schedule to be selected for controlling what the PTZ is required to do

SCH ID

Select from 1 ~ 8 different schedules

ENABLED OFF / ON

Enable respective schedule selected

REPEAT OFF / ON

Select ON if no time applicable

ACTION NONE / 1~3 SCANS / 1~32 PRESETS / 1~6 PATROLS / 1~3 PATTERNS

PATTERNS	
PATT NO.	01
RECORD PATTERN	
RUN PATTERN	
CLEAR PATTERN	
<CONFIG>	
RETURN	

PATTERNS CONFIG	
OLD :	1600 3
NEW :	4800 1
SAVE RETURN	
CANCEL RETURN	

SCHEDULE	
SCH ID:	1
ENABLED	OFF
REPEAT	OFF
ACTION	NONE
<TIME>	
<REPEAT SET>	
SAVE	
CLEAR	
RETURN	

<TIME>

START DATE 00 – 00 – 00

END DATE 00 – 00 – 00

This identifies the day, month or year according to the format set in Advance Setup in Time Set – YMD / MDY / DMY

START TIME 00 – 00 – 00

END TIME 00 – 00 – 00

This identifies Hours, Minutes and Seconds.

SCHEDULE TIME

ST DATE 00 – 00 – 00

ST TIME 00 – 00 – 00

EN DATE 00 – 00 – 00

EN TIME 00 – 00 – 00

RETURN

<REPEAT SET>

Select days for the schedule to operate.

SAVE

After making changes to the schedule you must save them or they will not be applied.

Note that if the date range is incorrect then it will not be able to save the schedule. The user will be informed with a prompt in the bottom left side of the display screen.

SCHEDULE DUTY

SUN OFF

MON OFF

TUE OFF

WED OFF

THU OFF

FRI OFF

SAT OFF

CLEAR

This clears the schedule. **RETURN** This returns to you to the previous menu.

<CLEAR> (6)

This option clears all options.

CLEAR ALL PRELABEL Clears all presets.

CLEAR ALL SCAN Clears all scans.

CLEAR ALL PATROLS Clears all patrols.

CLEAR ALL PATTERNS Clears all patterns.

RETURN Returns to MOTION SETUP menu.

EDIT DOME LABEL This options allows editing of Dome Label. Refer to EDIT LABEL in PRESETS menu for details. The label is made up of 10 characters.

RETURN Return to main menu.

CLEAR

CLEAR ALL PRELABEL

CLEAR ALL SCAN

CLEAR ALL PATROLS

CLEAR ALL PATTERNS

RETURN

MAIN MENU	
1.	SYSTEM SETUP
2.	DISPLAY SETUP
3.	CAMERA SETUP
4.	MOTION SETUP
5.	PRIVACY MASK
6.	ADVANCE SETUP
7.	SYSTEM RESET
8.	EXIT

PRIVACY MASK	
PRIVACY MASK	01
MASK SHADE	WHITE
DISPLAY	ON
EDIT MASK	
RETURN	

The feature is available on the camera module type “M”.

PRIVACY MASK 01 ~ 08 (Up to 8 privacy mask areas to be set)

MASK SHADE This allows the colour (white, grey or black) of the mask area to be set.

DISPLAY ON / OFF This option can switch on or off the privacy mask function

EDIT MASK This option allows editing of the mask area.

MEGA DVR Right click mouse button and left click on Preset Control. Now click black arrow head, to right of One-touch, twice. Click in the blank box to the right of Call Preset and select 95 from drop down box, click Enter and the press CALL Preset. The PTZ menu will now appear. Move the PTZ control box out of the view of the menu by holding down left mouse button whilst positioning cursor on blue line at top of PTZ box and dragging box from centre of screen.

Now click the right arrow to the left of One-touch in the PTZ Control box twice. Now using the down arrow key, move down the Main Menu to PRIVACY MASK and press right arrow key to access the PRIVACY MASK menu. Select Privacy Mask area number from 01 – 08, select shade (Black, White or Grey), switch display on and enter EDIT MASK using down and right arrow direction keys. You can now see some hyphens in centre of screen. If you use the arrow keys, position these marks so they sit in the centre of the area to be masked then press IRIS minus button. Then press ZOOM minus to enlarge width of masked area and FOCUS minus to increase height. Then press IRIS minus to exit, move down with direction button and right button to exit, then exit.

Keypad Enter menu with CALL 95 and using joystick move down to Privacy Masking. Move joystick right to enter option. Select Privacy Mask area number from 01 – 08, select shade (Black, White or Grey), switch display on and enter EDIT MASK using joystick direction keys. You can now see some hyphens in centre of screen. If you use the arrow keys, position these marks so they sit in the centre of the area to be masked then press IRIS minus button. Then press ZOOM minus to enlarge width of masked area and FOCUS minus to increase height. Then press IRIS minus to exit, move down with direction button and right button to exit, then exit.

RETURN Click to return to main menu.

MAIN MENU	
1.	SYSTEM SETUP
2.	DISPLAY SETUP
3.	CAMERA SETUP
4.	MOTION SETUP
5.	PRIVACY MASK
6.	ADVANCE SETUP
7.	SYSTEM RESET
8.	EXIT

ADVANCE SETUP	
<HOME SETUP>	(1)
<PASSWORD>	(2)
<CAM ID SETUP>	(3)
<FAN CONTROL>	(4)
<TIME SET>	(5)
RESERVED	(6)
<MORE>	(7)
RETURN	

<HOME SETUP> (1)

This option must not be confused with the Alarm function that can be set with different timing settings.

ENABLE ON / OFF

If the AUTO HOME is set to ON the dome camera will revert to the home position without any action in the PARK TIME.

HOME SETUP	
ENABLE	OFF
ACTION	01
TIME	01 MIN
PWR RES	ON
RETURN	

HOME ACTION 01 ~ 50 (preset no.) / PATROL n / SCAN n / PATTERN n / RESUME

This is used to set the auto home action. For example this option will restart a patrol, auto scan, pattern or move to a specific preset point if the current action is interrupted e.g manual movement of the joystick, reboot etc. Resume returns to the position prior to manual intervention.

TIME nn

Park Time sets the wait time duration for the dome. The time can be set from 01 ~ 99 minutes.

PWR RES ON / OFF

If Power Resume is set to ON the dome camera will resume the operation that it was handling prior to loss of power.

RETURN

This returns to the Advance Setup menu.

MAIN MENU	
1.	SYSTEM SETUP
2.	DISPLAY SETUP
3.	CAMERA SETUP
4.	MOTION SETUP
5.	PRIVACY MASK
6.	ADVANCE SETUP
7.	SYSTEM RESET
8.	EXIT

ADVANCE SETUP	
<HOME SETUP>	(1)
< PASSWORD >	(2)
<CAM ID SETUP>	(3)
<FAN CONTROL>	(4)
<TIME SET>	(5)
RESERVED	(6)
<MORE>	(7)
RETURN	

PASSWORD (2)

This option allows password protection.

PASSWORD ON / OFF

If this is set to ON password protection is Initiated. The default password is **111111**

NEW PSW nnnnnn

This is for entering a new password. 6 character numeric field.

CON PSW nnnnnn

This is to confirm the new password.

RETURN

This returns to the ADVANCE SETUP menu.

PASSWORD	
PWD	OFF
NEW PSW	* * * * *
CON PSW	* * * * *
RETURN	

MAIN MENU	
1.	SYSTEM SETUP
2.	DISPLAY SETUP
3.	CAMERA SETUP
4.	MOTION SETUP
5.	PRIVACY MASK
6.	ADVANCE SETUP
7.	SYSTEM RESET
8.	EXIT

ADVANCE SETUP	
<HOME SETUP>	(1)
<PASSWORD>	(2)
<CAM ID SETUP>	(3)
<FAN CONTROL>	(4)
<TIME SET>	(5)
RESERVED	(6)
<MORE>	(7)
RETURN	

CAM ID SETUP (3)

This enters the software ID settings menu

CM S/N:

Displays the dome series number

INPUT S/N:

Inputs the dome series number.

***OLD ID:**

Displays the old dome address.

NEW ID:

Displays the new dome address. Input the series number before inputting the new address.

SAVE & RETURN

To save and return to the ADVANCE SETUP menu.

CANCEL & RETURN

To cancel and return to the ADVANCE SETUP menu.

***ID CHANGE**

This is the long distance dome address setting. The Camera serial number is a 7 bit non-modifiable Serial number. Set the Input Serial number to the same as the Camera serial number using the joystick. The OLD ID known as the HID (Hardware ID) displays the old dome address and is non-modifiable. The NEW ID known as the SID (Software ID) is the new dome address.

Note that if the INPUT S/N is not correctly entered in advance of this entry, an error “S/N ERROR!” will be displayed at bottom of display screen. Also the dome ID address range allows 1 ~ 999 to be addressed but different protocols limit the software (SID) addressable range. The PELCO protocol allows the 1 ~ 255 (SID) address range to be allocated. To specify an address outside this range, set the address using the HID (dipswitch) and power down then up. The dome will then set the HID = SID. Save & Return saves the new setting and returns to the previous menu or Cancel & Return does not save the setting and returns to the previous menu.

CAM ID SETUP	
CM S/N:	11000000
IN S/N:	00000000
OLD ID	001
NEW ID	001
SAVE	RETURN
CANCEL	RETURN

MAIN MENU

1. SYSTEM SETUP
2. DISPLAY SETUP
3. CAMERA SETUP
4. MOTION SETUP
5. PRIVACY MASK
- 6. ADVANCE SETUP**
7. SYSTEM RESET
8. EXIT

ADVANCE SETUP

- <HOME SETUP> (1)
- <PASSWORD> (2)
- <CAM ID SETUP> (3)
- <FAN CONTROL> (4)**
- <TIME SET> (5)
- RESERVED (6)
- <MORE> (7)
- RETURN

FAN CONTROL (4)

To set the fan control menu settings.

SWITCH FAN ON / OFF / AUTO

The fan working conditions can be set. Setting to ON will set fan running and OFF will switch fan off.

If set to AUTO the working temperature of the fan can be set in ON TEMP.

FAN CONTROL

FAN	AUTO
ON TEMP:	40
DISPLAY	OFF
RETURN	

ON TEMP: m

Allows the working temperature of the fan to be set if FAN option is set to AUTO. Temperature adjustable between 28°C to 55°C. Default 40°C.

DISPLAY ON / OFF

If set to ON the temperature of dome will be displayed.

RETURN

Return to ADVANCE MENU setup.

MAIN MENU	
1.	SYSTEM SETUP
2.	DISPLAY SETUP
3.	CAMERA SETUP
4.	MOTION SETUP
5.	PRIVACY MASK
6.	ADVANCE SETUP
7.	SYSTEM RESET
8.	EXIT

ADVANCE SETUP	
<HOME SETUP>	(1)
<PASSWORD>	(2)
<CAM ID SETUP>	(3)
<FAN CONTROL>	(4)
< TIME SET >	(5)
RESERVED	(6)
<MORE>	(7)
RETURN	

TIME SET

This is the time setting menu and is used by the SCHEDULE in the MOTION SETUP menu.

FORMAT

YYMMDD / MMDDYY / DDMMYY

DISPLAY ON / OFF

If time display set to ON and after exiting menu, time will be displayed at bottom right of display screen.

TIME SET	
FORMAT:	YYMMDD
DISPLAY:	ON
Y-M-D:	16-02-01
H-M-S:	13:53:35
SAVE TIME:	
RETURN	

YY-MM-DD **00-00-00** Set as required.

HH-MM-SS **00-00-00** Set as required.

SAVE TIME Save the time.

RETURN Return to the previous menu.

MORE

Select this option to provide the following:

Language English or Chinese -

Set North position -

Shortcut for Camera M module commands -

Pan Speed change

Click on More to display Advance Setup 2

ADVANCE SETUP	
<HOME SETUP>	(1)
<PASSWORD>	(2)
<CAM ID SETUP>	(3)
<FAN CONTROL>	(4)
<TIME SET>	(5)
RESERVED	(6)
< MORE >	(7)
RETURN	

LANGUAGE (1)

Set English or Chinese

SET NORTH (2)

Set direction for calculating Privacy Mask

SHORTCUT (3)

Set ON if you have the SONY N camera module.

This option allows the user to start a Tour, Autoscan or Pattern using a keyboard or DVR with PTZ control. The following CALL commands can be used:

CALL PRESET 1 in quick succession to open menu

CALL PRESET 64 open menu

CALL PRESET 65 run Tour 1

CALL PRESET 66 run Tour 2

CALL PRESET 67 run Autoscan 1

CALL PRESET 68 run Autoscan 2

CALL PRESET 69 run Pattern 1

CALL PRESET 70 run Pattern 2

ADVANCE SETUP2	
LANG:	ENG (1)
SET NORTH:	(2)
SHRTCUT:	OFF / ON (3)
PAN SPEED	150 (4)
RETURN	

SET PRESET 67 Set start of AutoScan 1

SET PRESET 68 Set end of AutoScan 1

SET PRESET 69 Set start of AutoScan 2

SET PRESET 70 Set end of AutoScan 2

PAN SPEED 100, 150, 200, 250, 300°/s

Set the horizontal pan speed

RETURN

Return to ADVANCE SETUP setup.

MAIN MENU
1. SYSTEM SETUP
2. DISPLAY SETUP
3. CAMERA SETUP
4. MOTION SETUP
5. PRIVACY MASK
6. ADVANCE SETUP
7. SYSTEM RESET
8. EXIT

SYSTEM RESET

Selecting this option resets the PTZ menu.

The dome will undertake a self test after it undertakes the reset. The following functions are reset: Auto Flip on, PTZ SPD Rate on, ID Display on, Angle Display off, Dome Label Display Off, D-Zoom Off, PT Interlock – AF Auto, BLC off, Auto Home off, Park Time 4 mins, Fan Auto, Temp Display off.

EXIT

Exit the main menu.

Using the M camera module

If the M module camera is used, there are different preset functions available. Note that you must have the Shortcut option set to ON in the Advanced menu for all call functions to work.

CALL 1	CALL TWICE FOR MENU			
CALL 64	OPEN PTZ MENU			
CALL 65	START TOUR PRESETS 1-16	PRESET 65	SET PRESETS 1-16 FOR TOUR	
CALL 66	START TOUR PRESETS 17-31	PRESET 66	SET PRESETS 17-31 FOR TOUR	
CALL 67	RUN AUTOSCAN 1	PRESET 67	SET START OF AUTOSCAN 1	
CALL 68	RUN AUTOSCAN 2	PRESET 68	SET END OF AUTOSCAN 1	
CALL 69	RUN PATTERN 1	PRESET 69	SET START OF AUTOSCAN 2	
CALL 70	RUN PATTERN 2	PRESET 70	SET END OF AUTOSCAN 2	
CALL 72	SWITCH TO B/W			
CALL 73	SWITCH TO COLOUR			
CALL 79	SWITCH CAMERA OFF			
CALL 80	SWITCH CAMERA ON			
CALL 94	RESET PTZ CAMERA			
CALL 95	PTZ MENU			

NOTE: There is no camera menu accessible using the M camera module.

Controlling one camera then another.

If you look at the image of the LCD display you can see the CAM=001 indicates that the keyboard is ready to talk to camera with address 1. In the dome the address 1 is set as default in the factory. You need to alter the DIP-switches within the domes to address 2, 3 etc if you have multiple domes on the same site, refer to the previous instructions how to set the DIP Switches. If you have another dome set at camera address 2, press CAM followed by 2. This would change the screen to CAM=002. And so on.



Note that it is possible on this dome to change the dome address remotely using the dome menu. Refer to earlier instructions.

System Installation

1. Type of Installation

a) Wall Installation

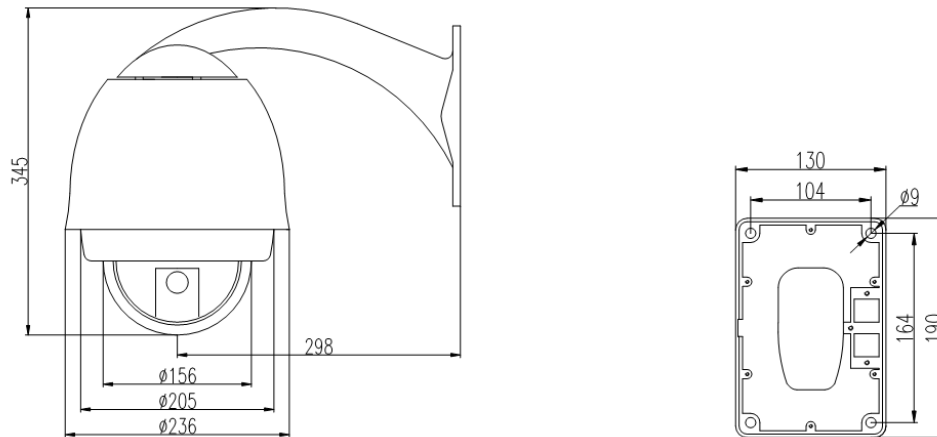

Figure 1

b) Ceiling Installation

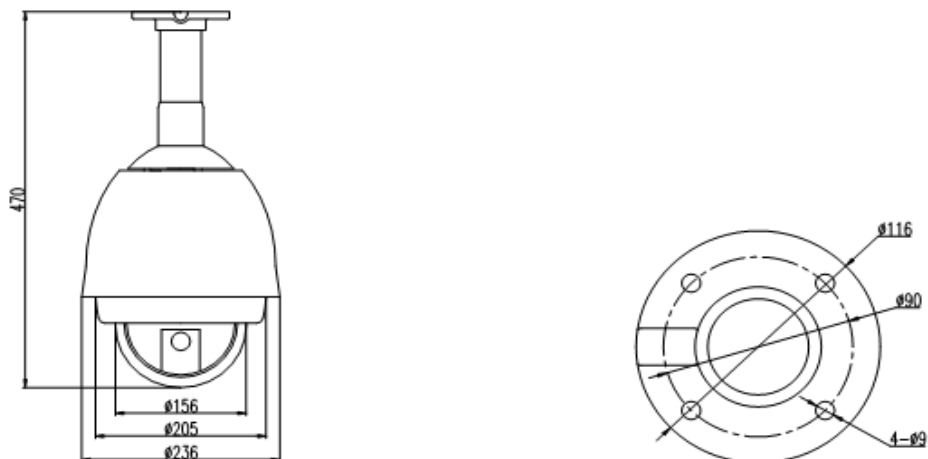
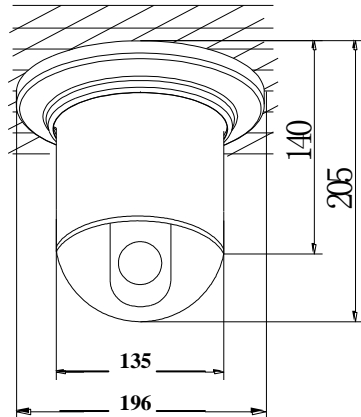
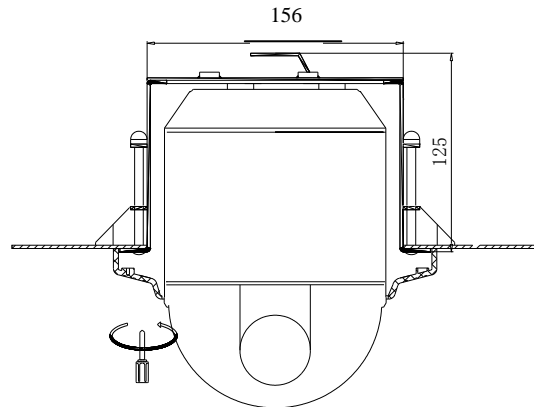

Figure 2

c) Indoor Ceiling Installation (Figure 3)



Indoor Embedded Installation (Figure 4)



2. Installation Procedure (using wall installation as an example)

Preparation before installation --- Dome settings

- a) Turn the dome cover anti-clockwise (Figure 5) and remove it (Figure 6).

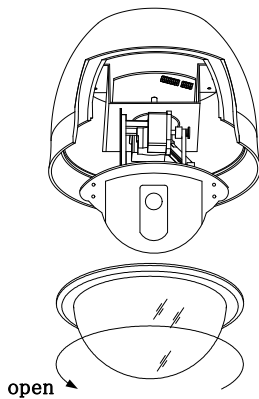

Figure 5

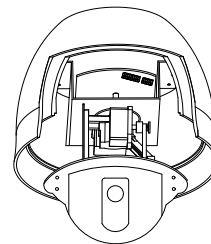

Figure 6

- b) Set the dome protocol, baud rate and address as per earlier instructions.
c) Refit the dome cover.

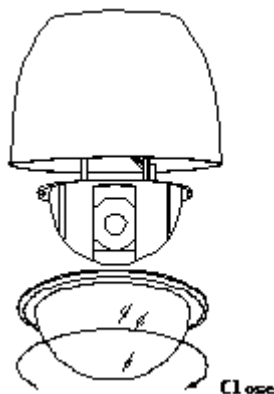

Figure 7

Installation of the bracket

- a) Make four M8 holes in the wall, and put the four M8 bolts into the holes as Figure 8.
- b) Make a hole at the center of the four holes to connect the cable of the bracket as Figure 8.
- c) Put the bracket on the wall and tight the four M8 screws as Figure 9.

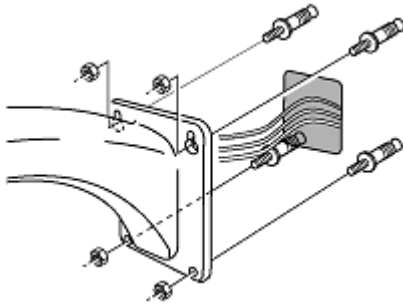

Figure 8

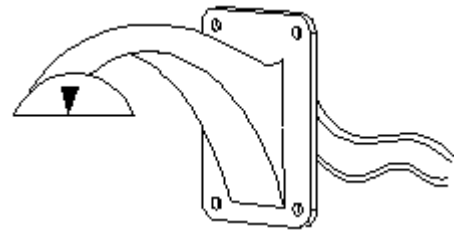

Figure 9

- d) Match the “▼” of the bracket (A) to the “▲” of the dome (B) as Figure 10.

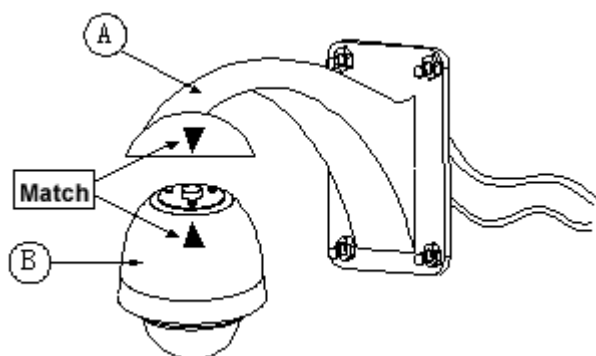

Figure 10

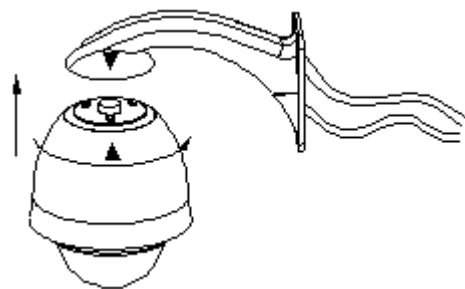

Figure 11

- e) Push the dome up and turn anti-clockwise as Figure 11.

f) Lock the housing as Figure 12.

g) Fit the dome retaining screws as Figure 13.

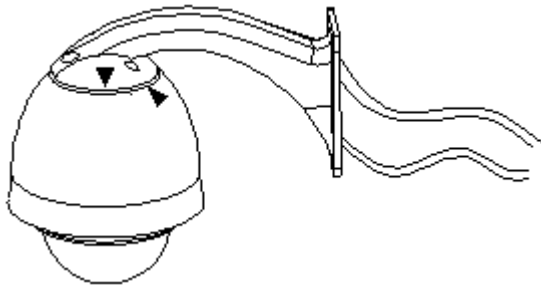

Figure 12

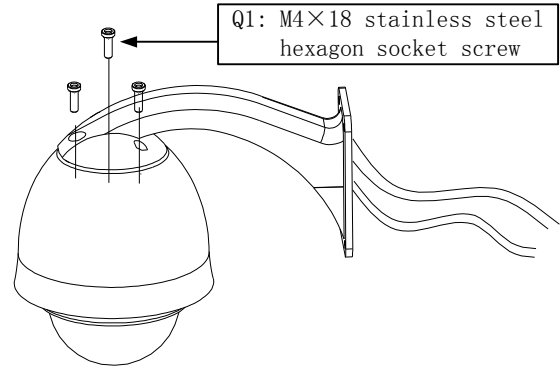

Figure 13

h) Connect the control cable as Figure 14

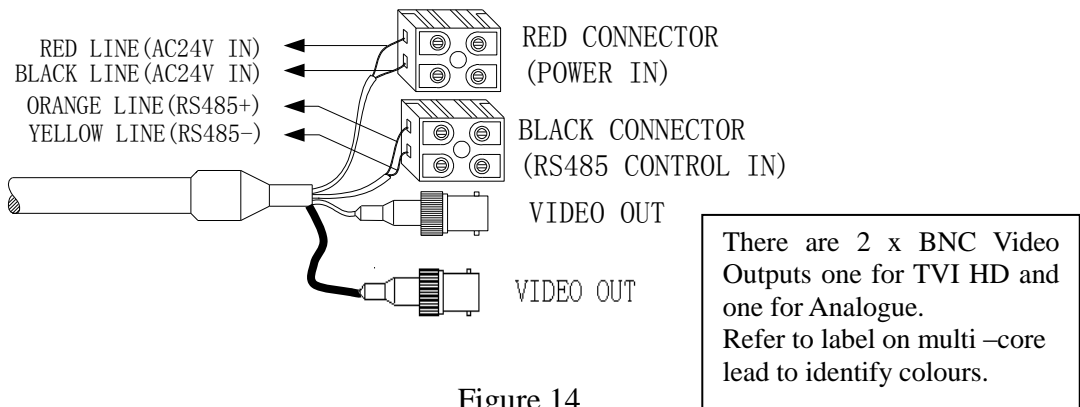

Figure 14

Indoor Ceiling Installation

- a) Install the pedestal on the base plate (as Figure 15).

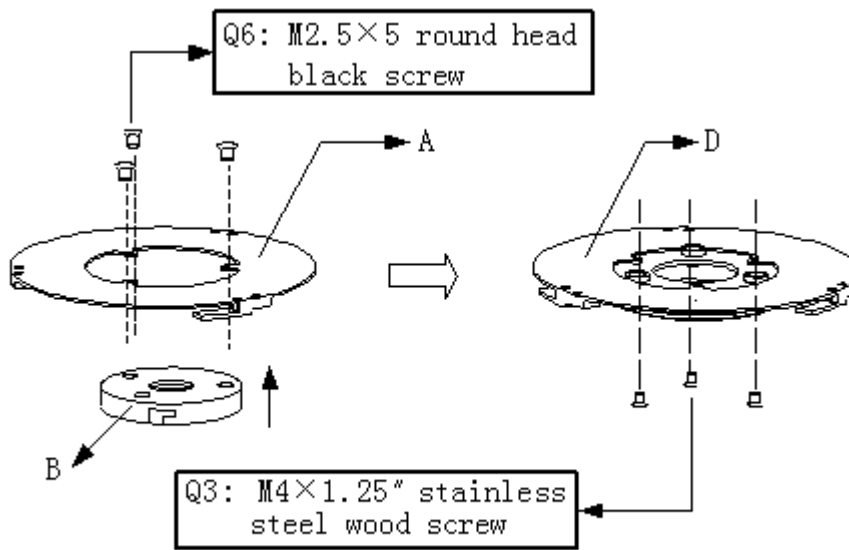

Figure 15

Figure 16

- c) Fix the pedestal assembly on the ceiling (Figure 16).
- d) Match the “MARK” on the ball with the notch on the pedestal, push the ball upward to the end and rotate clockwise until it clicks (as shown in Figure 17).
- e) Fit the decoration ceiling ring (C) by rotating it clockwise until it is tight (Figure 17).
- f) Figure 18 shows the unit installed.

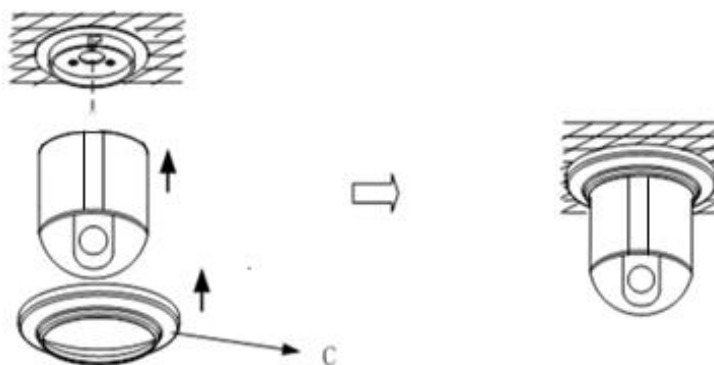

Figure 17

Figure 18

Indoor embedded installation

Note: To fit this dome into a ceiling, the thickness of the ceiling must be less than 1.65 inches (4.2 cm) but thicker than 0.38 inches (0.8cm). The ceiling must withstand 4 times the load of the dome weight.

- a) Cut out the ceiling template supplied as per figure 19 and mark the centre point of the dome position on the ceiling.

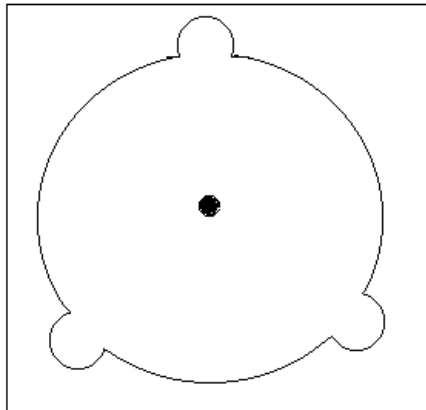

Figure 19

- b) Using the red spot to centre the template draw around the shape as per Figure 20.

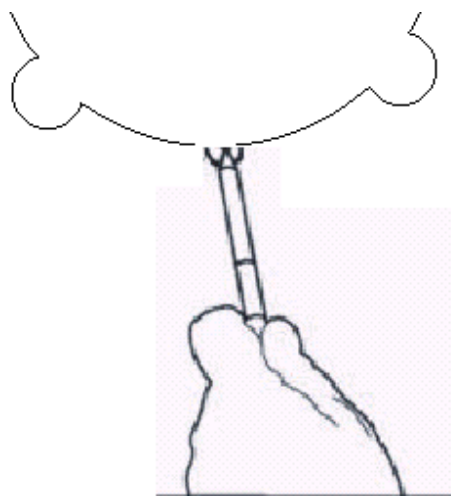

Figure 20

- c) Cut out the ceiling material using an appropriate cutting tool (Figure 21)

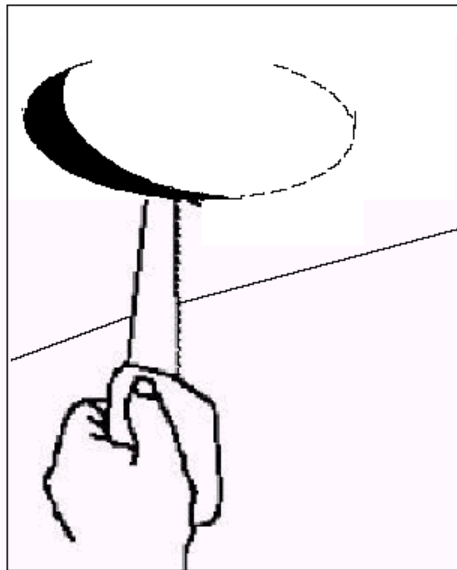

Figure 21

- d) Fit the “installation pedestal” with the embedded mount (Figure 22)

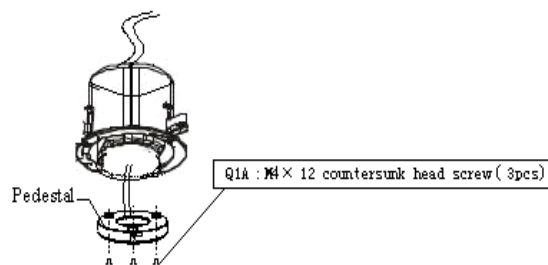

Figure 22

- e) For easy installation, adjust the three swing mounting clips so that the distance between the clips and the flange is a little longer than ceiling thickness.
- f) Now swing the three mounting clips flat against the body of the unit and locate the body into the ceiling void. The flange should fit flush to the ceiling.
- g) Now turn the three mounting clip bolts so that they press against the ceiling. The ceiling is now clamped between the mounting clips and the flange, leaving the unit body secured in the ceiling void.
- h) See Figure 23 below.

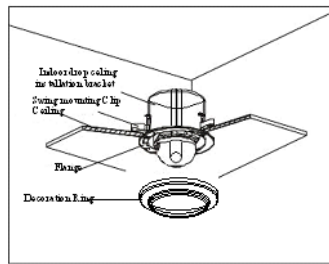

Figure 23

Alarm Input cable connections:

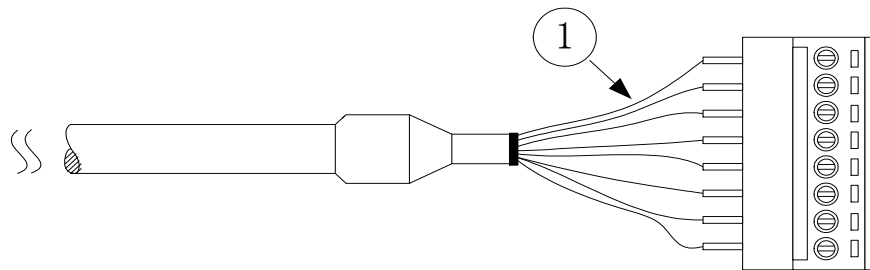

Figure 24

RED (Thin)	: ALARM-1 INPUT
ORANGE	: ALARM-2 INPUT
YELLOW	: ALARM-3 INPUT
BLUE	: ALARM OUT N/O
WHITE	: ALARM OUT COMMON
BLACK (Thin)	: ALARM IN COMMON
RED (Thick)	: 24v AC POWER
BLACK (Thick)	: 24V AC POWER COMMON
YELLOW	: RS485 -
ORANGE	: RS485 +

Figure 25

Note: The alarm input must be a zero volt switch. Any voltage signals will damage the dome. When multiple alarm signals are triggered the dome will respond to them, one by one, and the response time interval will be 2 seconds. When more than one alarm signal is received, the dome will not respond to “line scanning”, “tracking” and “self-learning” functions.

Connect the alarm lines as Figure 25

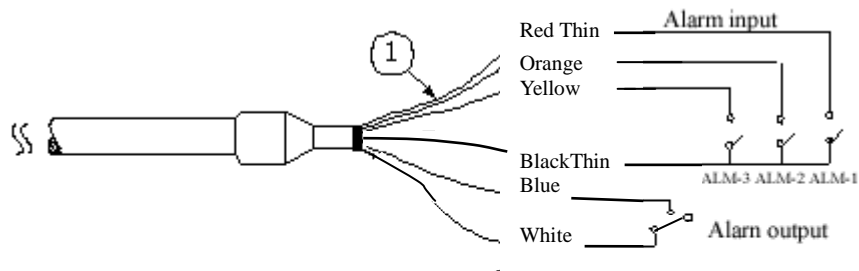

Figure 25

3 channel alarm input activation & single channel alarm output

One of the special features of this dome is that it has three in-built alarm channels to call three independent presets. This means that for example you may have a door contact and when the contact is closed, it sends a 0 volt alarm switch to the dome on one of the three alarm channels. The dome will then call a previously set preset position and lock the camera onto that position. A single channel alarm out, allows the connection of an audible alarm, lighting or other warning device. When more than one alarm input channel is utilised and activated, the dome will switch to the next channel after two seconds. However once an alarm input channel has been activated, the dome will remain locked to the preset position/s and will not resume a patrol, auto scan or a record pattern until the alarm condition is cleared. However the Alarm Setup options in the System Setup menu can be set to restart a tour if necessary.

NOTE: THE ALARM INPUT MUST BE VOLTAGE FREE OR YOU MAY DAMAGE THE DOME

Connecting the Input Alarm devices

You will need to decide how many alarm channels will be utilised. For each alarm channel you will need a pair of cable connections and it is recommended that a CAT5 twisted pair be utilised. Connect one core to the selected input alarm channel and the other to the ground (GND) connection. The ground is a common connection for all three alarm channels. At the alarm end connect to the alarm device. This must be a 0 volt switch and maybe for example a door switch. Check that the alarm device passes a voltage free switch as any other input signal may damage the dome.

Each of the three alarm channels call a different preset number when the 0v switch is detected by the dome. This allows the dome to move immediately to the selected preset position in an alarm condition. The following alarm channels call the preset range 1 ~ 50 when activated:

Alarm Channel No 1

Alarm Channel No 2

Alarm Channel No 3

To set these special presets, if you have set up alarm channel 1, move the dome camera to where you wish alarm 1 preset to move to, and using the keypad press the preset button followed by preset number. Then if you have set up alarm channel 2, move the dome camera to where you wish alarm 2 preset to move to, and using the keypad press the Preset button followed by the next preset number.

When more than one alarm channel is utilised and activated, the dome will respond to each alarm by calling the relevant preset and switching to the next preset after two seconds. The dome will lock on to the last alarm activated and will not resume a patrol, auto scan or record pattern until the alarm condition is cleared or the Alarm Setup options in the dome System Setup menu are set to restart a tour/patrol etc.

Example: Connecting Alarm 1 channel to a door contact

Here is an example scenario. A company requires a dome to run a patrol (tour) continuously viewing three preset points. One of the preset points is the main entrance door to the building. The requirement is to ensure that during out of hours the entrance door is not breached. The dome alarm 1 channel is connected to a door contact on the main entrance door. A CAT5 twisted pair is connected at the dome end to the RED Alarm 1 and the BLACK Ground connection on the dome alarm cable. At the door contact end the twisted pair is connected either way round. The dome is then set up for a tour using presets 01 to 04 and called TOUR 1. In addition preset 29 is set up focusing the dome camera at the door entrance. When the building is vacated the dome is left running a tour of the four presets. If the door contact is closed a voltage free switch is made on the Alarm 1 channel. The dome then automatically calls preset 29 which locks onto the main entrance door. In the System Setup menu select Alarm Setup, Alarm No., set PATROL 1 in Action menu and switch Alarm to ON. The dome will revert to PATROL/TOUR 1.

Connecting the Output Alarm

In addition to the alarm inputs, this dome will activate an alarm output if an alarm input is triggered. There are two connections for the alarm output, a common and a normally open connection. Again this is a 0 volt switch and could be used for example to close a circuit to an audible alarm, lighting or other warning devices. Ensure that the switch line does not carry any voltage. Again this switch remains activated until the input alarm/s has been cleared/reset.

Technical data table

Power Supply	24V AC 1.7A 50/60Hz
Power Consumption	Indoors without heater: 15W Outdoors with heater: 35W
Synchronisation	Internal / External
Preset positions	128
No. of Tours / Patrols	6
Pattern record time	200 seconds
Alarms	3 x Input Alarms 1 x Output Alarm
Privacy zone masking	6 zones (only applies to cameras with this functionality)
Zoom rotation interaction	The dome will automatically adjust manual control speed
Auto overturning	The camera rotates 180° when vertical position reached
Pan scanning	360° programmable
Pan speed	0° ~ 300° per second
Pan range	360° continuously
Tilt range	0° ~ 90°
Tilt speed	0° ~ 120° per second
Communication	RS485
Baud Rate	2400/4800/9600/19200
Fan / Heater	Auto (outdoor use only)
Relative humidity	10 ~ 75%
Working Temperature	Indoor: 0°C ~ +40°C Outdoor -35°C ~ +55°C

Appendix A: Lightning Proof and Surge Signal Proof

This product adopts TVS lightning proof technology to prevent damage by a lightning strike below 1500 W and surge impulse signals. However it is also necessary to ensure that the following precautions are taken to ensure electrical safety:

- Keep the communication cables at least 50 meters away from high voltage equipment or cables.
- Where possible locate outdoor cables under eaves to provide best protection.
- In an open area run cables in steel tubing and attach a single point ground to the tube.
- In areas prone to thunderstorms or high EMF (such as a high voltage transformer substation), additional lightning proof equipment must be installed.
- Always design the installation taking account of the building lightning proof requirements and grounding of outdoor equipment in accordance with the national and industrial standards.
- The system must be grounded with equal potentials. The earth ground connection must satisfy anti-interference and electrical safety requirements and must not short circuit the high voltage electricity network. When the system is grounded separately, the resistance of the down conductor should be $\leq 4 \Omega$ and the sectional size of the down conductor should be $\leq 25\text{mm}^2$ (refer to Fig 26).

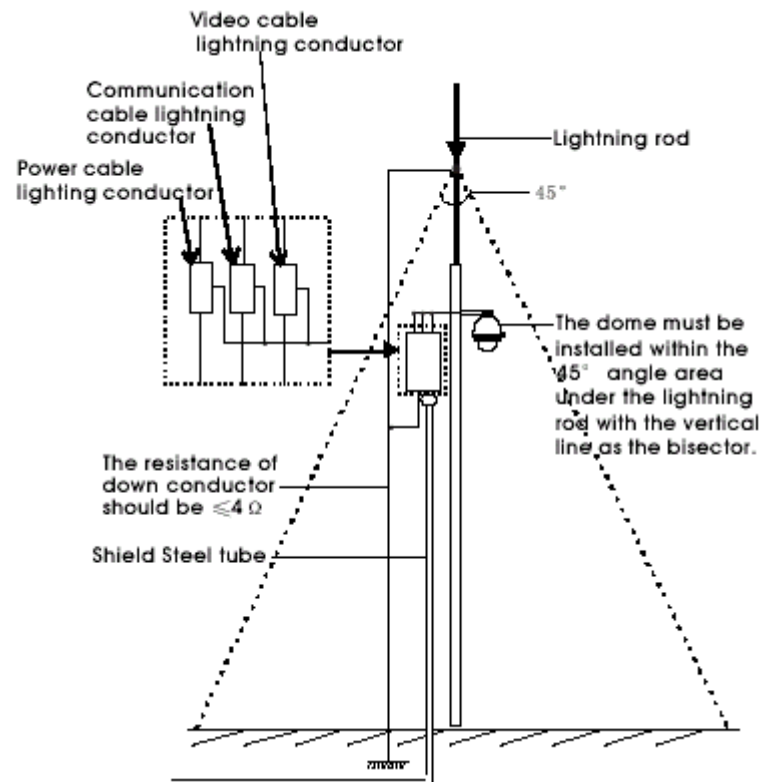

Figure 26

NOTE: This technology HELPS prevent the dome and camera from being damaged by lightning strikes but under no circumstances does it guarantee protection. Domes or cameras struck by lightning will not be covered by the warranty.

Appendix B: General Information

The Cleaning of Clear Dome Cover

To obtain constant clear images, the user should clean the dome cover periodically.

- Be very careful when cleaning. Hold the dome cover ring only to avoid touching the acrylic dome cover. The acid from fingerprints will corrode the coating and any scratches on the dome cover may cause distorted or poor images.
- Use a soft dry cloth or a similar to clean the inner and outer surfaces.
- For more stubborn contamination, use a neutral detergent. Any cleanser for high-grade furniture is applicable.

Troubleshooting

1. To avoid problems and to ensure the PTZ has been correctly setup it is always advisable to test the equipment in your workshop before you go on-site. If workshop setup is successful, any problems experienced on-site will be greatly minimized.

2. Always read these instructions before you connect the equipment to any power supply and check that you are using the correct rated power supply and voltage. Never connect non-regulated power supplies.

If you are having problems with no video, power the PTZ and plug the video cable direct into your monitor. If still no video then check if PTZ is running the initial self test. If not check power to the PTZ, cables and connections. Remember that every PTZ is tested before despatch to you so it will be very unlikely to be a faulty PTZ unit. Note that video loss can occur on a long cable run, or loss of signal strength resulting in no video, poor quality video or even video in black and white mode. Ensure the termination jumper is correctly set in the PTZ dome head. This is accurately detailed in this manual.

3. If video is okay but the telemetry is not working then check the dipswitch settings in the dome agree with the settings in the control unit i.e keypad or DVR. The dipswitches set the protocol, baud rate and PTZ address. Ensure that the RS485 cable connecting the PTZ to the control unit is connected the right way around.