





All-In-One HD-TVI Camera Code: [SEE835G](#)

The TVision range of CCTV cameras utilise HD-TVI technology to transmit full 1080p HD video signals over Co-ax cable.

HD-TVI offers many benefits and provides great value for money. 1080p TVI images are a staggering 20x the quality of basic CIF analogue. What's more the TVI signal has a high resistance to electro magnetic interference (EMI), allowing for cable runs of up to 500m without the need for amplifiers or repeaters.

There are also no complicated skills or techniques to learn as TVI installations use the same Co-ax cable and BNC connectors as analogue installs. As TVI still uses 75 ohm Co-ax cable it is easy to upgrade older systems without having to rewire.

HD-TVI is a great choice as it is fast becoming the global standard for HD CCTV. Unlike proprietary technologies such as HD-CVI which are only supported by a single manufacturer, HD-TVI is supported by many.

Introduction	2
Traditional HD-TVI Camera (Code: SEE250/250L)	4
IR Fixed External HD-TVI Mini Dome Cameras (Code: SEE515)	8
IR External HD-TVI Dome Camera (Code: SEE350W)	10
Fixed Internal HD-TVI Dome Camera (Code: SEE520W)	12
IR Varifocal Internal HD-TVI Dome (Code: SEE550W)	14
IR Fixed Lens HD-TVI Eyeball Cameras (Code: SEE800)	16
IR Varifocal HD-TVI Eyeball Cameras (Code: SEE810)	18
Motorised Zoom IR Varifocal HD-TVI Eyeball Camera (Code: SEE860)	20
External All-In-One IR Camera (Code: SEE835)	22
Covert HD-TVI Modules (Code: SEE905/915)	24
Covert HD-TVI Ceiling Camera (Code: SEE990S)	26
Accessing The OSD & Camera Adjustments	28
OSD Menu System	29
Getting The Most Out Of The TVision Range	32
Fault Finding	35
Other Products To Consider	37

SEE250/250L



SEE250 No Lens
SEE250L 2.8-12mm

Description

A traditional style of camera to offer a reassuring CCTV presence in any retail environment. This camera offers great flexibility as the lens is not pre-fitted and can be changed to suit the installation. Available with a popular 2.8-12mm lens option or you can choose from our wide range of lenses up to 50mm for great potential to zoom in on a gate or doorway.

Features

- HD & Analogue Outputs
- 2.8-12mm Lens Option
- Hi-Def Colour 1080p
- True Day/Night
- CS Mount Design
- Wide Dynamic Range
- 8x Digital Zoom
- 16 Zone Privacy Masking
- Motion Detection
- Mirror Function

Specification

Lens	2.8-12mm Varifocal Lens (SEE250L)
Resolution	1920 x 1080P
Video Outputs	HD & Analogue
Day/Night	True Day/Night Mechanical IR Cut Filter
Minimum Illumination	0.01 Lux
OSD Control	Rear Buttons & Up The Co-ax Control
WDR	True WDR
Digital Zoom	8x
Power/Consumption	12V DC, 150mA
Build	Metal Case
Dimensions	115 x 65 x 80mm

Connecting The Camera

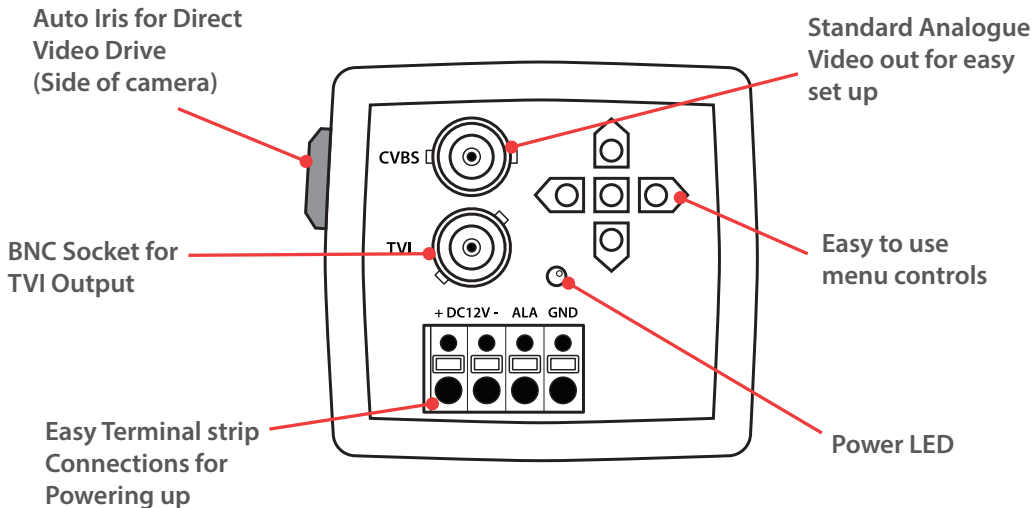

Auto-Iris Direct Drive Connections

Auto Iris type lenses require the 4-pin connector to be attached to the camera. In most instances your lens will be pre-wired with this plug, but if needed on-line [Tip 322](#) which includes a full wiring diagram can be found at www.tvision.technology.

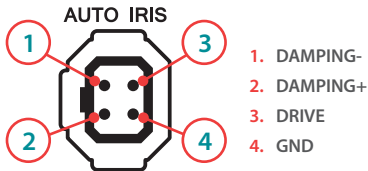
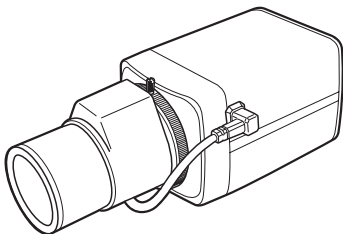

C Or CS Mount Lenses

Most lenses are available in 2 different mounting options - C mount and CS mount.

CS mount lenses are now the most popular size as they are shorter and more compact than C mount lenses. Most cameras are now manufactured to accept CS mount lenses. Before fitting the lens you need to verify that you are using a CS mount lens with the camera. You can confirm this with your lens supplier or the literature that came with your lens, check the instructions or packaging to see if your lens is a C or a CS mount version.

If your lens is a C mount type you can still fit it to the camera using a C to CS adapter. See the on-line [Tip 323](#) at www.tvision.technology.

Using A CS Mount Lens

If you are using a standard CS mount lens you can screw the lens straight into the camera without the need for C-CS adapter ring.

Note

To produce a true HD image TVI cameras require a Mega Pixel lens. Standard lenses are not produced to a high enough quality.

Adjusting The Back Focus

Once you have fitted the lens and have an image on the monitor, you may find that you can not properly focus the picture using the fine focal adjustment on the lens itself. In this case you would need to manually adjust the back focusing on the camera. Adjusting the back focusing moves the CCD slightly closer to or further away from the lens.

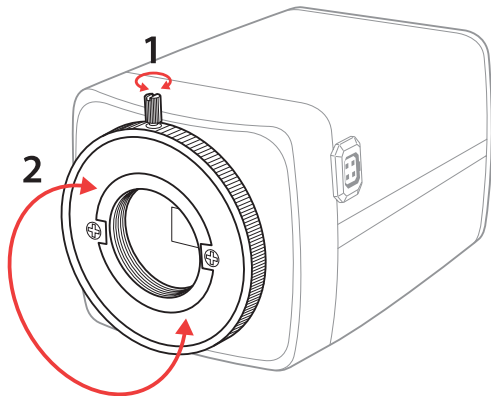

To adjust the back focusing you will first need to loosen the cross-head locking screw on the back focusing ring. This will release the ring allowing it to rotate as shown. Rotating the back focusing ring moves the CCD forwards and backwards.

This is a trial and error process. Slowly rotate the ring clockwise or anti-clockwise whilst watching for improvements to the image. Once satisfied it is important to re-tighten the locking screw to prevent the back focusing ring from being adjusted by accident.

Note

If it appears that the lens will never focus correctly then it is possible that you are trying to fit a **C-mount** lens on the camera, not a **CS-mount** lens. If this is the case you will have to use a **CCT297** adapter ring as shown below.

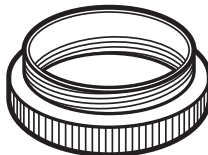

CCT297 - C-mount to CS-mount adapter ring

SEE515B & SEE515W



Description

Specifically designed for retail and commercial use, it's small enough to be discreet yet big enough to be a subtle deterrent.

A mechanical IR filter gives accurate colour reproduction during daylight or in brightly lit environments such as shops whilst the built-in IR LEDs offer extra illumination when darkness or ambient light levels fall.

Features

- HD & Analogue Outputs
- Wide Angle 3.6mm Lens
- Hi-Def Colour 1080p
- True Day/Night
- IP66 Rated Metal Case
- 12x IR With 15m Range
- 16x Digital Zoom
- Privacy Masking
- Motion Detection
- Mirror Function

Specification

Lens	2.1 Mega Pixel 3.6mm Fixed Lens
Resolution	1920 x 1080P
Video Outputs	HD & Analogue
Day/Night	True Day/Night Mechanical IR Cut Filter
IR LEDs	12
IR Range	15m
OSD Control	In-line Joystick & Up The Co-ax Control
WDR	True WDR
Power/Consumption	12V DC, 260mA (IR On)
Build	IP66 Rated Metal Case
Dimensions	Ø95mm x 60mm (H)

Connecting The Camera

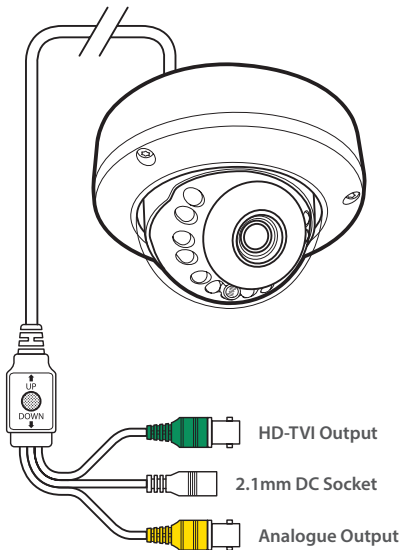

Mounting The Camera

When mounting the SEE515 you will first need to remove the upper housing. Remove the three Torx screws to release it from the base of the camera. To secure the camera screw through the three holes in the base and into the mounting surface.

Once securely mounted the upper housing can be screwed back on to the camera base.

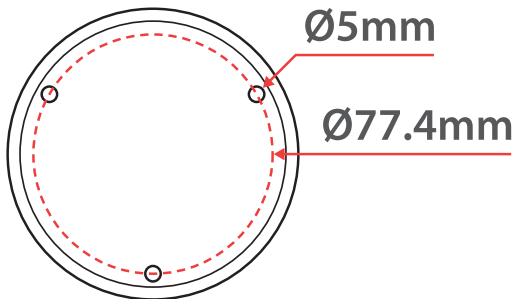

SEE350W



Description

The SEE350W captures stunning images any time of day thanks to its True Day/Night capabilities and 30m IR range.

This external IR dome is fitted with a 2.8-12mm Varifocal 2.1 Mega Pixel Lens and features 30x IR LEDs, Wide Dynamic Range, 3D Digital Noise Reduction and a True Day-Night Mechanical IR filter for clear night time viewing.

Features

- HD & Analogue Outputs
- 2.8-12mm Lens
- Hi-Def Colour 1080p
- True Day/Night
- 30x IR With 30m Range
- Wide Dynamic Range
- 8x Digital Zoom
- 16 Zone Privacy Masking
- Motion Detection
- Mirror Function

Specification

Lens	2.1 Mega Pixel 2.8-12mm Varifocal Lens
Resolution	1920 x 1080P
Video Outputs	HD & Analogue
Day/Night	True Day/Night Mechanical IR Cut Filter
IR LEDs	30
IR Range	30m
OSD Control	In-line Joystick & Up The Co-ax Control
WDR	True WDR
Power/Consumption	12V DC, 330mA (IR On)
Build	IP66 Rated Metal Case
Dimensions	Ø150mm x 128mm (H)

Connecting The Camera

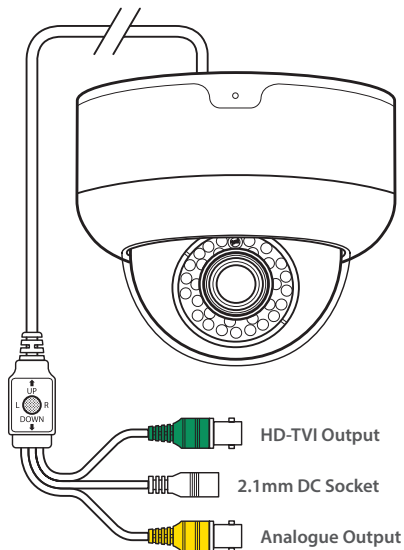

Mounting The Camera

To mount the camera you will first need to remove the mounting plate. To do this loosen the hex screw at the front of the plate, slide the plate back and lift off. Secure the fixing plate to the mounting surface by screwing through the three holes.

Once the plate has been fixed to the mounting surface the camera can be re-attached to the mounting plate.

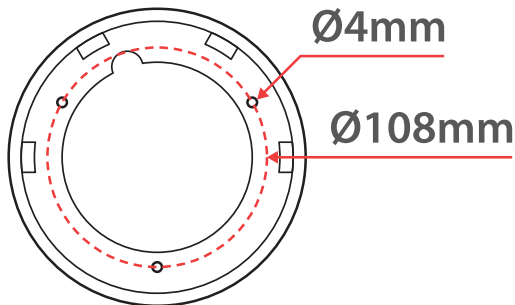

SEE520W



Description

This internal dome is feature packed and great value for indoor use.

The dual output of HD-TVI and analogue allows a high definition image to be recorded on to the DVR whilst a local feed can be sent to a basic monitor on a shop counter or reception desk.

Features

- HD & Analogue Outputs
- Wide Angle 3.6mm Lens
- Hi-Def Colour 1080p
- True Day/Night
- 0.01 Lux
- Wide Dynamic Range
- 8x Digital Zoom
- 16 Zone Privacy Masking
- Motion Detection
- Mirror Function

Specification

Lens	2.1 Mega Pixel 3.6mm Fixed Lens
Resolution	1920 x 1080P
Video Outputs	HD & Analogue
Day/Night	True Day/Night Mechanical IR Cut Filter
Minimum Illumination	0.01 Lux
OSD Control	In-line Joystick & Up The Co-ax Control
WDR	True WDR
Digital Zoom	8x
Power/Consumption	12V DC, 110mA
Build	Plastic Case
Dimensions	Ø100mm x 70mm (H)

Connecting The Camera

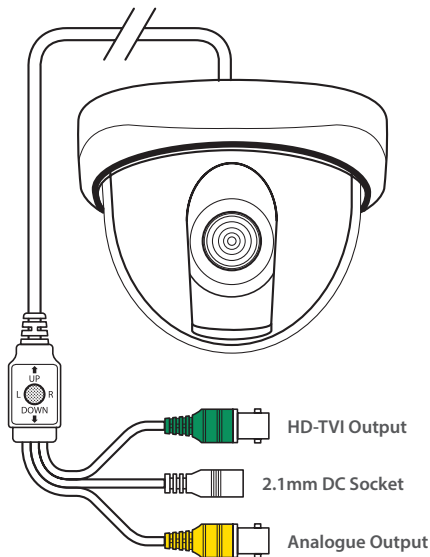

Mounting The Camera

When mounting the SEE520W you will first need to remove the upper housing. Hold the base of the camera, twist the clear dome counter clockwise, remove, and lift out the black inner dome. To secure the camera screw through the two larger holes in the base and into the mounting surface.

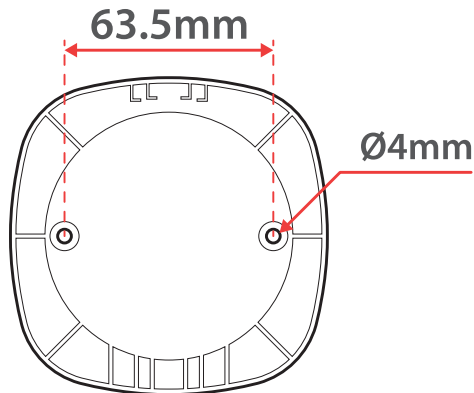

SEE550W



Description

An attractive dome to suit indoor use in offices or retail outlets.

The dome's built-in IR LED array, motion detection and digital zoom features make it a great choice for installation where the lighting levels are set to a minimum at night. This allows the user to get the best out of their surveillance system even during closing hours.

Features

- HD & Analogue Outputs
- 2.8-12mm Lens
- Hi-Def Colour 1080p
- True Day/Night
- 22x IR With 15m Range
- Wide Dynamic Range
- 8x Digital Zoom
- 16 Zone Privacy Masking
- Motion Detection
- Mirror Function

Specification

Lens	2.1 Mega Pixel 2.8-12mm Varifocal Lens
Resolution	1920 x 1080P
Video Outputs	HD & Analogue
Day/Night	True Day/Night Mechanical IR Cut Filter
IR LEDs	22
IR Range	15m
OSD Control	In-line Joystick & Up The Co-ax Control
WDR	True WDR
Power/Consumption	12V DC, 350mA (IR On)
Build	Plastic Case
Dimensions	Ø130mm x 95mm (H)

Connecting The Camera

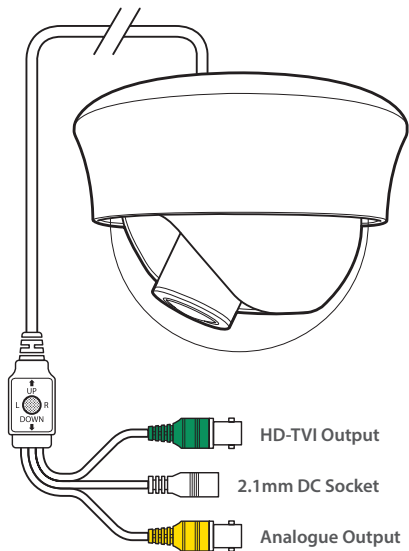

Mounting The Camera

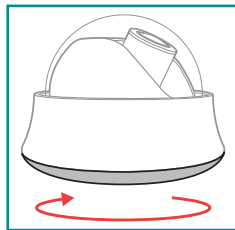

1. Rotate the bottom part of the case and remove.

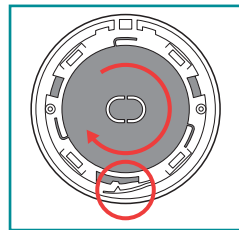

2. Pull down the locking clip and rotate the mounting plate to release.

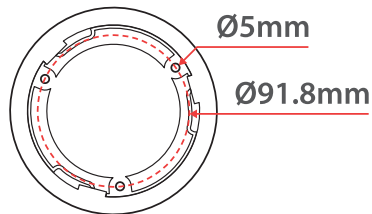

SEE800W & SEE800G



Description

Our popular Eyeball cameras are now in HD! (1080P TVI) The mini 3.6mm fixed models come in both polar white and graphite grey.

We know it is a firm favourite with installers it's easy to see why as it looks just as good indoors as out.

Features

- HD & Analogue Outputs
- Wide Angle 3.6mm Lens
- Hi-Def Colour 1080p
- True Day/Night
- IP66 Rated Metal Case
- 24x IR With 15m Range
- 8x Digital Zoom
- 16 Zone Privacy Masking
- Motion Detection
- Mirror Function

Specification

Lens	2.1 Mega Pixel 3.6mm Fixed Lens
Resolution	1920 x 1080P
Video Outputs	HD & Analogue
Day/Night	True Day/Night Mechanical IR Cut Filter
IR LEDs	24
IR Range	15m
OSD Control	In-line Joystick & Up The Co-ax Control
WDR	True WDR
Power/Consumption	12V DC, 330mA (IR On)
Build	IP66 Rated Metal Case
Dimensions	Ø93mm x 68mm (H)

Connecting The Camera

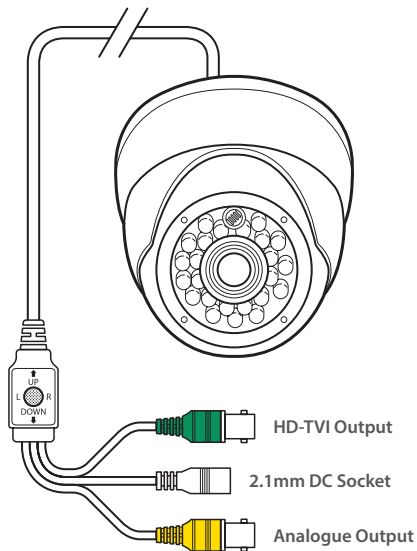

Mounting The Camera

To mount the camera you will first need to remove the fixing plate from the base of the camera and attach it to the mounting surface. To remove the fixing plate simply twist to unscrew.

Once securely mounted the camera can be screwed back on to the fixing plate.

A fixing hole guide is shown below.

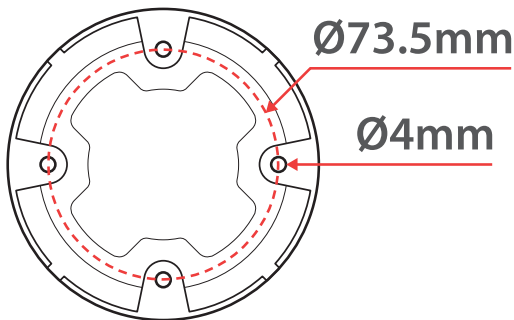

SEE810G & SEE810W



Description

A great all-rounder, this varifocal eyeball design CCTV camera will suit 90% of your surveillance requirements. It has a mechanical IR filter to allow maximum performance of its 30 on board IR LEDs at night and filters out unwanted IR light during the day.

An extra deep base is available for easy cabling to the camera and the flexible eyeball design allows for wall or ceiling mounting.

Features

- HD & Analogue Outputs
- 2.8-12mm Lens
- Hi-Def Colour 1080p
- True Day/Night
- IP66 Rated Metal Case
- 36x IR With 25m Range
- 8x Digital Zoom
- 16 Zone Privacy Masking
- Motion Detection
- Mirror Function

Specification

Lens	2.1 Mega Pixel 2.8-12mm Varifocal Lens
Resolution	1920 x 1080P
Video Outputs	HD & Analogue
Day/Night	True Day/Night Mechanical IR Cut Filter
IR LEDs	36
IR Range	25m
OSD Control	In-line Joystick & Up The Co-ax Control
WDR	True WDR
Power/Consumption	12V DC, 350mA (IR On)
Build	IP66 Rated Metal Case
Dimensions	Ø118mm x 80mm (H)

Connecting The Camera

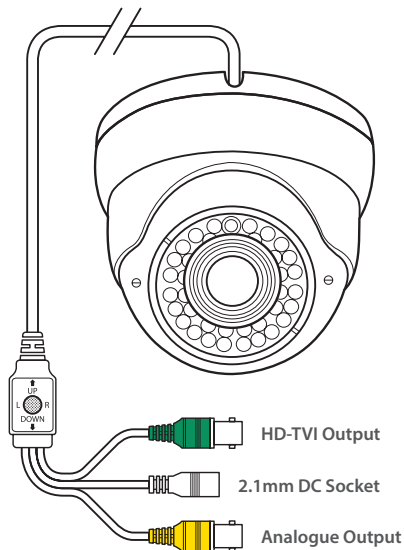

Mounting The Camera

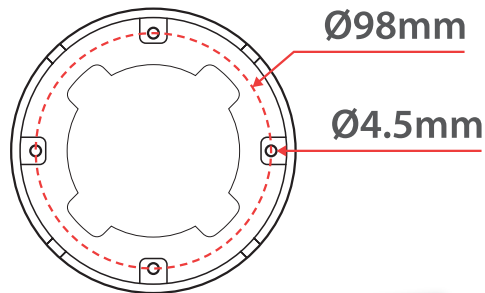

Easy Cabling!

Extra Deep Bases



We also offer extra deep bases which attach to the fixing plate and provide more room to make cabling even easier. The deep bases are available in Grey (SEE811G) and White (SEE811W) to match the cameras.

SEE860G



Description

All the same great features of the SEE810 with the added benefit of motorised zoom and focus. This offers great flexibility as it lets you adjust the camera at a later date from the DVR so no need for climbing ladders.

You can manually focus from the DVR too or just let the helpful autofocus do the work for you.

Features

- HD & Analogue Outputs
- 2.8-12mm Lens
- Hi-Def Colour 1080p
- True Day/Night
- IP66 Rated Metal Case
- 36x IR With 25m Range
- Motorised Zoom & Focus
- 16 Zone Privacy Masking
- Motion Detection
- Mirror Function

Specification

Lens	2.1 Mega Pixel 2.8-12mm Varifocal Lens
Resolution	1920 x 1080P
Video Outputs	HD & Analogue
Day/Night	True Day/Night Mechanical IR Cut Filter
IR LEDs	36
IR Range	25m
OSD Control	In-line Joystick & Up The Co-ax Control
WDR	True WDR
Power/Consumption	12V DC, 500mA (IR On & Zooming)
Build	IP66 Rated Metal Case
Dimensions	Ø118mm x 80mm (H)

Connecting The Camera

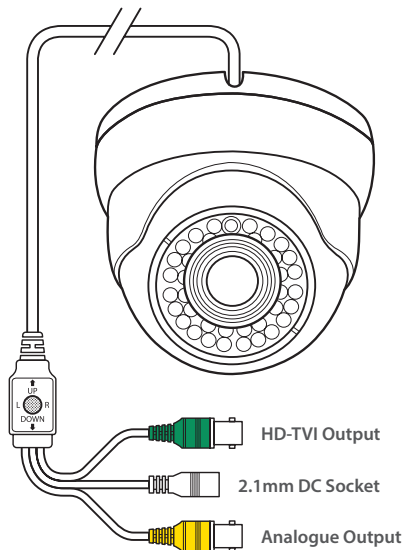

Mounting The Camera

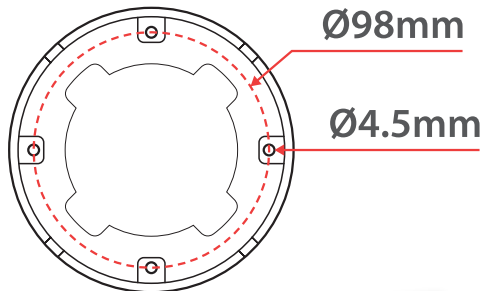

Easy Cabling!

Extra Deep Base



We also offer an extra deep base which attaches to the fixing plate and provides more room to make cabling even easier. The deep bases are available in Grey (SEE811G) to match the camera exactly.

SEE835G & SEE835W



Description

A tough but attractive camera, great for industrial and outdoor commercial use. A cable managed bracket and extra deep base make this an installer's dream to fit. Up the co-ax control will even allow remote set up so you won't need to do it up the ladder. Not only does the camera have a high powered IR range of 35 metres, it also features motion detection, privacy masking, mirror and digital zoom functions.

Features

- HD & Analogue Outputs
- 2.8-12mm Lens
- Hi-Def Colour 1080p
- True Day/Night
- Cable Managed Bracket
- 42x IR With 35m Range
- 8x Digital Zoom
- 16 Zone Privacy Masking
- Motion Detection
- Mirror Function

Specification

Lens	2.1 Mega Pixel 2.8-12mm Varifocal Lens
Resolution	1920 x 1080P
Video Outputs	HD & Analogue
Day/Night	True Day/Night Mechanical IR Cut Filter
IR LEDs	42
IR Range	35m
OSD Control	In-line Joystick & Up The Co-ax Control
WDR	True WDR
Power/Consumption	12V DC, 350mA (IR On)
Build	IP66 Rated Metal Case
Dimensions	308 x 85 x 85mm

Connecting The Camera

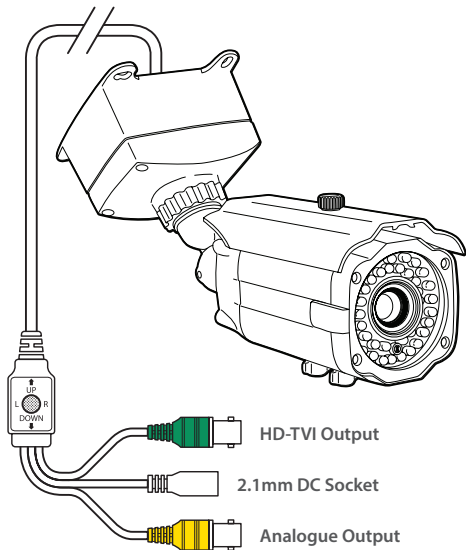

Mounting The Camera

There are four lugs on the base of the SEE835 used for mounting the camera.

The two top lugs have keyhole type fixing holes. By securing these two first you can then mark the positions of the bottom two holes. The camera can then be lifted off enabling you to drill the bottom two holes.

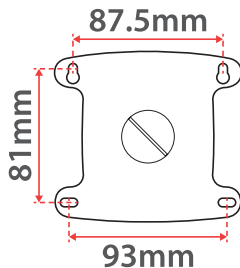

Manually Adjusting The Zoom & Focus

There are two knobs on the underside of the camera for adjusting the zoom and focus. The knob towards the front of the camera adjusts the focus. The knob furthest from the front is used for controlling manual zoom.

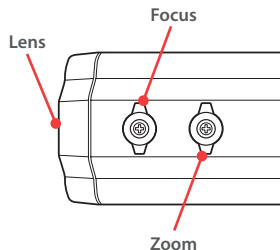

SEE905 & SEE915

SEE905

3.6mm Board Lens



SEE915

3.7mm Pinhole Lens

Description

When you are looking for a covert camera, it pays to go HD! The chances are you are trying to capture criminal activity red-handed on video so getting a great picture of the perpetrator is essential.

The SEE905 & SEE915 covert modules offer a great alternative to the ready made smoke or PIR case style as they can be hidden almost anywhere to suit the environment.

Features

- HD & Analogue Outputs
- Mini Size 30x30mm
- Hi-Def Colour 1080p
- Free Fixing Bracket
- Choice of Lenses
- Wide Dynamic Range
- 8x Digital Zoom
- 16 Zone Privacy Masking
- Motion Detection
- Mirror Function

Specification

Lens	2.1 Mega Pixel Fixed Lens
Resolution	1920 x 1080P
Video Outputs	HD & Analogue
Minimum Illumination	0.01 Lux
OSD Control	Up The Co-ax Control
WDR	True WDR
Power/Consumption	12V DC, 110mA
Bracket	Supplied
Build	Metal Case
Dimensions SEE905	30 x 30 x 29mm
Dimensions SEE915	30 x 30 x 20mm

Connecting The Camera

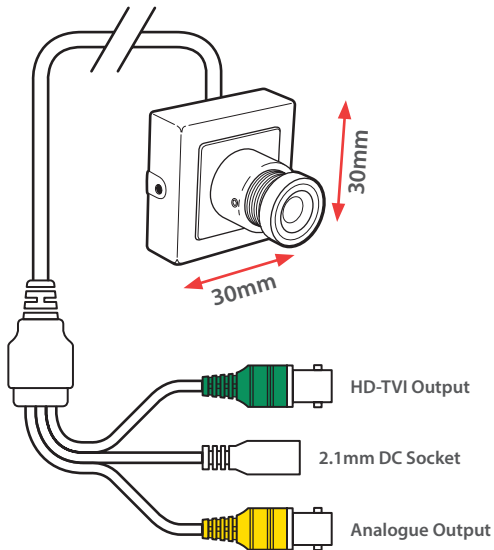

Mounting The Camera

The SEE905/915 is supplied with a free mounting bracket that can be easily fixed to virtually any surface.

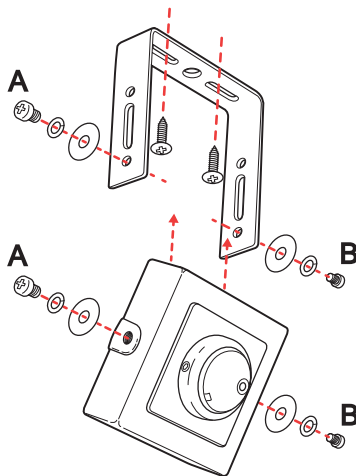

SEE990S



Description

This futuristic mini dome is a great choice for retail use. The flush mount case allows for easy installation into ceiling tiles for an understated CCTV presence in any high-end shopping outlet. A wide angle 3.6m lens gives general surveillance of most areas whilst built-in privacy masking allows you to block out any unwanted areas such as approaches to changing room areas.

Features

- HD & Analogue Outputs
- 3.6mm Pinhole Lens
- Hi-Def Colour 1080p
- 2.1 Mega Pixel Lens
- Flush mount
- Great For Retail
- 8x Digital Zoom
- 8 Zone Privacy Masking
- Motion Detection
- Mirror Function

Specification

Lens	2.1 Mega Pixel Fixed 3.6mm Pinhole Lens
Resolution	1920 x 1080P
Video Outputs	HD & Analogue
Minimum Illumination	0.01 Lux
OSD Control	Up The Co-ax Control
Digital Zoom	8x
Privacy Masking	8 Zone
Power/Consumption	12V DC, 110mA
Build	Metal Case
Dimensions	Ø85mm x 80mm (H)

Connecting The Camera

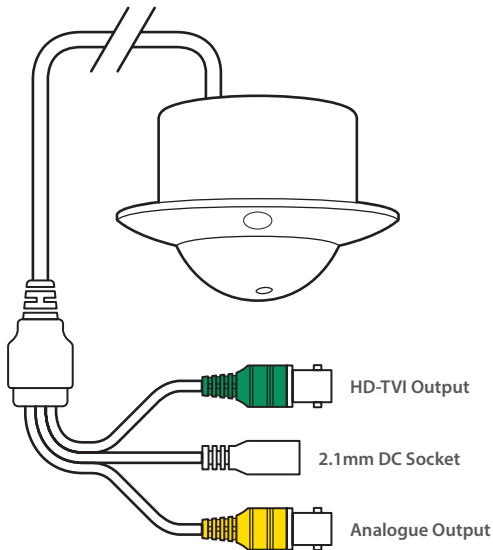

Mounting The Camera

The SEE990S was designed to be installed in suspended ceilings like those commonly found in offices and retail environments.

To mount the camera you will need to create a $\text{Ø}60\text{mm}$ hole in the mounting surface. To secure the camera, screw through the three fixing holes and into the ceiling.

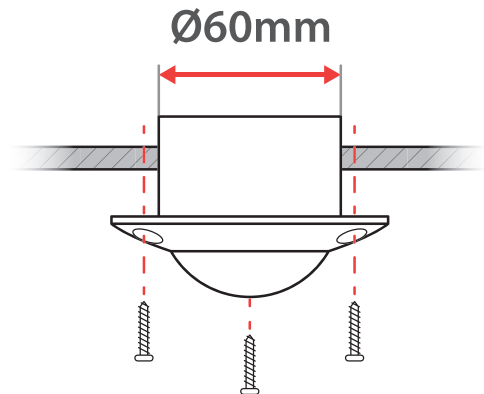

There are two ways in which to enter the camera's OSD menu as explained below:

In-line Joystick & Menu Buttons

A lot of the cameras in the TVision range have either an in-line joystick or menu control buttons on the camera itself.

The menu is displayed by pressing the joystick in or by pressing the centre button on the camera. Navigate through the menus and change parameters using the joystick or by pressing the direction buttons. To confirm your selection either press the joystick in or press the centre button.



Up The Co-ax Control

Every camera in the TVision range features up the Co-ax telemetry. This allows you to configure the camera by sending signals down the video Co-ax cable from the DVR. This method has the huge benefit of being able to setup the camera whilst next to the DVR. This eliminates the time consuming

process of climbing up and down ladders setting up cameras one at a time. It also enables you to instantly see on-screen the effects of any changes made.

This feature is only supported by newer DVRs such the AlienDVR TVI range.

To access the OSD menu via a DVR you will first need to view the camera you wish to configure. You then need to display the PTZ controls and press the "Iris +" button to enter the OSD menu. The direction buttons are then used for navigation and changing parameters. To confirm selections use the "Iris +" button. You can also adjust the **Zoom** and **Focus** on motorised zoom cameras using the zoom and focus buttons.

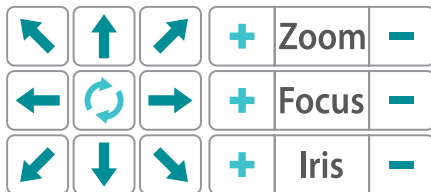

MENU ITEM	FEATURE	
FOCUS ADJ	ON / OFF	
2-MOTOR (MOTORISED ZOOM CAMERAS ONLY)	AF MODE:	AUTO / MANUAL
	SCANNING:	HALF / FULL
	ONEPUSHAF:	ON (PRESS 'OK' TO FOCUS)
	SYNC TDN:	ON / OFF
	INITIAL:	ON (PRESS TO RESET ZOOM)
LENS	ELC / ALC	
	ELC:	MODE: NORMAL / DEBLUR
	ALC:	MODE: INDOOR / OUTDOOR / DEBLUR
EXPOSURE	BRIGHTNESS:	0 ~ 20 (10)
	SHUTTER:	AUTO / MANUAL / FLICKER
	MANUAL:	SPEED: 1/25 ~ 1/16000 (1/25)
	SENS-UP:	X2 ~ X8 / OFF (X2)
	AGC:	0 ~ 20 (16)
BACKLIGHT	OFF / HLC / BLC / WDR	
	HLC:	LEVEL: 0 ~ 20 (10) MODE: ALL DAY / NIGHT ONLY
	BLC:	H POS: 0 ~ 20 (6) H-SIZE: 0 ~ 20 (5) V POS: 0 ~ 20 (4) V-SIZE: 0 ~ 20 (3)
	WDR:	WEIGHT: LOW / MIDDLE / HIGH
DAY&NIGHT	MODE: EXTERN / AUTO / COLOR / B&W	

Default settings are highlighted in **turquoise**.

Continued on the next page ▼

MENU ITEM	FEATURE
DAY&NIGHT (CONTINUED)	ANTI-SAT: 0 ~ 20 (7)
	EXTERN S/W: LOW / HIGH
	AGC THRES: 0 ~ 20 (11)
	AGC MARGIN: 0 ~ 20 (8)
	DELAY: LOW / MIDDLE / HIGH
WHITE BAL	AUTO / AUTOext / PRESET / MANUAL
	PRESET: PUSHING
	MANUAL: KELVIN: LOW / MIDDLE / HIGH B-GAIN: 0 ~ 20 (10) R-GAIN: 0 ~ 20 (10)
DNR	OFF / LOW / MIDDLE / HIGH
IMAGE	SHARPNESS: 0 ~ 10 (5)
	GAMMA: 0.45 ~ 0.65 (0.55)
	COLOR GAIN: 0 ~ 20 (12)
	MIRROR: OFF / ON
	FLIP: OFF / ON
	D-ZOOM: 1.0X ~ 8.0X (1.0X)
	ACE: OFF / LOW / MIDDLE / HIGH
	DEFOG: OFF / ON
	ON: MODE: AUTO / MANUAL LEVEL: LOW / MIDDLE / HIGH
	SHADING: OFF / ON
ON: WEIGHT: 0 ~ 100% (100%)	

MENU ITEM	FEATURE	
IMAGE (CONTINUED)	PRIVACY: OFF / ON ON: ZONE NUM: 0 ~ 15 (0) ZONE DISP: ON / OFF H-POS: 0 ~ 60 V-POS: 0 ~ 40 H-SIZE: 0 ~ 40	V-SIZE: 0 ~ 40 Y LEVEL: 0 ~ 20 (10) CR LEVEL: 0 ~ 20 (10) CB LEVEL: 0 ~ 20 (10)
MOTION	OFF / ON ON: SENSITIVITY: 0 ~ 20 (0) WINDOW: 0 ~ 6 (6) DET H-POS: 0 ~ 60 (0) DET V-POS: 0 ~ 40 (0)	DET H-SIZE: 0 ~ 60 (60) DET V-SIZE: 0 ~ 40 (34) MOTION OSD: OFF / ON ALARM: OFF / ON
SYSTEM	COM: CAM ID: 0 ~ 255 (1)	BAUDRATE: 2400 ~ 115200 (115200)
	IMAGE RANGE: USER / FULL / COMP	
	USER: OFFSET: 0 ~ 20 (8)	
	OUTPUT MODE: 1080P / 720P / 720P CROP	
	MONITOR: 0 / 1 / 2 / 3	
	FRAME RATE: 25 FPS / 30 FPS	
	CVBS: PAL / NTSC	
	LANGUAGE: ENG / CHN / CHN(S) / KOR / JPN / DEU / FRA / NLD / ESP / ITA	
COLOR BAR: OFF / ON		
RESET: PUSH TO RESET CAMERA BACK TO FACTORY DEFAULTS		

Default settings are highlighted in turquoise.

The TVision range has a comprehensive menu system that allows you to set up the camera to get the most out of it in different demanding situations, below is a guide to some of the key functions:

Exposure

In the exposure settings you are able to adjust the shutter speed and sensitivity of the CCD to control how much light is collected by the camera. This allows you to configure the camera to achieve the best image possible based on the environment in which it is situated.

Shutter

Controls how long the CCD is exposed to light. A slow shutter (opened for longer periods of time) makes the image brighter but any movement may appear blurred.

The shutter speed can be set to auto so that it automatically adjusts to changes in light levels producing bright images all the time. You can also manually set the shutter speed so that it is tailored to the environment in which it is installed.

Sens-Up

Sens-up technology makes the camera more sensitive to light giving better quality images in low light situations. You can set by how much the camera's sensitivity to light is intensified.

AGC (Automatic Gain Control)

AGC automatically adjusts the Video amplitude under various lighting conditions to maintain a bright image. You can choose the level of amplitude however setting it too high could produce a noisy image in low light conditions.

Backlight

The cameras feature three different backlight modes, HLC (Highlight Compensation), BLC (Backlight Compensation) and WDR (Wide Dynamic Range). All 3 modes are included on all camera models featured in this book. Each mode is designed to correct the brightness of the image in different environments as described below:

HLC

Masks areas of intense light to properly expose other areas of the image. For example a car's headlights would be masked reducing glare making the number plate visible.

When HLC is enabled the camera will automatically mask bright areas of the camera's image. Additionally you can choose between All Day or Night Only modes.

BLC

Adjusts the exposure of the entire image to properly expose a subject in the foreground when a bright light source, such as a window, is situated behind it.

When selected you then set the general area of the camera's image you wish to mask.

WDR

Digitally adjusts the exposure in different parts of the image to maintain optimum levels in both the dark and the bright areas.

The strength (Weight) of the WDR filter can be set to Low, Middle or High depending on the difference between the bright and dark areas of the image.

Day & Night

In the Day & Night settings you can control if or when the camera switches between a colour and a black & white image.

The gain Threshold and Margin can be set telling the camera to increase or decrease the video amplitude when switching from day to night and night to day.

A delay can also be set which will instruct the camera to wait for a set length of time before switching. This accommodates for any temporary drops in light.

Extern (External)

The switch between colour and black & white is controlled by an external trigger such as a photocell.

Auto

Auto is the most commonly used option. The camera will automatically switch to a black & white image when it detects light levels have dropped below a usable level.

Colour

The camera is forced to permanently produce a colour image. This is great in environments where there is constant light but could result in poor quality images in low light situations. As long as the camera is in colour mode the IR LEDs will not turn on.

B & W (Black & White)

The camera will permanently produce a black & white image. This is only recommended in areas where the light levels are always extremely low.

White Balance

White balance is configured so that objects appear a natural colour. There are various ways this can be achieved as explained below.

Auto

The white balance is continuously adjusted according to the colour temperature of the image.

Autoext

Makes allowances for natural light sources and adjusts the image's colour accordingly.

Preset

Automatically sets the white balance by holding a white object such as a piece of paper or card in-front of the camera and pressing set.

Manual

Allows you to manually fine tune the white balance of the image.

DNR (Digital Noise Reduction)

Digital noise reduction is the process of applying a filter to the image to reduce noise from the video signal. You can choose the strength of the filter from Low, Middle and High.

Privacy

Allows the user to “**block out**” up to 16 areas in the picture so that the installation complies with the Data Protection Act and avoids infringing other people's privacy rights. This could be used to block out windows on a neighbouring property or screens and signs that display sensitive information.

D-Zoom

Enables the user to digitally zoom in on an area of the image if the optical lens is not quite enough. PIP (Picture In Picture) can be enabled so that a small window showing the original size image is overlaid onto the screen when zoomed in. It detects movement in a certain area. This can be used to get a closer view of faces or number plates.

Every TVision camera is built to the highest standards and fully tested prior to packing. If you experience an problems you need to investigate your cabling, connections, power supply and monitor.

No Picture From The HD-TVI

There are a number of potential problems that could cause this.

1. Power Supply

The camera can not function without the correct power supply.

- A.** Test that the camera has the correct voltage supplying it, you must do this with the camera connected so that there is load on the PSU. A 12V DC camera should have at least 10.5V DC connected to it. 24V AC cameras should have at least 21.5V AC connected to them.
- B.** For 12V DC cameras only ever use regulated power supplies so that you can be sure that the camera is always receiving the correct voltage.

Tip

See online [Tip 259](#) for the 'Dos And Don'ts Of Power Supplies' at www.tvision.technology.

2. Cabling

Check there is a picture coming out of the CVBS test output at the camera. If there is a picture here but not at the DVR it could be one of the following:

- A.** Video loss in composite cable as the run is too long. Usually you would get a picture up to around 500m with HD-TVI.
- B.** Check the quality of the cable used. For best results, especially with HD-TVI, use a cable with a solid copper core such as our [Antihum branded cable](#) on [page 40](#). Cable with a solid copper core suffers far less signal loss than cheaper, inferior cable which only has a copper coated core.
- C.** Ensure that the BNC - BNC lead that you connect between the camera and monitor has no shorts or open circuits. If you are making your own lead, don't forget the lead must have two wires connected to complete the circuit, Video and Ground.
- D.** Ensure all connections to both the camera and DVR are firm and secure.

Continued on the next page ▼

- E. Make sure that there are no tight bends or loops in the cable. The minimum bend radius for RG59 co-ax cable is 60mm.

Tip

See online [Tip 300](#) for our 'Top Tips When Installing Cable' and [Tip 281](#) for the 'Dos And Don'ts For Running Co-ax' at www.tvision.technology.

From the DVR's menu system enter the PTZ settings and change the protocol of the channel(s) required to 'TVI Coaxitron'.

For example on an alienDVR enter the 'Video' menu, select the 'PTZ' tab and click 'PTZ Settings'. Click the protocol drop-down list and select 'AlienTVI Coaxitron'.

Test Monitor Does Not Display An Image

Make sure the test monitor is connected to the camera's CVBS (analogue) output and not the HD-TVI output. Most test monitors do not accept HD-TVI signals.

Up The Co-ax Control Does Not Work

To setup the camera using up the Co-ax control you need to display the PTZ controls during live view mode on the DVR ([See page 28](#)).

If you can not access the camera's menu using the PTZ controls, the PTZ protocol may be set incorrectly on the DVR.

11 Reasons the alien MEGA Hero™ is great value for money



1. **An Easy Upgrade Path** - HD-TVI uses standard RG59 75 ohm CO-AX cable so no need to re-cable for an upgrade.
2. **No Network Configuration or Modification is Required** - less call backs to a network that you didn't install.
3. **Standalone so Immune to Network Interruptions** - only needs connection to the customer's router.
4. **Near Zero Latency (Video Delay)** - so no dreaded buffering effect on your recordings.
5. **High Resolution Images** - HD-TVI offers 20x the picture quality of a basic analogue (CIF quality) recorder.
6. **Global Non-proprietary System** - so more equipment choice and the prices aren't held artificially.
7. **Reliable** - by choosing good quality RG59 cable, the camera's HD signal does not need compressing like an IP camera.
8. **TVI has a High Resistance to EM Interference** - so much longer cabling runs (up to 500m).
9. **Plug and Play** - Co-ax cable and BNCs make installation simple for installers, no network knowledge is required.
10. **Future-proof Triple Technology** - triple technology allows analogue, IP and HD-TVI to be used in the same unit.
11. **TVI 2.0 Technology** - makes HD cameras and DVRs even more affordable & reliable.

Mini 1ch HD-TVI Passive Baluns (Pair)



ZENDit™

- Transmit Up To 200m Over CAT5
- No Power Required
- Screw Terminals For Easy Connection
- Just 31 x 25 x 15mm

Order Code: **BAL702**

1ch HD-TVI Baluns - Video, Power & Data (Pair)



ZENDit™

- Send Video, Power & Data Or Audio
- Transmit Up To 200m Over CAT5
- No Power Required
- Spring Clamp Terminals For Easy Connection

Order Code: **BAL810**

1ch HD-TVI Passive Pigtail Baluns (Pair)



ZENDit™

- Snap Together Design To Form Single Block
- Transmit Up To 200m Over CAT5
- No Power Required
- Spring Clamp Terminals For Easy Connection

Order Code: **BAL806**

8ch Wall-mount HD-TVI Passive Balun



ZENDit™

- 36MHz Video Bandwidth
- Transmit Up To 200m Over CAT5
- No Power Required
- Screw Terminals & RJ45 Sockets For Easy Connection

Order Code: **BAL908**

HD-TVI & Analogue CCTV Test Monitor

cctvmate.com



- 7" TFT LCD Display
- TVI Coaxitron Support
- BNC, VGA & HDMI Inputs
- 12.6V DC Li-ion Battery

Get the best of both worlds with this 7" test monitor which tests standard analogue and the latest HD-TVI cameras.

Order Code: **LCD380**

HDMI Distributors - 2, 4 & 8 Way

ScatterBox™
..distributes signals



- 1 HDMI Input
- Up To 8 Outputs
- 12V DC PSU Supplied
- Wall-mount Design

Quality HDMI splitters for viewing the same image on multiple monitors. The HDM312 and 314 even have a built-in IR extenders.

- 1 In / 2 Out With IR Extender: **HDM312**
- 1 In / 4 Out With IR Extender: **HDM314**
- 1 In / 8 Out: **HDM308**

VoiceOff Voice Annunciator



VoiceOFF
com

ATTENTION!
"You are being
Recorded On CCTV
Please leave the area"

- Trigger Up To 9999 Sounds
- 10 Alarm Inputs Trigger 10 Recordable Warnings
- Removable SD Card
- Talkback Function
- Weatherproof
- RS485 & RS232 Connection
- Activate Remotely Over The Internet
- Built-in Relay
- Additional Sound Files Can Be Downloaded at www.voiceoff.com

The VoiceOff is an alarm activated voice or sound warning unit that has 10 separate alarm inputs, to trigger up to 10 different recorded sound files. RS485 and RS232 inputs trigger up to 9999 sounds! Over 1000 pre-recorded sounds and messages are available for use at voiceoff.com.

Warning messages can be downloaded or recorded in MP3 format and stored on the removable SD card. These sounds can be used to welcome visitors, deter intruders, warn or inform people as they enter certain areas.

Order Code: **VOX300**

Pre-Printed CCTV Warning Signs



- Unique sign ID & QR Code
- Anti Glare Plastic
- AntiFade Ink
- Data Compliant Ready
- Pre-drilled Mounting Holes
- Rounded Corners
- Weatherproof

The Who Is Watching Me signage provides an off-the-shelf solution for CCTV scheme operators.

The unique serial numbered signage and website registration process allows CCTV system operators to supply their contact details to members of the general public without the need for expensive personalised signage. This is essential in helping ensure you comply with the Data Protection Act! The scheme operators can amend their contact personnel details when staff leave the company, update contact telephone numbers or e-mail addresses at no extra cost to themselves. Members of the general public can enter the unique serial code on the sign on www.whoiswatchingme.org to find out the scheme operators details. This avoids having to have individual signs made for each client meaning a lower cost for you!

A4 Sign: **SIG550**

A3 Sign: **SIG650**

AlienCCTV HDMI & TVI Monitor



- HD-TVI, CVBS, HDMI & VGA Inputs
- Full HD 1920 x 1080 (21.5" & 24")
- LED Backlight
- Anti-glare

Order Code: **LCD921** (21.5")

3pc BNC Crimps



Use with the Crimp Tool below!

- Popular Connectors
- 3 Piece Design

These traditional 3-piece BNC crimp-on plugs are the popular choice for CCTV Installers.

100pk Order Code: **CON430**

Antihum RG59+2

Cables can be separated for fast, easy installation

Glued foil sheath provides maximum protection against interference and prevents "loose" foil shorting to the centre pin

0.7mm centre core for maximum performance and long runs.

Black or white PVC

0.15mm x 24 Copper power cores for powering the camera

Black 100m Order Code: **CAB054**
White 100m Order Code: **CAB040**

Ratchet Crimp Tool



- Crimps 2pc, 3pc & Mini
- Essential For Installers

Essential kit when making your own cables. The crimp tool is designed to crimp 2pc, 3pc and mini 3pc BNCs.

Tip

See online **Tip 259** on 'How To Crimp 3pc BNCs'

Order Code: **TOO980**

5-Amp 12V DC PSU With 9 Outputs



- 5A Overall Output
- 9x 12V DC Outputs

Regulated 12V DC 5 Amp PSU with multiple outputs for use with up to 9 suitable CCTV cameras. Each output produces up to 1 Amp (Max 5A overall outputs) to suit most cameras and housings.

Order Code: **POW400**

Megapixel Direct Drive Lenses



- Mega Pixel Lens
- Choice Of Lens Size

Megapixel direct drive lenses offer the lens quality needed to capture stunning HD images.

3.5-8mm DC Iris 1/3": **MPL300**
 2.8-12mm DC Iris 1/3": **MPL312**
 5-50mm DC Iris 1/3": **MPL350**

Interceptor CCTV Housing Kit



- Heated Housing & Bracket
- Unique Warning Signs
- Fixings Included

Attractive housing, dual voltage, low current heater, strong cable managed bracket, accessories and fixings tub, 3x A4 CCTV warning signs with free registration onto the Who Is Watching Me data compliance scheme.

Order Code: **CCT470**

Installer details:

All specifications are approximate. We reserve the right to change any product specifications or features without notice. Whilst every effort is made to ensure that these instructions are complete and accurate, TVision cannot be held responsible in any way for any losses, no matter how they arise, from errors or omissions in these instructions, or the performance or non-performance of the equipment that these instructions refer to.



WEE/CG0783SS

This symbol on the products and/or accompanying documents means that used electronic equipment must not be mixed with general household waste. For treatment, recovery and recycling please return this unit to your trade supplier or local designated collection point as defined by your local council.