



Instruction Manual

SEE705

© 2023 System Q Ltd

ZipNVR.com

Table of Contents

Part 1 Introduction	1
1 SEE705	1
Part 2 Tools & Handy Extras	1
Part 3 Connections	2
Part 4 OSD 4-In-1 Technology	2
Part 5 Mounting	3
1 NiteDevil Eyeball	3
Part 6 OSD Menu	4
1 5MP OSD Menu	5
2 Key Menu Settings	6
Part 7 Audio Over COAX	7
Part 8 Troubleshooting	8
1 Camera Rebooting / Turning Off	8
2 Poor Quality Images	8
3 Image is Black & White	8
4 NCD / No Image Displayed on Recorder	8
Part 9 General Maintenance	9
Part 10 Specification	10
1 SEE705	10
Part 11 Conditions	11
1 General Company Disclaimer	11
2 WEEE Declaration	11
3 Copyright	11
Index	13

Introduction

1.1 SEE705

The all new NiteDevil® 24C can stay in full colour around the clock using the minimal amount of natural light to produce superb full colour images. It really is a game changer in performance and should be used as a part of any CCTV system requiring full colour images in key areas around entrances etc.

With built in dual IR and white light you can choose how the camera best works in your install. Using white light to give visual warning or using IR illumination to get a more discreet set up.

A built in microphone means you can see and hear what's happening, recording the audio & video on your ZIP SUPA-S DVR for the best possible CCTV evidence.

Tools & Handy Extras

- Screwdriver
- Drill
- 12V DC PSU
- Drill bits
- BNC Crimp Tool & BNCs
- RG59 Coax Cable
- Digital Multi-Meter
- LCD400K - CCTV Test monitor

Connections

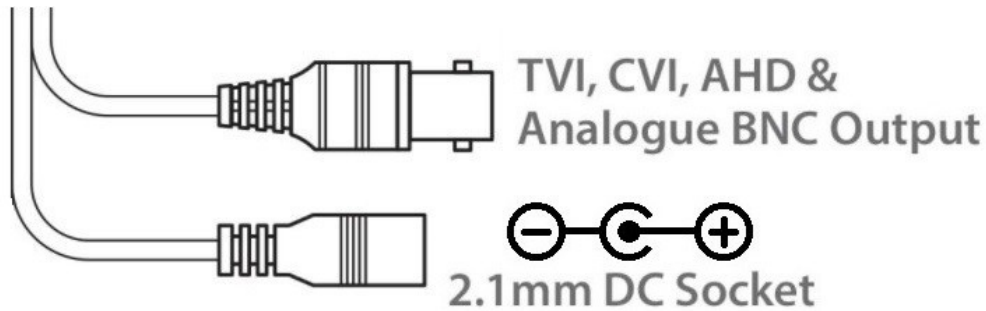

The camera has a 2.1mm socket which requires 12V DC, use a regulated power supply rated above the current draw of the camera.

The camera is polarity sensitive so connections must be correctly made.

The camera has a standard BNC connector for video output, the output can be changed to AHD, CVI or CVBS if required in the menu

OSD 4-In-1 Technology

Selectable HD-TVI, HD-CVI, AHD and CVBS (Analogue) Output. As default the camera is set to HD-TVI, however the output can be changed to AHD, CVI or CVBS if required.

This output can be changed with in the menu camera. Please note the "Mode" in the menu of the DVR won't change the format, as the menu overrides the output.

See [OSD Menu](#) for accessing and changing the video format.

Mounting

5.1 NiteDevil Eyeball

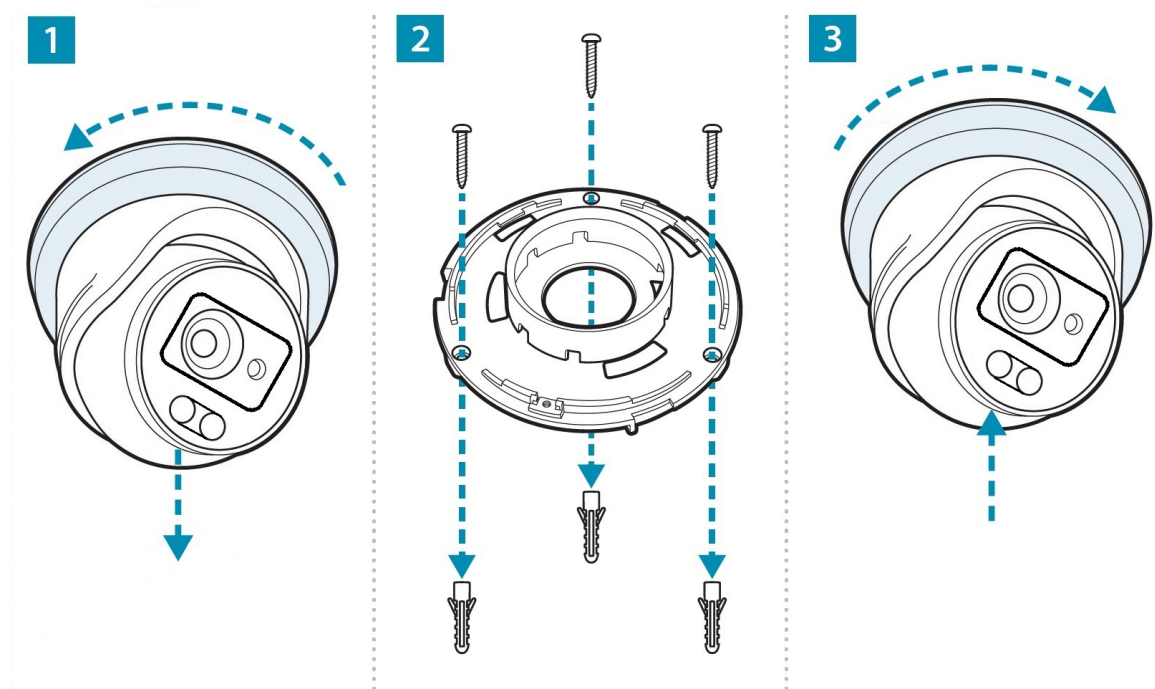

A template is provided in the box for marking the hole positions for the fixing screws.

OSD Menu

Access to the camera menu is by Coaxitron. For the ZIP DVRs, ZIP Coaxitron is set as default.

To access the Cameras Menu via coaxitron:-



1. Click on the image in Live view
2. Click on the PTZ button at the bottom of the screen
3. Click on the IRIS + / centre button to display the menu

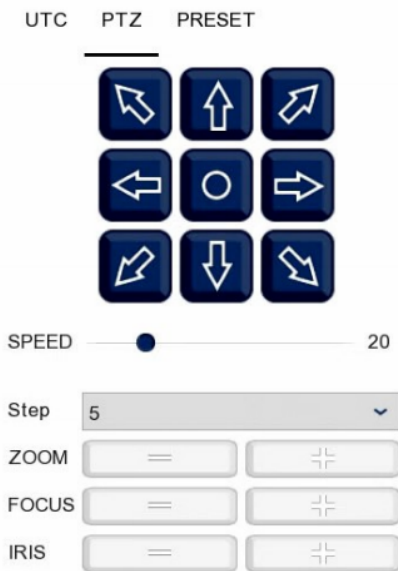

Use the directional arrows to move up and down through the menu.
 Use the directional arrows left and right to change the option.
 Use IRIS + to select & enter that menu option.

6.1 5MP OSD Menu

Video Mode	TVI / AHD / CVI / CVBS	
Format	5M20 / 4M25 / 4M30 / 2M25 / 2M30	
Language	English / Spanish / French / Chinese	
Exposure	Exposure Mode	Global
	AGC	High / Middle / Low
	Back	
	Exit	
	Save – Exit	
Day & Night	Mode	Ext / Color / B/W
	Dim	0 – 3 (3 Default)
	Back	
	Exit	
	Save – Exit	
Video Settings	AWB	Auto
	Brightness	1 -9 (5 Default)
	Contrast	1 -9 (5 Default)
	Sharpness	1 -9 (5 Default)
	Saturation	1 -9 (5 Default)
	NR	1 -9 (5 Default)
	Mirror	Default / Mirror / Flip / Rotate
	Back	
	Exit	
	Save – Exit	
Volume	0 – 9 (9 Default)	
Reset		
Exit		
Save – Exit		

6.2 Key Menu Settings

Exposure Mode - AUTO / GLOBE / GLOBAL sets the required shutter speed for the current light level. The shutter speed will automatically detect the required length of time to keep the digital sensor exposed to light. FLK option sets the shutter speed to stop synchronisation with lighting so that pulsing effect is minimised.

White Balance - Colour adjustment of the camera to be set up so objects appear a natural colour. ATW / PRO (Automatic tracking white balance) continually tracks and adjusts the white balance, making it suitable for use in cameras in which the image content and lighting are subject to changes.

Day & Night - The camera can be set to colour or B&W mode or have it automatically switch External is set as default, the switch between colour and black & white is controlled by an external trigger In this a light dependent resistor.

DNR (Noise Reduction) - Noise Reduction is the process of removing noise from the video signal by applying a digital filter. 2D noise reduction reduces noise in the foreground of the image where as 3D noise reduction reduces noise in both the foreground and the background of the image.

D-WDR - Digitally adjusts the exposure in areas of the frame to maintain optimum levels in both the dark and bright areas of an image.

NOTE - Some models may not have D-WDR function.

Reset - Defaults the camera to factory settings. This setting helps when fault finding issues with the camera to ensure all settings are defaulted.

Audio Over COAX

The Audio over COAX (Coaxial Audio) is compatible with the ZIP SUPA-S & XTRA204-216 range of recorders.

Setting the Input type determines which audio inputs are used.

Base-band Audio - Sets the audio type to the physical RCA Phono type connection on the back of the recorder. This type of audio input requires a audio input connection or microphone to be wired into the back of the recorder.

Coaxial Audio - In order to use compatible Zip audio of coax cameras, coaxial audio needs to be set. The audio is captured at the camera and then set along side the video and then decoded in the recorder.

Ensure Audio (Volume) is enabled for each channel in the record menu to record the audio with footage to then playback. If not the audio will only be heard when looking at the live view / preview on the DVR or via the Zip Vision Pro App.

Set this in [Record - Encode - Mainstream](#) and [Record - Encode - Substream](#)

**Note the V1 SUPA & XTRA recorders are not compatible with Audio over COAX.*

To enable, in the menu on the SUPA-S go to **System > General > Audio Input Type**

Select Coaxial Audio

Select Apply

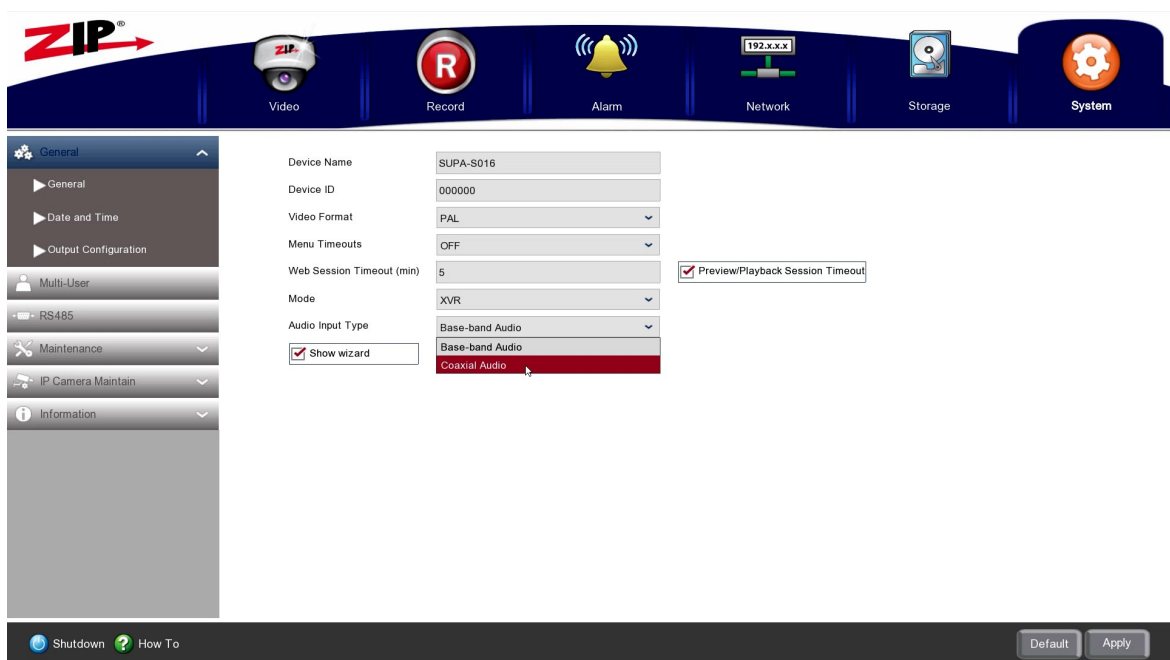

Troubleshooting

8.1 Camera Rebooting / Turning Off

- A. Check the voltage to the camera (under load) using a digital multi-meter, if below 10.8V then move the power supply closer to the camera.
- B. For 12V DC cameras, only use regulated power supply rated above the current consumption, so that the camera is always receiving the correct supply which is rated above the current consumption.
- C. Use thicker gauge copper cabling to reduce the voltage drop to the camera, using thicker cable will reduce the resistance between the camera and the power supply and therefore reduce the voltage dropped along the cable.

8.2 Poor Quality Images

- A. Check the video format the DVR (digital video recorder), then set the camera to the relevant video format – see the 4-In-1 Technology
- B. If set to CVBS, then this is a low quality video output for legacy systems (analogue - CVBS), when using a 2 MegaPixel DVR or above then use another video format, like HD-TVI.
- C. Reset the camera menu via Zip Coaxitron – [OSD Menu](#) 
- D. Check if the DVR (digital video recorder) supports the resolution of the camera.

8.3 Image is Black & White

- A. Check the video format your DVR supports, then set the camera to the relevant video format – see the 4-In-1 Technology
- B. Reset the camera menu via Zip Coaxitron [OSD Menu](#) 
- D. Check if the DVR (digital video recorder) supports the resolution of the camera.

8.4 NCD / No Image Displayed on Recorder

- A. Check the voltage to the camera (under load) using a digital multi-meter, if below 10.8V then move the power supply closer to the camera.
- B. For 12V DC cameras, only use regulated power supply rated above the current consumption, so that the camera is always receiving the correct supply which is rated above the current consumption.
- C. Use thicker gauge copper cabling to reduce the voltage drop to the camera, using thicker cable will reduce the resistance between the camera and the power supply and therefore reduce the voltage dropped along the cable.

D. Ensure that the BNC – BNC lead that is connected between the camera and DVR has no shorts between the ground and the centre core (positive) or open circuits along the centre core (positive) or open circuits along the ground.

General Maintenance

- Routinely clean the camera to prevent dust build up as this can effect the performance of the camera. It is recommended to use a damp non-abrasive microfibre cloth.
- Routinely check the connections for power and data to ensure no water ingress and corrosion.
- Check that the cameras are firmly attached to the wall or mounting bracket.
- Check playback in the recorder to ensure the camera is recording and triggering properly.

Specification

10.1 SEE705

Resolution	5MP
Lens Type	2.8mm Fixed Lens
Image Output	1 Volt Peak-Peak 75 ohm
Min.Illumination	0 Lux IR On
Day/Night	24C / Mechanical IR (True Day-Night)
InfraRed LEDs	2 White LEDs / 2 IR LEDs
IR Range	20M
Audio	Built In Mic (Audio over COAX)
Input Voltage	12V DC
Current Consumption	300mA (IR On)
IP Rating	IP66
Video Connection	BNC Socket
Power Connection	2.1mm DC Socket
Finish	White/ Black
Build	Metal
Dimensions	100mm (Diameter) x 90 mm (Height)

Conditions

11.1 General Company Disclaimer

All specifications are approximate. System Q Ltd reserves the right to change any product specifications or features without notice. Whilst every effort is made to ensure that these instructions are complete and accurate, System Q Ltd cannot be held responsible in any way for any losses, no matter how they arise, from errors or omissions in these instructions, or the performance or non-performance of the equipment that these instructions refer to.

11.2 WEEE Declaration



This symbol on the products and/or accompanying documents means that used electronic equipment must not be mixed with general household waste. For treatment, recovery and recycling please return this unit to your trade supplier or local designated WEE/CG0783SS collection point as defined by your local council.

11.3 Copyright

© Copyright 2023

Zip is a registered trademark of System Q Ltd, Chesterfield. Derbyshire. S40 2WB

Index

- A -

Adjustment 4

- C -

Cleaning 9

Connections 9

Copyright 11

- D -

Declaration 11

Dimensions 10

Disclaimer 11

- G -

General Disclaimer 11

- H -

Handy Extras 1

- M -

Maintenance 9

Mounting 3

- O -

OSD Menu 4

- S -

Settings 4

Specification 10

- T -

Tools 1

Troubleshooting 8

- V -

Video Loss 8

Voltage drop 8

- W -

WEEE Declaration 11