

## Varifocal Auto Iris With Anti-Vandal Features CCD Dome Camera

### Introduction

Each of the Varifocal anti-vandal domes is made from metal and polycarbonate so they are resistant to moderate impacts. For extra security you can also purchase the anti-tamper screw kit, which prevents unauthorised access, *order code CCT463*

Its tough outer shell is also weatherproofed so that the unit can be installed internally or externally when using the external weatherproof cable glands provided.

The Varifocal lens means that the cameras can be adjusted for a wide angle of view or a narrow angle distance shot so they can capture the exact scene your customer wants without you having to worry about what lens to order.

The cameras electronics have been designed around the latest semiconductor technology and circuit design to ensure that all three variants of the camera produce an excellent picture quality to match the cameras stunning looks.



### Features

- The combination of metal and polycarbonate give a tough anti-vandal dome camera
- Dual input supply, 12V DC or 24V AC power supply required
- The dome cover is secured with 4 x Allen screws (Allen key supplied) for a professional and more secure installation.
- With a 4 -9mm Vari-focal lens being fitted as standard the lens size guesswork for installations has been removed.
- Spare polycarbonate dome cover (clear) available. Vandalised domes can be repaired quickly minimising time and expense, *order code CCT464*
- Domes can be mounted internally or externally (fitted with gaskets as standard)
- Supplied with a mounting plate for secure fix on suspended/false ceilings. (Fixing screws for the dome and plate included)
- Nylon retaining strap between cover and base for added safety during installation and/or servicing.
- Video and power connected via a flying lead. The video is via a female BNC connector. The power is via a 2-way connector (cable mounted plug fitted and the socket is included) to reduce installation time.
- Rubber base gasket supplied to fit between the base and mounting surface of the dome. Helps to prevent dust and moisture ingress.
- Fixing template included. (Label showing the domes fixing hole positions)

**Note:** The Fixing hole diameter for the flush mount range is 90mm

### Models Covered in these instructions

CCT465	Flush Mount Hi-Res B&W with Vari-Focal Lens
CCT467	Flush Mount Mid-Res Colour Dome with Vari-Focal Lens
CCT469	Flush Mount Hi-Res Colour Dome With Vari-Focal Lens
CCT475	Surface Mount Hi-Res B&W Dome with Vari-Focal Lens
CCT477	Surface Mount Mid-Res Colour Dome with Vari-Focal Lens
CCT479	Surface Mount Hi-Res Colour Dome with Vari-Focal Lens

**Camera Specifications**

Camera Spec	CCT465/CCT475	CCT467/CCT477	CCT469/CCT479
	Hi-Res B&W	Med-Res Colour	Hi-Res Colour
Image Sensor	1/3" B&W	1/3" Col. Sharp	1/3" Col. SONY Ex View
Image Output	1V <sub>pk-pk</sub> 75Ω	1V <sub>pk-pk</sub> 75Ω	1V <sub>pk-pk</sub> 75Ω
Resolution	600TVL min	380TVL min	480TVL min
Min Illumination	0.03 Lux	0.5 Lux	0.25 Lux
Input Voltage Range	12V DC / 24V AC	12V DC / 24V AC	12V DC / 24V AC
Power Consumption	200/100 mA	200/100 mA	200/100 mA
Lens	4-9mm Vari-focal	4-9mm Vari-focal	4-9mm Vari-focal
AGC	Automatic	Automatic	Automatic
Iris Control	Auto Iris	Auto Iris	Auto Iris
Size	W125 x D125 x H95mm	W125 x D125 x H95mm	W125 x D125 x H95mm

**Powering the Camera**

The dome cameras are dual voltage i.e. you can use them on a 12V DC system or a 24V AC system. The camera has built in power supply control circuit for ease of connection; this means that you can connect to any 12VDC or 24VAC system without worrying about polarity or voltage regulation.

The camera is provided with a screw terminal on a fly lead that allows you to connect the power supply to it. When powering the camera with a 12V DC power supply, ensure that the supply is regulated and has a continuous rating of 100mA or higher per camera. It is recommended to use a power supply that is rated higher than the current consumption of the camera i.e. POW100 would be adequate for powering a single camera but when powering two or more you should look at the bigger power supplies that are available from System Q; this prevents the PSU from running at its maximum rating for long periods of time.

If you are using the System Q Easy Connection Kit (CCT806/7) to power and connect your camera (12V models only) please proceed as per the instructions supplied with The Easy Connection Kit. You will need to cut off the DC Plug ONLY and use the bare wires to connect to the terminal strip. The 12V positive is the RED wire the 0V is the BLACK wire.

**Using 24V AC power**

Using a suitable cable between the 24V AC power supply (POW600) and the camera you can connect the power to the cameras terminal strip either way around. As the power is 24V AC, (alternating current), the polarity is not important. You must use a separate cable for power and video. It is recommended you use a 2/4-core cable to carry the AC power to the camera and use an RG59 or twisted pair cable to bring the video signal back from the camera to the monitor / control equipment.

**Connecting the camera to control equipment.**

The dome camera comes with a fly lead for power and video out. To reduce installation time the video out lead is terminated into a male BNC connector. This allows the installer to effortlessly connect the camera to control equipment via a female BNC-BNC lead.

Remember that the Video out from the camera is like any other electrical circuit and requires two wires to complete the circuit. When using a co-ax type cable such as RG59 or similar, the outer braid of the co-ax provides the "0V GROUND" connection and the inner core provides the "Video" connection.

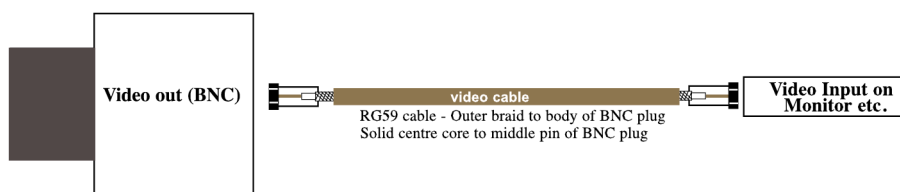

It is recommended that when you are first setting up the cameras that you use a short BNC-BNC cable to link the camera directly to the monitor and to set it up at the same time. This allows you to both understand

the camera and get the very best out of this great product, as you will be able to adjust the camera whilst looking at the monitor screen. Obviously whilst you are setting up the camera, it does need to be powered!

### **Lens Adjustment**

When setting the lens to suit your particular application, remove the cover and inner lens surround, loosen off the locking screws and alter the focal / Tele/wide adjustments. When the desired picture is achieved tighten the locking screws and replace the covers.

There are two sections to the lens that can be modified, the focal adjustment that allows you to alter the position of the focal lens in order to focus the lens. The Tele/wide adjustment allows you to achieve the required angle.

*Hint: When you are setting up the cameras on site it pays to have a test monitor with you so that whilst you are up ladders, you can position the lens without having to go up and down to the monitor to check on the camera setting. CCT020 4" LCD Test Monitor or the CCT021 6.8" LCD Test Monitor*

### **Accessing the Dome Camera**

(For Lens adjustments and Dipswitch settings, Figure 3 and Table 1)

Refer to Figure 1

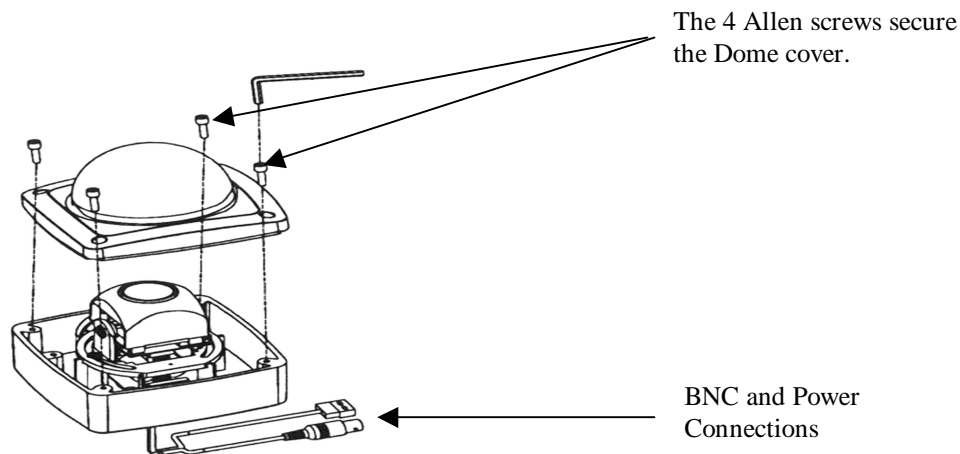
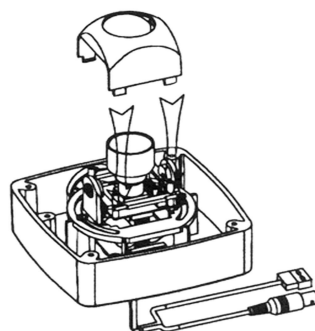

**Figure 1**

Using the Allen key provided with the Dome, undo and remove the 4 Allen screws. The dome cover can now be lifted clear of the housing giving access to the camera lens and PCB.

### **Adjusting the Lens settings.**

The black plastic cover lifts off of the camera. It is held by 4 plastic lugs and just needs easing from its mountings and lifting upwards to expose the camera PCB, switches and the lens focus and zoom controls. (Refer to Figure 2)



**Figure 2**

The pins adjust the focus and the angle of view or tele/wide angles. To change the focus or angle the pins need to be loosened by turning them counter clockwise. When the correct focus and picture is achieved then re-tighten the locking screws to hold the settings in place. See Figure 3 for the lens pin locations.

**The Dipswitch settings**

(Refer to figure 4 and Table1)

The dipswitches are numbered 1-3. There are 2 positions for the dipswitches, either ON or OFF. Switches 1 and 2 are for the Auto-Iris settings of the lens. Switch 3 is for the BLC (Back Light Compensation).

The common settings for the switches when the Auto Iris lens is fitted are shown in Figure 4 (Please Note that this lens is fitted as standard)  
(Please refer to Table 1 for the complete dipswitch settings.)

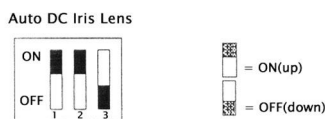

**Figure 3**

**Table 1**

Function	SW1	SW2
<b>Electronic Iris (ESC)</b>	OFF	OFF
<b>AUTO IRIS (ALC)</b>	ON	ON
<b>FL (Flicker Less)</b>	OFF	ON
<b>SW3= BLC</b>	OFF= BLC is OFF	ON = BLC is ON

**ESC**

The electronic iris setting would be used if a standard or manual iris lens is being used. This relies on the electronics built into the camera PCB to electronically set the correct picture brightness.

**ALC**

The Auto Iris setting is used when the lens has the Automatic Iris function. This is fitted as standard on the camera. The ALC control may need to be adjusted for this lens if the picture is too bright or poor at night. This control is only effective when the Auto Iris lens is fitted and the dipswitches set accordingly. (See the Automatic Level Control section for further details)

**FL**

The FL or Flicker Less switch is used if there appears to be 'pulsing' or 'flickering' on the picture. Setting the switches as in table 1 (SW1 OFF and SW2 ON) removes the problem.

**Back Light Compensation (BLC)**

This option can help when there is something bright in the main picture such as an external window. The symptoms may show some of the objects in the picture as silhouettes. Setting this to ON allows the lens to compensate for the bright part of the picture so that the surrounding area of the picture is not too dark.

**Automatic Level Control (ALC)**

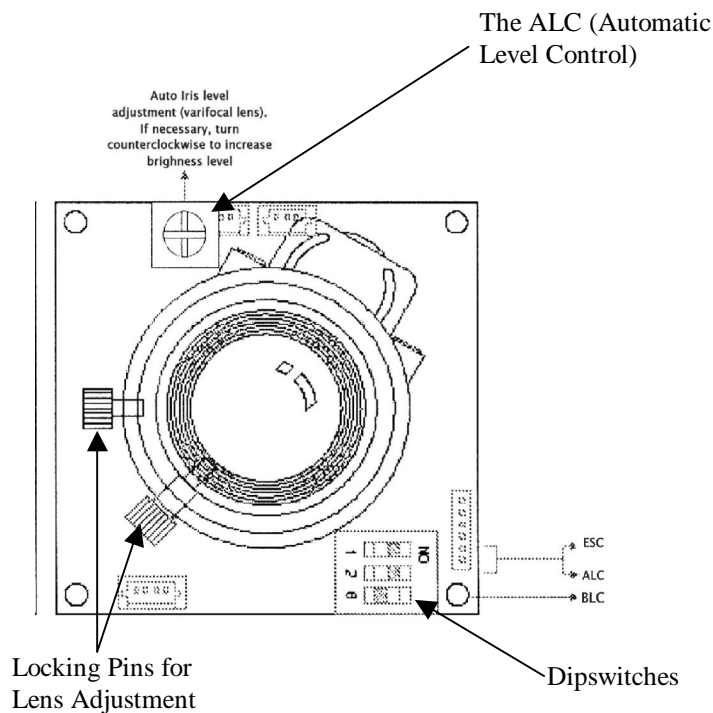

Figure 4

Note: If the camera is giving satisfactory pictures then there is no need to adjust the ALC control. The ALC setting determines when the IRIS of a lens opens and closes. Turning the control counter clockwise allows the IRIS to open, which in turn allows in more light producing a brighter picture. Turning the control clockwise allows the IRIS to close producing a dark picture. The best way to set up the ALC is with the camera in the brightest light conditions that it will be operating in i.e. sunlight and keep the IRIS open to its maximum without giving too bright a picture. This means at low light levels the IRIS will be as open as possible giving the best results.

**Use the following method to adjust the ALC control.**

**Tip:**

Set-up the ALC with the camera in its brightest working conditions. This will give the best overall operation of the Iris for varying light levels.

1. Turn the ALC control fully counter clockwise. The picture on the monitor should be very bright or white.
2. Slowly turn the ALC control clockwise until the picture is as required.

### Installation Overview

**Installation Tips:**

**Tip 1:** With reference to the Internal gasket that seals between the domes cover and base. Spread a thin coat of silicon grease onto the lip of the dome and seal prior to fixing the cover (this is a simple precautionary measure that will assist the seals properties and also aid removal for future servicing).

**Tip 2:** With reference to the rubber grommet that is used for cable entry. Use silicon sealant or another type of sealant with the same or similar properties to seal around the cables and entry hole.

Figure 5 below shows you how to replace the polycarbonate dome insert – order code CCT464

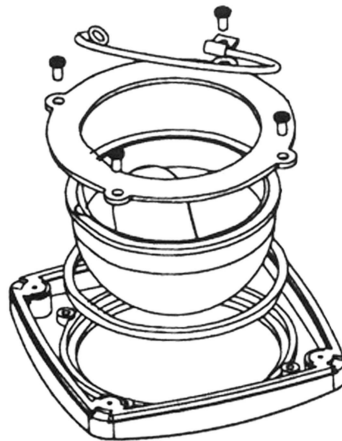

Figure 5

Figure 6 below gives a diagrammatic representation of how to fasten the Dome to a false/suspended ceiling.

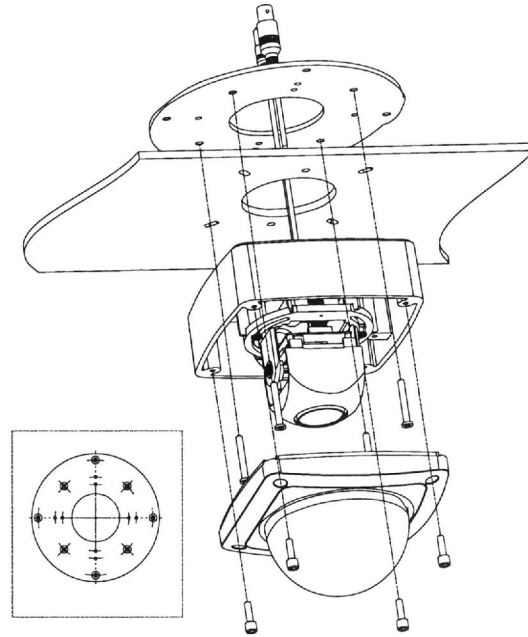

Figure 6

### Trouble-shooting Tips

#### Picture too bright or dark:

- The ALC control is set incorrectly
- The BLC switch needs setting
- The camera is set for Electronic Iris and not Auto Iris

#### No Picture.

- Check the supply voltage to the camera. This can be anywhere between 12-24volts ac/dc
- Check the BNC video lead connection. Remember that like any other electrical system the video signal requires a 2-wire connection. The centre core carries the video signal and the outer core or screen is the 'video signal return'

#### Poor Night Time Pictures:

- Check the dipswitch configuration, the camera is supplied with an auto iris lens as standard and they should be set for Auto Iris and not Electronic Iris.
- Check the set-up of the camera in its brightest operating conditions and adjust the ALC control as described in the instructions.
- Check there is sufficient lighting available for the area under observation, if it is not possible to see anything in the dark yourself it is unlikely that the camera will see anything either. **TIP: Take a lead lamp to the sight and try recording the picture with the light in different places; this will help solve or highlight any lighting issues.**

#### Poor Focus:

- Check the lens adjustments for focus and set for best possible picture as required.

- Check the ALC control. This controls the iris aperture and if it is too open then the picture will not be sharp. This is best set-up in the brightest operating conditions. See the ALC section.
- Check that the dome cover is clean.
- Check that there is or has been no moisture ingress through a poor seal or cable entry. This usually leaves tell tale smears on the inside of the dome cover.