

Features

- Multi-purpose
- Two independent channels
- Four output modes: mimic, delay, toggle, latch
- Relay contacts on each channel (12-24Vdc 10A)
- Normally Open (NO), Normally Closed (NC) contacts
- Screw terminals for easy connection
- High rejection of unwanted RF signals
- High sensitivity for increased range (up to 45M)
- Simple to set up and use
- 12V input for maximum compatibility
- Twin LED indication of RF activity/mode
- Optional receiver Dipole aerial for up 300mtr range



The key fob kit may be used in many different applications to control various pieces of security equipment e.g.: CCTV cameras, garage doors, floodlights, security gates, and bell boxes. The Kit consists of 1 key fob type transmitter and one 12V operated receiver. Additional key fobs are available order code CCT896.

You can use the receiver to operate many electrical devices as the receiver uses voltage free contacts on its output. Each channel has a separate relay that has both normally open and normally closed contacts. There are several "modes" that the receiver can function these being, Mimic, Delay, Toggle and Latch. Whatever mode you choose to use, *the same mode* applies to both channels. It is not possible to have a different mode on separate channels.

The Key fob and receiver are supplied "unmatched". This means that the receiver does not yet know that the key fob is assigned to it. To match a key fob to a receiver you have to "teach" the receiver that the key fob is to be used with it. This is done by a simple procedure of programming the receiver. If in the future you add extra key fobs to your installation you must follow the same procedure with each new key fob. This procedure is outlined in "*Programming the receiver for the key fob*"

Please Note - To control mains voltages, the receiver will need an additional mains rated contactor or relay. Each receiver can learn the codes from 15 key fobs on each channel, therefore enabling a maximum of 30 key fobs per receiver.

Receiver Modes -

1. Mimic Mode
Press the key fob button and the receiver relay will be energised whilst the button is held down. Release the button and the relay drops out.
2. Delay Mode
Press the key fob button and the receiver relay will be energised for four seconds. Ideal for activating a short panic sounder or similar.
3. Toggle Mode
Press the key fob button and the receiver relay will be energised and stay energised until the button is pressed again – ideal for use with alarming/disarming burglar alarms.
4. Latch Mode
Press the key fob button and the receiver relay will be energised. Now, it can only be de-energised by removing power from it i.e. an engineer reset.

Getting Started

Sitting the Receiver - Obviously you first need to site the receiver. If for example you were using the receiver in a home then some central location would give the best chance for the key fob to operate from most places in the home. In this instance the loft may be a good place. Remember that solid walls and similar objects will "attenuate" (reduce) the key fob's signal so use some thought when sitting the receiver. You don't have to put the receiver next to the equipment you are trying to operate; you could in fact use an extension cable and have it a distance away that is better for receiving the key fob's signal.

Powering the receiver – The receiver needs 12V D.C to power it. This may be able to come off the equipment you are connecting it to or you may need a separate power supply. The receiver has two terminals clearly marked for the 12V input these are +12V and GND (OV Ground).

Programming the receiver for the key fob - With the receiver powered up you can now make the receiver “learn” what key fobs are associated with it.

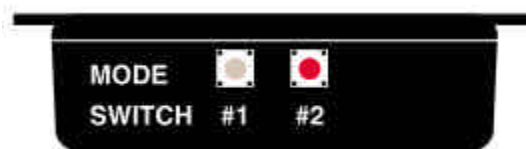

On the receiver there are two buttons, brown (#1) and red (#2). They represent the two channels of the receiver, this enables you to program a key fob button to operate the channel of your choice. The programming steps are;

- 1- Depending upon the channel you wish to program on the receiver press and hold the relevant button, either brown (#1) or red (#2) for approximately 3 seconds until the red or green LED starts to flash.
- 2- Press the relevant button on the key-fob. The LED will flash once then go off.
- 3- Now test the programming by pressing the button on the key fob again you should now operate the relay on the receiver and hear it click.

NOTE - The receiver channels can only be programmed one at a time.

Please watch the LED status on the receiver when you are programming it, as this will give you clues as to where you are in the programming cycle and if there is an error of some kind. The LED indicator is as follows;

Steady on	<i>RF activity</i>
Fast flash	<i>Learning mode</i>
On flash	<i>A button is learnt</i>
Two flashes	<i>Memory cleared</i>



If for any reason you fail to learn the code please repeat the above procedure, it is likely that you have taken too long on one particular stage and the receiver has timed out.



Setting up the correct mode for the receiver - The receiver has 4 different operating modes these being, Mimic, Delay, Toggle and Latch. You need to decide what mode you want for your particular application. NOTE - If you are using the receiver with the Advanced Vision CCT875 panel you need to leave the receiver in its factory default “Mimic Mode”

To change the mode simply locate the two wire links on the receiver's PCB and use the following table to select the correct mode and cut the appropriate link(s).

	LP1	LP2
Mimic	Uncut	Uncut
4 Sec Timer	Uncut	Cut
Toggle	Cut	Uncut
Latch	Cut	Cut

Connecting equipment to the Receiver – Many different types of equipment can be connected to the receiver. Some examples of use are shown in the following diagrams;

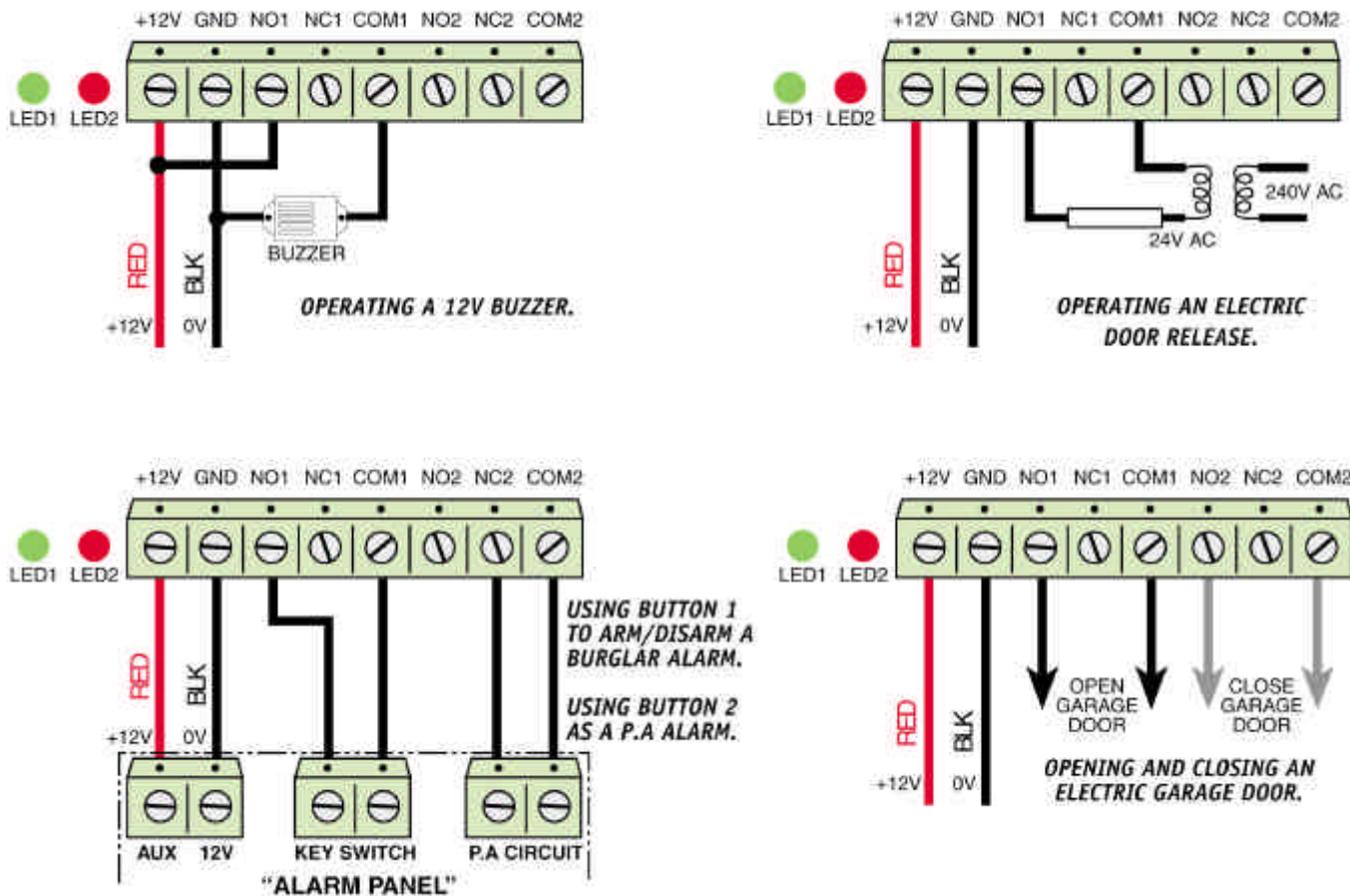

Extending or improving the range of the key fob.

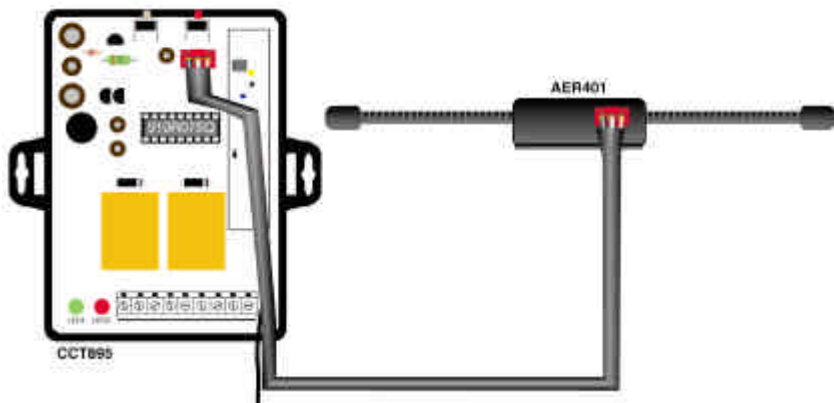

The maximum output power of the key fob is fixed so the only way to extend the range the two devices working together is to make the receiver more sensitive. To do this you can add an external dipole aerial (code AER401). This can extend the range up to about 300m in *ideal conditions*. Please remember solid obstacles will attenuate the key fobs signal and reduce the range. *Ideal conditions are direct line of sight with no obstacles in-between the key fob and the receiver.* The aerial needs to be fitted to the PCB receiver by removing the receiver lid and connecting as shown.

Using the Receiver with the CCT875 ADVANCED VISION CONTROL UNIT.

To use the receiver with the CCT875 control unit you need to follow the instruction on "Programming the receiver for the key fob" using the CCT875 to power the receiver. The method of connecting the receiver to the control unit is as follows.

This diagram illustrates how to connect the receiver to the CCT875 control panel. When used with the CCT875 controller it is wired to the Expansion port, the terminal block on the far right side of the controller.

The connections to this port are as follows:

- The +12 volt connects to Red terminal
- The 0 volts to the Black terminal
- Common 1 and 2 are linked to the Black or 0 volts terminal
- Normally Open 1 connects to the IN1 terminal (Blu)
- Normally Open 2 connects to the IN2 terminal (Whi)

To change the channel of the CCT875, press the key fob button once, the CCT875 will then display the relevant camera (1-4). To set the CCT875 into "auto-switch" mode press and hold the key fob button for approximately 3 seconds.

The second button can be used to control external lighting if you have a flood light controller connected to the CCT875.

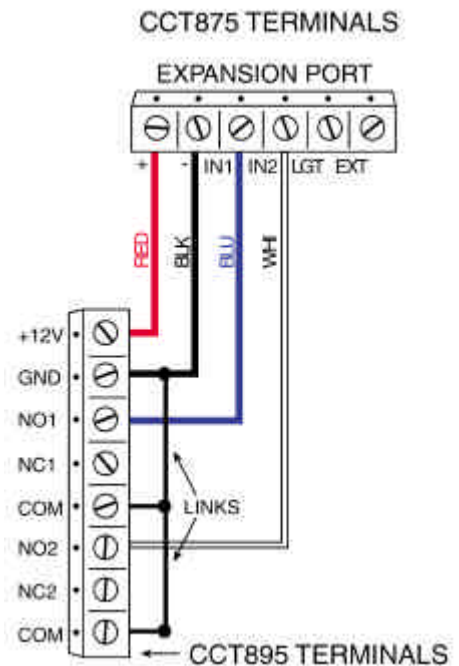

Fault Finding

Both the Key fob and receiver are very reliable and if you experience a problem installing or using either of these devices it is quite likely it is a simple installation error rather than faulty equipment. Please try and use the following notes to aid your faultfinding. Try all these solutions with the key fob near the receiver so you eliminate distance problems and can see and hear the receiver operate when you press the key fob button.

Problem - The receiver won't learn a new key fob code.

Answer – It is probably caused with you taking too long to follow the programming instructions and the receiver simply resets itself as it "thinks" you have abandoned the programming. To remedy this go to the programming procedure again and try to do each step swiftly. The LEDs on the receiver give visual indications that you have done each stage correctly. When it is programmed you should hear the relay "click" after you have pressed the key fob for about 1 second.

Also check – The key fob LED lights up indicating it is working and has a good battery.

Problem - Key fob operates receiver intermittently

Answer 1 – This is probably because the two devices are too far apart or there is something in-between them that stops the signal. Try moving the receiver to a more central location or indeed adding the dipole antenna that boost it reception signal. Remember that "foil backed" plasterboard will greatly reduce RF signals and therefore the range of key fobs.

Answer 2 – The key fob battery is low, please swap.

Problem – The receiver relays do not operate as expected.

Answer – you have probably selected the wrong mode by cutting the wrong link(s) please check.

Specification

Frequency	433.92Mhz
Transmission Range	Up to 45M, line of sight (up to 300M with dipole)
Channels	2 Independent
Receiver connections	Screw terminals
Output type	Two separate relays both with NO & NC contacts
Max Load	12-24V dc, 10A
Operating Current (receiver)	8mA 12V dc Standby; 60mA 12V dc per channel activated
Receiver size	85 x 70 x28mm
Key fob battery	L1028 supplied, re-order code BAT106

As per the European R&TTE Directive the part No CCT895 key fob has been declared license exempt as and when it is used as per these instructions. Modifications to the transmitter or receiver are not permitted.