

the excelPTZ range

Installation and Operation Manual

Six-inch *HIGH* Speed PTZ Dome with alarm inputs

Models covered (ALL 400 series PTZ400 – PTZ499)

PTZ400 22x HI-SP IVORY

PTZ405 22x IR HI-SP IVORY

PTZ406 22x IR-HR HI-SP IVORY

PTZ408 18x HI-SP IVORY

PTZ409 26x HI-SP IVORY

PTZ410 27x HI-SP IVORY

PTZ418 18x HI-SP SILVER

PTZ420 22x HI-SP SILVER

PTZ425 22x IR HI-SP SILVER

PTZ426 26x HI-SP SILVER

PTZ428 22x IR-HR HI-SP SILVER

PTZ430 27x HI-SP SILVER



Version 1.3

For updates to these instructions visit www.excelPTZ.com

CONTENTS TABLE

Description	Page No.
Contents	2
Safety Precautions	3
Key Functions	4
Special Dome Features – 4 channel alarm input activation & channel alarm output	5
Getting the dome up & running	6
Overview – introduction to fitting PTZ equipment	6
RS485 Wiring methods & Tips	8
Overcoming RS485 data loss using an RS485 distributor	11
Setting up the Dome Camera	13
RS485 connection – Connecting the Keypad or DVR to the Dome	14
Connecting the video out of the dome	16
If you are using more than one dome on a site	18
Setting up a unique address in a dome	18
Setup of the Protocol and the Default Baud Rate	19
Using the CCT786 and CCT768 keypad with the excelPTZ series	21
Presets and other functions	22
Patrols (Tours) – How to set them up and use them	23
Auto Scan – How to set it up – Calling the Auto Scan	26
Record Pattern – What is a record pattern?	27
What is the difference between a pattern & a patrol (tour)?	27
How to set it up – Running the Record Pattern	27
Using the Dome's Advanced Functions	29
Using the Advanced Menu System	30
Display Setup	31
Camera Setup	33
Control Setup	35
Program	38
PAL/NTSC Camera	40
CAM Default Set	41
Dome Reset	42
Controlling one camera then another	43
Physical installation of the dome	44
4 Channel alarm input activation & single channel alarm output	47
Technical Data Table	49
Appendix A: Lightning Proof and Surge Signal Proof	50
Appendix B: General Information – The Cleaning of Dome Cover	51

Please read this operation manual carefully
before installing and using this unit !!!!



Please read the following;

1. Please read the operation manual carefully before installing and operating the product.
2. The actual dome requires a 24v AC power supply. The rated input voltage of the camera is 12V!!!! This gets its power from the dome and does not require a separate PSU. Do not connect 24V AC to the camera under any circumstances!!
3. During the course of transportation, storage and installation, the product should be handled with care avoiding vibration and any weight pressure, which may cause damage to the sophisticated optical and electronic equipment inside the machine.
4. Do not attempt to disassemble the camera. In order to prevent electric shock, do not remove screws or covers. There are no user-serviceable parts inside the camera.
5. Always use and stick to current electrical safety standards to install and use the dome. Use a correctly rated power supply. The RS-485 and video signal cables should be kept way from other high voltage equipment such as mains cables and especially fluorescent lights. Using an anti surge protection device is recommended to prevent damage to the domes from lightning and mains surges. Damage to domes by lightning or mains voltage surges is not covered under the domes warranty.
6. Do not operate in areas exceeding the stipulated limitations concerning temperature, humidity and power supply.
7. Do not aim the camera directly towards the sun or an extreme light source whether it is switched on or not. Do not let the camera focus on bright and stationery objects for a long time. Doing either of these may damage the camera.
8. Do not use strong detergents to clean the main body of the camera as these may damage the dome cover or paintwork. Wipe dirt with dry cloth. If needed a *mild* detergent can be used.
9. Operate the dome camera with great care to avoid shock or vibration. If operated incorrectly, the Dome could be damaged.
10. Ensure the dome is not dropped. Never mount the unit on a ceiling that cannot support its weight.
11. If necessary, use a commercial lens cleaning paper to clear the lens windows. Gently wipe the lens window until clean.

KEY FUNCTIONS

The excelPTZ dome range –

II. Description of Functions

This intelligent dome camera is a hi-tech CCTV product, which incorporates a high-clarity colour camera. It has a panoramic variable speed PAN/TILT movement, a multifunctional decoder, a character generator and an on-board processor for logic handling. The dome is easy to connect, install, maintain and operate, and has many features. The dome is compact and has a strong structure with a modern and appealing appearance.

1. Integrated Multi-Protocol Decoder

- a. The integrated multifunctional decoder can communicate with 16 different protocols. The baud rate can be independently set allowing compatibility with numerous systems with selectable baud rates from 2400 bps to 9200 bps. Dip switches control the selection of the protocol and baud rate thus making this dome camera easy to set up and use.
- b. This dome uses RS485 serial control and can address from 1 to 1023 cameras using binary addresses.







2. Integrated Speed-Variable PAN/TILT

- a. The dome can turn 360° horizontally and continuously with unlimited positions with an adjustable speed from 0.2 - 300rad/s and turning 0 - 90° vertically with a speed up to 120 rad/s.
- b. The dome can run at low speed, low noise, and does not show any picture shake.
- c. The dome has an automatic 180° flip facility and provides panoramic monitoring without any blind spots.
- d. This dome is a high precision unit and maintains preset positions up to $\pm 0.1^\circ$.

3. High Intelligent Settings

- a. This dome can store up to 128 preset positions in non-volatile memory that are not lost with a power failure. Refer to the section “Presets and other functions.”
- b. The dome can scan horizontally between two points and the scan speed can be modified. The dome can scan a range larger or smaller than 180° between any two points with adjustable speed settings. Refer to the section on “Auto Scan.”
- c. Six sets of tours (patrols) each with 16 preset positions can be programmed. The running speed and the dwell times are adjustable. Refer to the section on “Patrols (Tours).”
- d. The dome camera can simulate a route operated by you within a 40 second interval by utilising the Record Pattern facility. Refer to the section on “Record Pattern.”
- e. The logical structure of the menu makes all setups and programming of the dome camera more convenient and easy to operate.
- f. Proportional pan function. The dome travel speed will depend upon the extent of the zoom coverage. In telephoto zoom mode, the pan and tilt speeds will be slower for a given amount of joystick movement than that in wide zoom mode. This keeps the image from moving too fast on the monitor when there is a large amount of zoom coverage. This slowing down does not occur when going to a preset, but does occur in turbo mode when the high speed zoom is selected. The minimum pan and tilt speeds are 0.1 degree per second at full zoom.

4. Functions of the Camera (icons can be displayed on the screen when the OSD option of the camera is ON)

- a. **Focus Control Mode:** the user can adjust the focus of the camera manually. When the camera is in the near focus state, the icon  appears on the screen; when in the nearest state, the icon  appears and when in the far focus state, the icon  appears.
- b. **Backlight Compensation:** When the object to be shot is dark and looks dim, the user can increase the backlight compensation accordingly and the icon  appears on the screen.
- c. **White Balance:** If the image has incorrect colours displayed on the monitor, the user can use different modes to alter the white balance. There are 6 modes for selection: ① Indoor Mode  ② Outdoor Mode  ③ Touch Mode  ④ Automatic Trace of White Balance ATW ⑤ Manual WB-MAN and ⑥ Automatic Mode.
- d. **ZOOM Control:** The user can control the lens according to actual conditions, and the symbol $^w \left[\blacksquare \square \right] ^T$ appears on the screen. The left section refers to the optical multiplication whilst the right section refers to the digital multiplication.
- e. **Electronic Shutter:** The electronic shutter is fixed on 1/50 second after initialisation when the camera is switched on, and the digits 50 appear on the screen.
- f. **Setup of Image Effect:** The camera works in the OFF state under normal conditions and a no image effect symbol appears on the screen. When “B&W” appears on the screen, it means that the camera is in black and white mode.
- g. **AE Mode:** The setup of Manual/Automatic mode.

5. Special Dome Features

4 channel alarm input activation & single channel alarm output

One of the special features of this dome is that it has four in-built alarm channels to call four independent presets. This means that for example you may have a door contact and when the contact is closed, it sends a 0 volt alarm switch to the dome on one of the four alarm channels. The dome will then call a previously set preset position and lock the camera onto that position. A single channel alarm out, allows the connection of an audible alarm, lighting or other warning device. When more than one alarm input channel is utilised and activated, the dome will switch to the next channel after two seconds. However once an alarm input channel has been activated, the dome will remain locked to the preset position/s and will not resume a patrol, auto scan or a record pattern until the alarm condition is cleared. However the HOME Option in the dome menu can be set to restart a tour if necessary. The following alarm channels call the preset positions detailed:

Alarm channel 1 when activated calls preset number 29

Alarm channel 2 when activated calls preset number 30

Alarm channel 3 when activated calls preset number 31

Alarm channel 4 when activated calls preset number 32.

Refer to the instructions under “Physical installation of the dome” for the wiring diagram.

Getting the dome up and running!



You **MUST** connect up the dome and your control equipment on a workbench or kitchen table before the actual site installation and **CHECK YOU KNOW HOW TO INSTALL IT CORRECTLY!!!!!!!!!!!!!!!!!!!!!!**.

By doing this you can set-up any DIP switches, adjust the camera, and learn about how it operates before taking it to site. This will save you hours of time on-site trying to work out why a particular item doesn't function as you expected it to. There is nothing worse than installing something and then having to take it down to see how to get it working!! Do the learning curve in the comfort of your own premises!!!!

Do you KNOW how to install PTZ equipment that is controlled by RS485 data signals?

If not please read the following introduction to PTZ >>>....

Overview- introduction to fitting PTZ equipment

Generally speaking, PTZ Domes requires four things;

- 1- They require a power supply and a cable to supply this power to the dome. Often, external domes are 24V A.C but some mini pan and tilt domes are 12V.
- 2- They require a cable to get the video signal back to the monitor or recording device.
- 3- They require a cable to transmit the "RS485 control signal" from the keypad or DVR to tell the dome to pan, tilt and zoom etc.
- 4- They require something to control them, either a keypad or a DVR.

The following diagram indicates the basic cable requirements for a PTZ system.

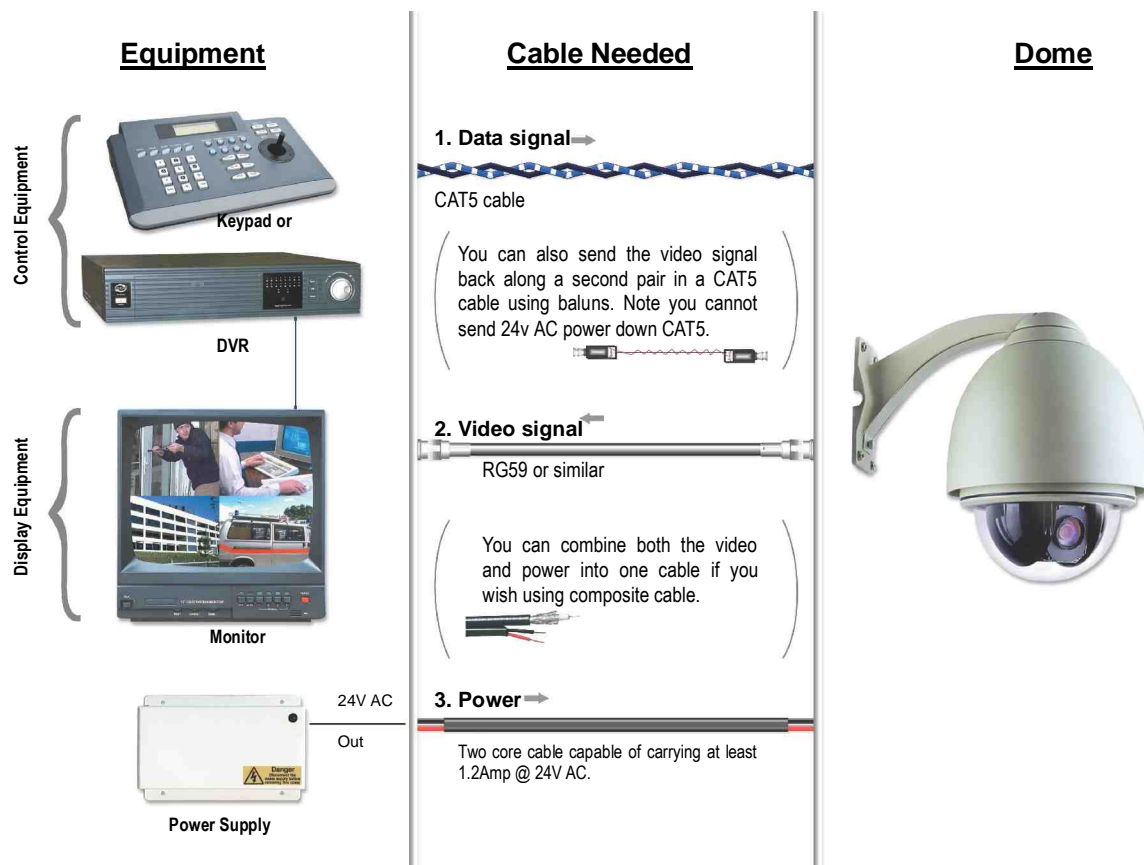

You can get “composite” cables that will carry both the power and the video signals and this has the benefit of combining two of the three cables into one. You may choose to power the dome locally to it, so you may only need to get the video signal back from the dome and the RS485 control signals to it. If this is the case you may choose to use a pair of BALUNS. By using baluns you can send the video signal and control signal down the same CAT5 cable just using different cores for each signal.

The control signal (RS485) is nearly always sent along a “twisted-pair” type cable. The twists in the cable help prevent interference affecting the data signal by “shielding” it. Many installation companies use a CAT5 type or similar cable to run out to the domes to carry the data signal.

If you are considering using baluns please note - DVR’s tend to require very good video signals to function correctly and “passive baluns” can loose some signal strength over the 50 meter mark so try to restrict the use of passive baluns to below 50 meter cable runs when using them with DVRs. Above this distance perhaps consider an active balun. Active baluns require power, passive baluns do not.

You can mix and match how you wire up your PTZ installation and the following general diagram gives you a guideline about how to do it. Remember this is a GUIDE and is not an instruction what to fit!

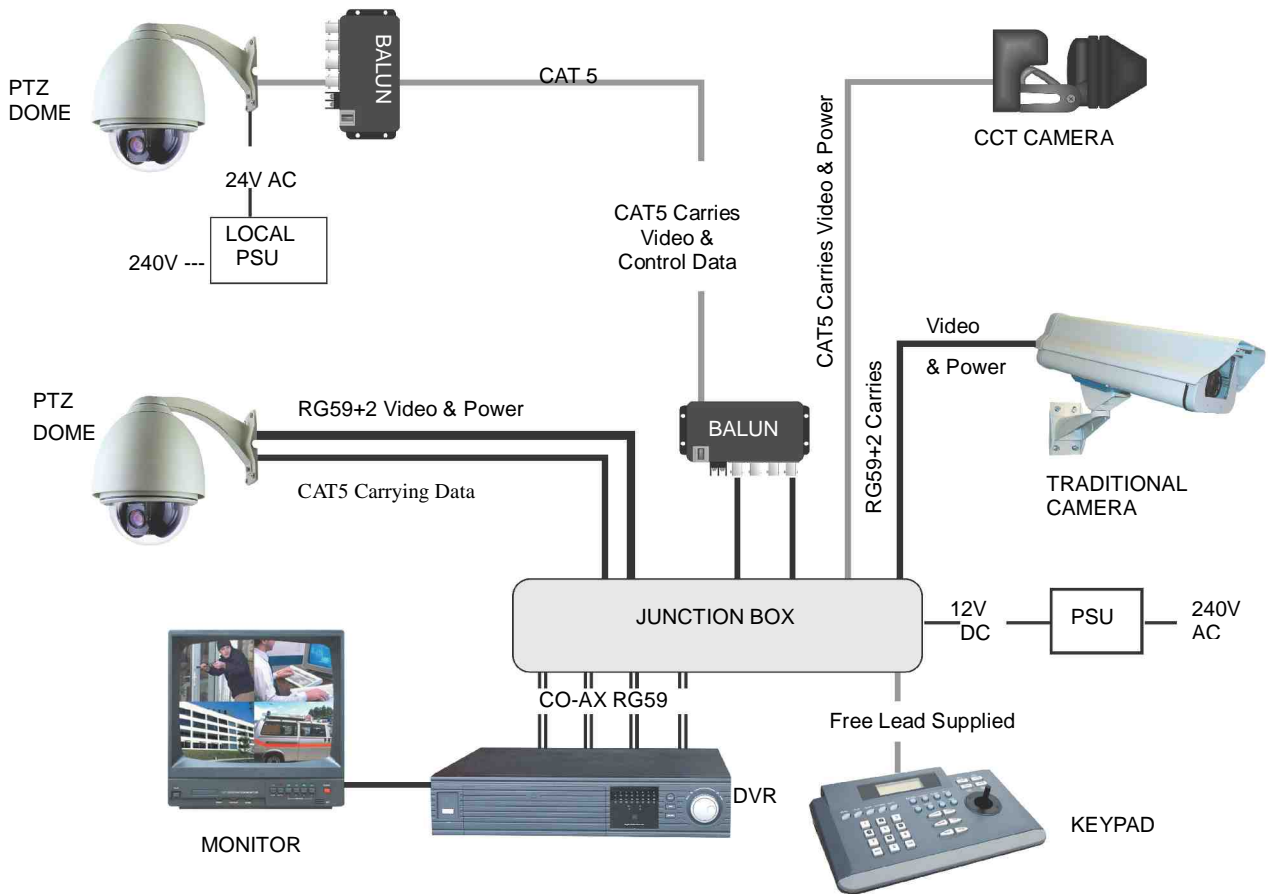

Many installation companies can get the power and video signal correct, but struggle with the control of the dome using the keypad or DVR using the RS485 data.

The key to successfully installing the data cabling to the dome is to get the basics right. Use a quality data cable such as CAT5 (never use just a standard untwisted cable such as alarm cable for the RS485 signal).

Also, you must follow the RS485 wiring convention; the following section explains this;

RS485 Wiring methods & Tips >>>>>

1. Characteristics of RS485

As specified by RS485 standards, RS485 is a half-duplex data transmission type with characteristic impedance of 120Ω . The maximum load capacity is 32 units (domes, keyboards and DVRs).

2. Transmission distances of RS485 Signals using CAT5 or similar cables

Selecting a CAT5 or similar sized twisted pair data transmission cable, the maximum theoretical transmitting distances are as follows:

Baud Rate	<u>Maximum</u> Transmitting Distance
2400 Bps (PELCO-D)	1500m
4800 bps	1000m
9600 bps	600m

PLEASE NOTE - Using inferior cables, or installing the dome in an environment with strong electromagnetic interference, or connecting a lot of PTZ domes to the same cable carrying the RS485 signal will reduce the maximum transmitting distance.

3. RS485 Connection methods

METHOD 1 – DAISY CHAIN CONNECTION.

The general RS485 standard recommends a “daisy chain” connection of equipment that is to be controlled. This means that the control cable is looped out of the one dome to the next dome and so on. The last dome in the line is then fitted with what is known as a “termination resistor”. This has a value of $120\ \Omega$.

The resistor is built in the PTZ domes and is activated by moving the appropriate “jumper” in the dome. The keyboard itself generally has a built-in $120\ \Omega$ resistor. These termination resistors help make the signal more stable and give the system better reliability so the domes function as expected. A common mistake installer’s make is not making sure the $120\ \Omega$ resistor is switched ON in the LAST dome. Also installers often select the resistor to ON in another dome in the chain, these errors will make control of the dome unpredictable.

A simplified Daisy chain is shown below;

This first diagram shows the cables looping in one dome and out of another;

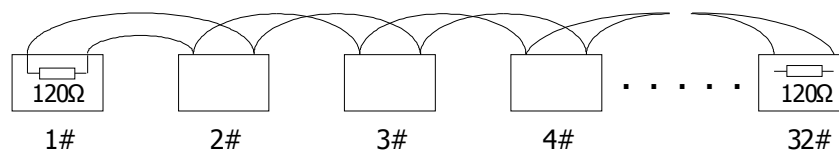

Standard Daisy-Chain connection for the RS485 PTZ control signal

(just the last dome only has the $120\ \Omega$ resistor set to on, the first device is the keyboard and has the $120\ \Omega$ built in as default)

This next diagram is a slight variation on the Daisy Chain arrangement. Again it’s one cable going out to all the domes but instead of the cable going into each dome then back out to the next one, a junction box is used to “Spur-Off” to each dome. Whilst this can be done THE SPUR LENGTH (D) must be NO MORE THAN 10 meters!!!!!!!!!!!!!! The overall cable length between the Controller and the last dome is limited to around 300 meters in such an arrangement.

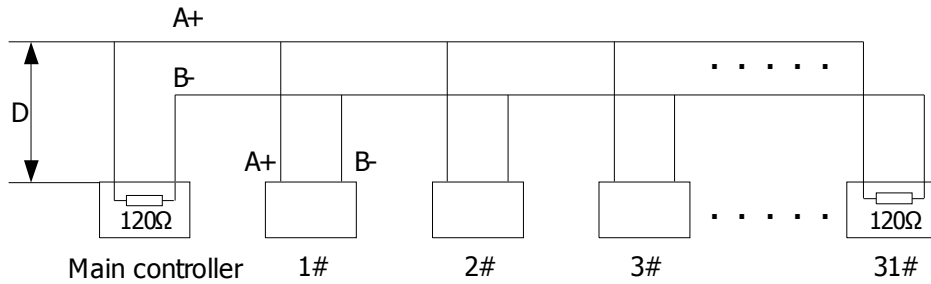

Daisy-Chain connection WITH SHORT SPURS for the RS485 PTZ control signal

(one main radial with very short spurs to each dome off it, keeping the spurs to less than 10 meters)

TIP - The connection of a 120 Ω termination resistor: The termination resistor is ready fitted on the domes pcb, all you have to do set it is move the jumper from Pins 2 &3 to pins 1 & 2.

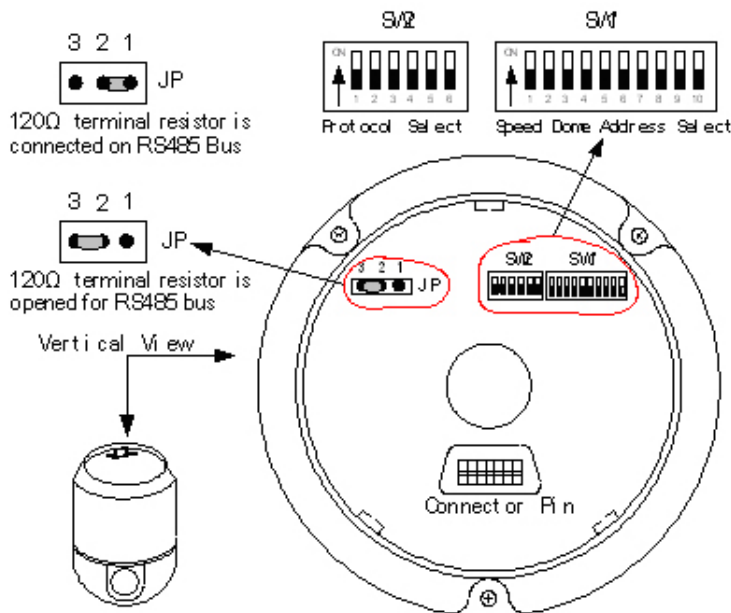

STAR method of connection.

In some circumstances you may need to adopt a star configuration for practical purposes. For instance, all the domes may be so scattered on a large site that running out separate spurs to each dome in a “STAR” array is the only practical solution.

So how do you do this in practice?

The termination resistors must be connected to the two domes that are farthest away from each other, such as domes 3 and 5 in the following “Star diagram”. Note that all the other domes do not have the 120ohm resistor connected. The resistors are already fitted to the domes PCB but by default are not in circuit. To put them in circuit you must move the small “jumper” as previously indicated.

As the star configuration is not in conformity with the requirements of RS485 standards, problems such as signal reflections may arise, especially when there are long cable connections. The results are that control signals are decreased and the dome may not respond to, or just responds intermittently to the controller.

If your STAR circuit is not too extensive with each spur in the region of 20-50 meters you can expect quite good reliable performance using this technique. If you experience any problems though, there is a RS485 distribution box available CODE PT750 to help overcome any problems.

The Star circuit for wiring PTZ's.

The two furthest domes need the 120ohm resistors enabling, by moving the "Jumper" In this example it's domes 3 &5.

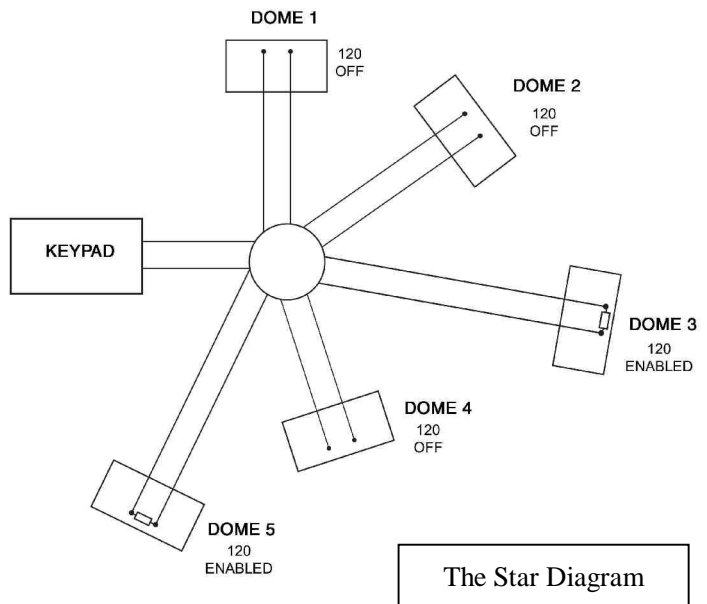

Overcoming RS485 data loss using an RS485 distributor

In the real world not everything always works exactly as it's expected to!

RS485 data signals that control the domes' movements are tiny signals that can get corrupted for many reasons. Poor cable quality, not using a PAIR of cores from a CAT5 but using one core from TWO separate pairs, running the CAT5 cable near mains equipment such as florescent lighting all will have a detrimental effect on the signal. These are things that you can correct with good installation practices.

Where you wish to run several separate CAT5 cables out to send the RS485 data signal out to the domes you are in effect correcting the STAR method of RS485 data distribution. As previously mentioned the problem with the Star method is that it is not actually designed for RS485 but generally works okay if you follow the previous notes on getting the 120ohm resistor setting right, as per the previous notes.

One way that takes the guesswork out of installing the Star method is to utilise an RS485 distributor. This has the advantage that the RS485 signal is correctly distributed to the domes so that they behave as expected. You can create up to 4 spurs to the domes and put up to 4 domes on each spur. Just like the Daisy chain method the end dome on each spur needs to have the 120ohm resistor enabled.

Although the RS485 distributor is a small additional expense, it takes some of the guess work out of the installation design and gives a more flexible approach to cabling which itself can save time and money on

the installation. Not forgetting you get more predictable results!

The RS485 distributor (PTZ750) amplifies the RS485 control signal and distributes it evenly to 4 separate spurs, each spur can have up to 4 domes. This means that you could theoretically have up to 4 individual spurs of over 1000mtrs each to control up to 16 PTZ domes in total.

Ideally you would put just one dome on each spur from the PTZ750 but up to 4 domes is generally acceptable. The following diagram shows a typical use of the PTZ750 RS485 distributor.

In the following example and diagram, domes 1,4,5 and 7 are at the end of each spur and therefore require the 120ohm resistor enabling by moving the jumper setting within the domes. Domes 2,3 and 6 are all “midway” in each spur and do not need the 120ohm resistor and can be left as default. The PTZ750 itself has four 120ohm resistors built in as shown and you do not have to do anything with the PTZ750 as the resistors are permanently connected within it.

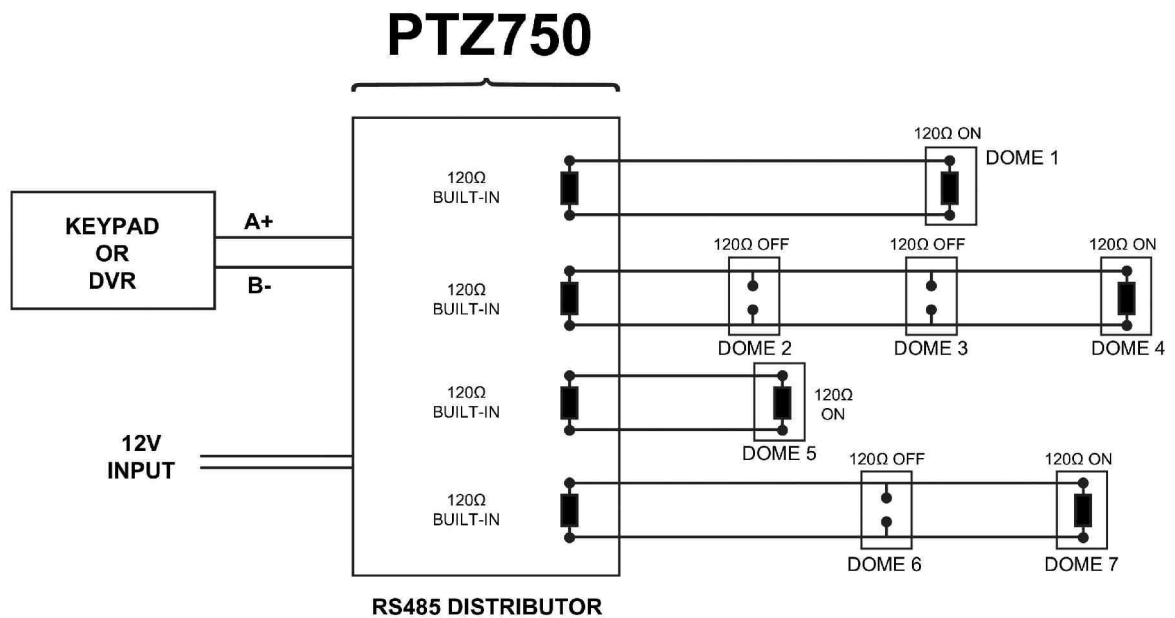

Diagram showing how to use an RS485 distributor to improve PTZ control reliability)

Please note if you have the PTZ750 located within 5mtrs of the keypad or DVR you can connect up to 3 of them in parallel.

Setting up the Dome Camera

1. Connection of the System

There are many ways to wire up a PTZ system.

If you have read the introduction at the beginning of these instructions you should have got a good idea what your options are.

Below is a general schematic diagram showing you some of these options.

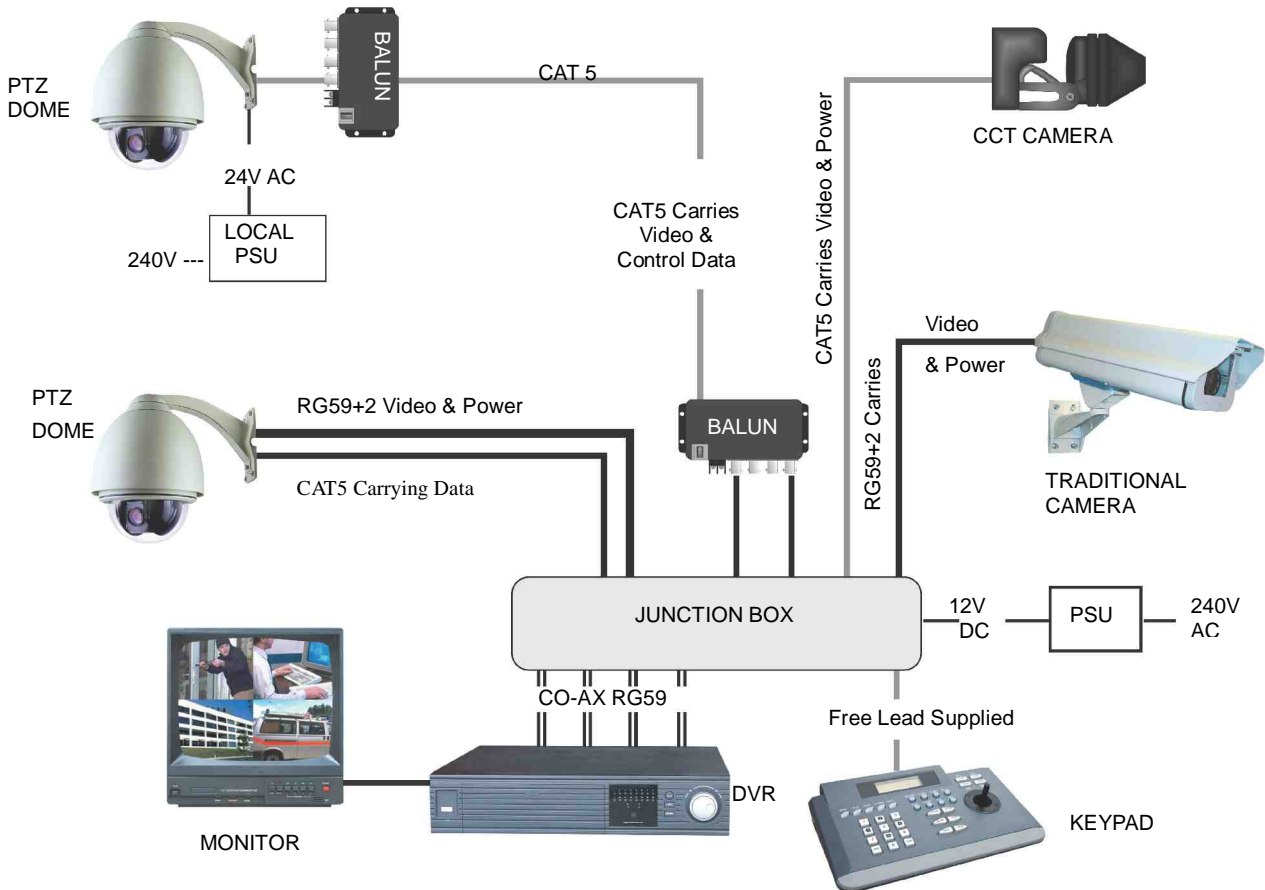

Figure 1.

Powering the domes-

All the domes will need power. For this dome it is a 24V A.C power supply. The power supply must be capable of delivering at least 1.25A per dome.

You can either power each dome with its own PSU locally to it or have the PSU's remotely situated perhaps near the keyboard or DVR. The domes require a current of about 1.25A when the heater is on and you must take this in to consideration when working out maximum cable runs.

Please note - The domes heater doesn't come on until it senses the temperature drops below 0 degrees Celsius. At this point the dome will need up to 1.25A @ 24V A.C to operate. Please make sure that you have a sufficient power supply and cable installed to cope with this. Obviously the dome may work okay in the summer but when winter kicks in and the dome's current draw jumps from 400ma to 1.25A, an inadequate

power supply or a cable with too much voltage drop may stop the dome from working properly. When winter comes don't be suddenly caught off guard when your customer rings you to say the dome has suddenly packed in because it's gone cold!!

A popular way to power the domes is using our COMPOSITE VIDEO cable (or the shotgun as its also known) as this cable can carry the power to the dome and video signal back to the monitor or DVR.



(or the

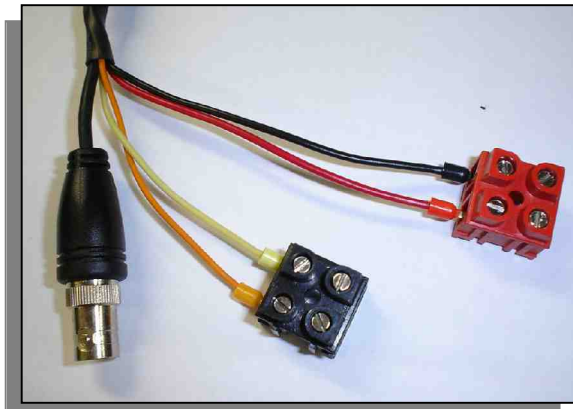

The power connection

The RED & BLACK cable coming out of the dome connected to the RED terminal block are for power. Connect a suitable 24V A.C power supply to this pair of cores.

The BNC connector is the "VIDEO-OUT" from the camera and goes to the monitor or "VIDEO-IN" of a DVR camera input.

The Orange and Yellow pair of cores that go in to the BLACK terminal block are the data cables. These are the cores that carry the RS485 control signal to the dome from either the keyboard or the DVR. The next section of the instructions gives more detail on how to connect the RS485 data. Please also read the RS485 WIRING METHODS & TIPS section towards the beginning of these instructions.

The following table gives you an indication of the maximum lengths that you can achieve using this cable the composite cable and the PTZ400 range domes.

Power cable requirement – Assuming a starting voltage of 24V A.C is applied at the PSU end.

Composite cable	Heater OFF	Heater ON
Maximum run	80mtr	70mtr

The distances are relatively short due to the high load of the dome when it starts up. If the voltage of the dome drops below around 20V A.C it will fail to initialize. Obviously you can power the domes locally if you wish.

RS485 connection - *Connecting the Keypad or DVR to the Dome.*



The dome is controlled by an RS485 data signal that is given by either a KEYPAD or a suitable DVR. This data signal tells the dome to pan, tilt, zoom etc. Its important that you read the early section of these instructions to understand the fundamental principle of RS485 cabling techniques so that you get it right.

RS485 has two cores, A and B or sometimes known as RS485 + (A) and RS485 – (B) if you get these two the wrong way around then you will not be able to control the dome. Sometimes installers get the connections right on one dome but not on the other and find only one dome works. They then swap the wires around at the keyboard only to find out one dome has now burst in to life and the other one now failed!! But they don't put 2 + 2 together and realize their mistake that they have wired one dome different to the other. Take great care getting these the right way around and make sure you wire each dome IDENTICALLY so

that if you have to swap the A & B lines over at the keyboard you know all domes are wired the same!!

The PTZ400 series adopts the following RS485 convention;

ORANGE = RS485 + or A

YELLOW = RS485 – or B

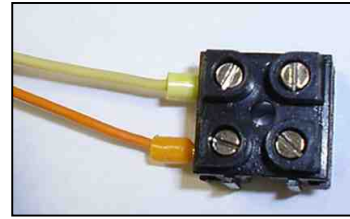

You should initially be wiring the dome to the keyboard or DVR on your workshop bench or at least your kitchen table to prove you know how to get everything to work. Once you have done this, it is just a job of extending the cables and physically installing the domes on site. You must obviously take note of the RS485 wiring techniques mentioned at the beginning of these instructions and get the 120ohm resistors correct in the “End of line” domes. Generally speaking you will always be extending the RS485 signal from either the keypad or the dome using a CAT5 or similar cable.

The Keyboard models type CCT786 & CCT768 are supplied with a connecting lead and a break out box that looks like the following picture.



The RJ45 lead supplied with the keyboard connects into the rear of the keyboard into the slot marked “OUT” do not connect it to the “IN” position mistake.

by



This lead provides the RS485 A and RS485 B connections from the keyboard. It is this cable that you would extend using 1 pair of conductors from a CAT5 cable. To test the dome on your workbench you can obviously omit the “extension” cable as the dome and keyboard are next to each other.

Now connect the RS485 data cable to the breakout box. Note that the orange connection is the RS485 + A Line connection and the yellow is the RS485 – B Line connection. The following picture shows the breakout box with the actual dome connected straight to it. The orange of the dome connects with the orange of the breakout box and the yellow of the dome connects with the white of the breakout box.

YELLOW

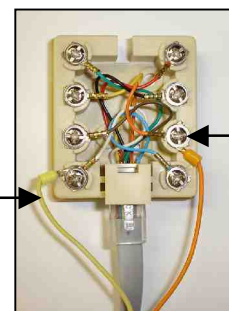

ORANGE

Obviously if the dome was on site you could not connect it to the breakout box directly. This is where you would use the CAT5 cable to connect the two together. You could use any pair out of the CAT5 cable but they must be two cores from the same pair. Why not use for example the orange pair so that the colours tie together a little? If you use cores from two different pairs in the CAT5 cable you will not get the benefit of the shielding effect of the cable twists and the dome will function erratically. You must always use a core from a PAIR, not two cores from two different pairs!!

Connecting the video out of the dome.

The dome has a short BNC lead attached to it, this is the lead that carries the video signal from the built-in camera. You need to extend this lead to the “VIDEO-IN” of the DVR or monitor. Use a good quality RG59 coax cable or similar to do this.

TIP – If you can’t get a picture at the remote end you could always take your test monitor to your PTZ dome and check the picture quality on its own short BNC lead.

If you’re testing the equipment on a workbench you now have a one dome system.

For setting up the keyboard and testing the dome please read sections on default Dome settings and using the keyboard.

You can use a keyboard or a suitable DVR to control the dome. A suitable DVR would be one with PTZ functionality built into it and preferably Pelco-D protocol. If your DVR has a list of protocols it’s always best to try “JEC” first or “Pelco-D” protocol, as these are very widely available. In the DVR, with either JEC or Pelco-D set, you must also make sure you set up the “baud-rate” to 2400. JEC protocol is very similar to Pelco-D but has a wider tolerance.

A typical site installation would look like the following diagram on the next page.

It shows the dome connected to the keypad plus how the dome could also be connected to a DVR instead of the keypad or at the same time. DVR’s that have the capabilities of PTZ control will have a terminal or connection on them somewhere, where the dome’s RS485- A and RS485- B line can connect to. Please refer to the individual DVR instructions of how to do this.

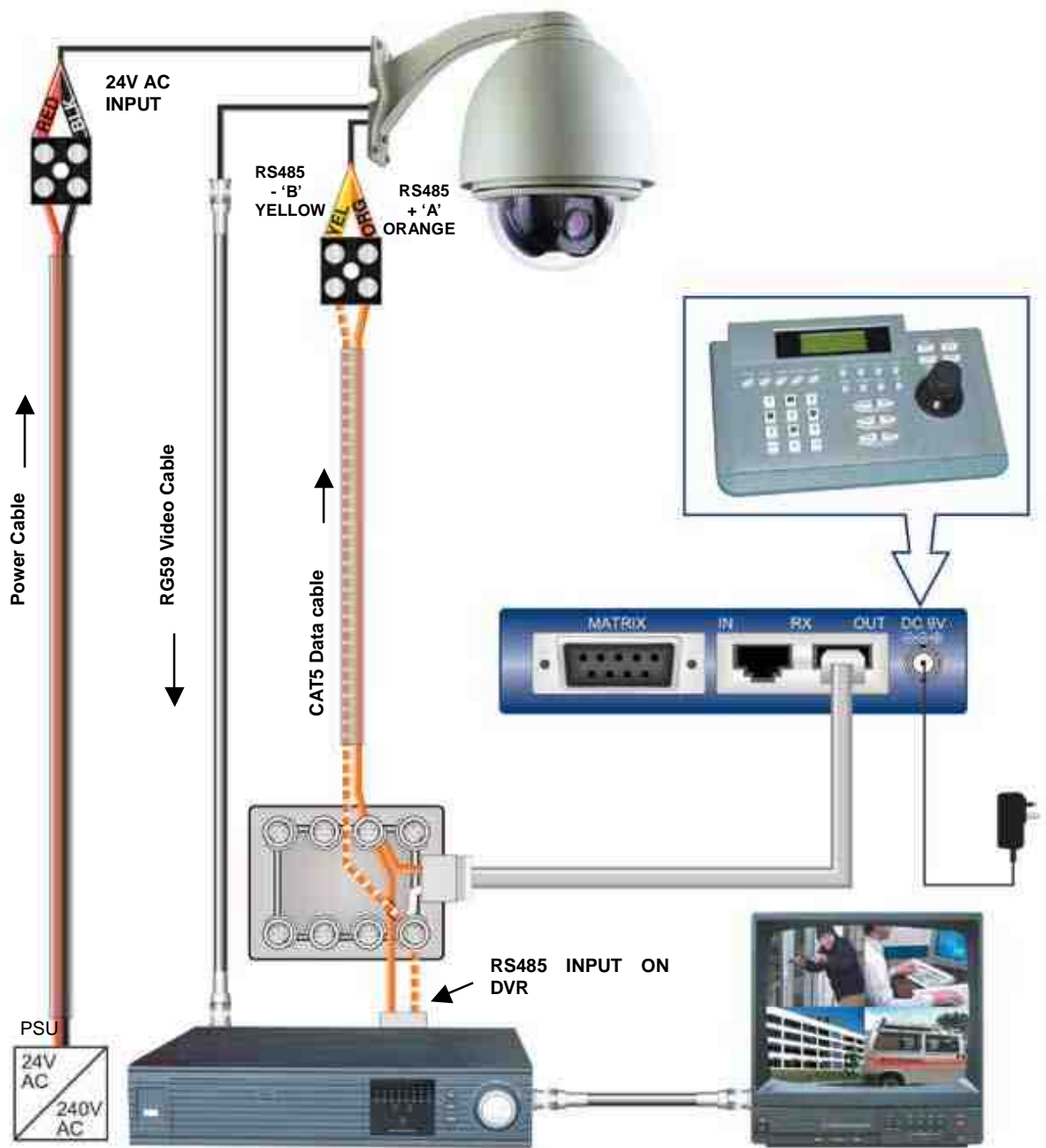

If you're using more than one dome on a site

Each dome has a unique “address” so that if you are using more than one on a site the keyboard “talks” to the right dome when you want it to PTZ. If you only have the one dome on the site then the default “address” of “1” is okay and you have no reason to change the dome from this.

With multiple dome sites you need to set up each dome address separately.

The following diagram shows the switch options.

SW2 sets up the protocol. This switch is dealt with later in these instructions.

For most System Q equipment they should always be set to PELCO-D 2400 baud rate. In the diagram this is correct. The Jumper on the far right either enables or disables the 120ohm resistor.

Setting up a unique ADDRESS

in a dome –

SW1 is used to set address of the dome camera from 1 – 1023.

To set the dome address at 1 put switch 1 up.
 To set the dome at address 2 put switch 2 up
 To set the dome at address 3 put switches 1
 2 up.
 ..and so on..

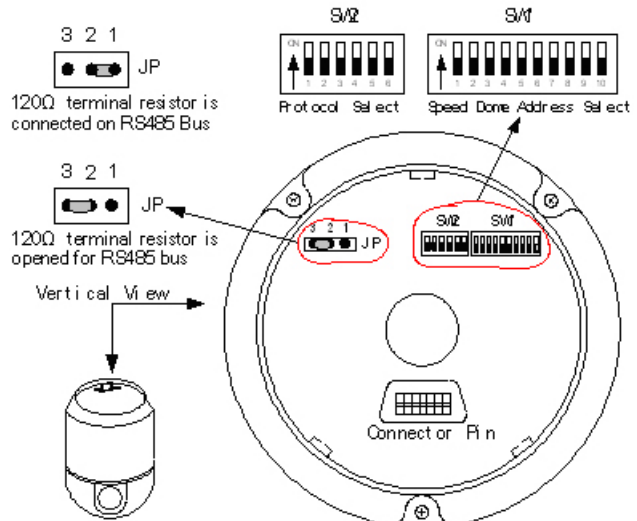

The following table indicates how this is done.

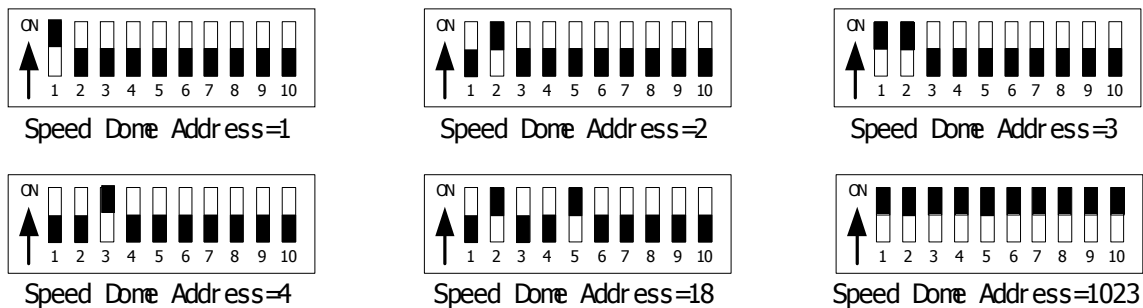

Dome Address	ID-CODE Status									
	DIP-1	DIP-2	DIP-3	DIP-4	DIP-5	DIP-6	DIP-7	DIP-8	DIP-9	DIP-10
1	ON	OFF	OFF	OFF	OFF	OFF	OFF	OFF	OFF	OFF
2	OFF	ON	OFF	OFF	OFF	OFF	OFF	OFF	OFF	OFF
3	ON	ON	OFF	OFF	OFF	OFF	OFF	OFF	OFF	OFF
4	OFF	OFF	ON	OFF	OFF	OFF	OFF	OFF	OFF	OFF
5	ON	OFF	ON	OFF	OFF	OFF	OFF	OFF	OFF	OFF
6	OFF	ON	ON	OFF	OFF	OFF	OFF	OFF	OFF	OFF
7	ON	ON	ON	OFF	OFF	OFF	OFF	OFF	OFF	OFF
8	OFF	OFF	OFF	ON	OFF	OFF	OFF	OFF	OFF	OFF
9	ON	OFF	OFF	ON	OFF	OFF	OFF	OFF	OFF	OFF
10	OFF	ON	OFF	ON	OFF	OFF	OFF	OFF	OFF	OFF
11	ON	ON	OFF	ON	OFF	OFF	OFF	OFF	OFF	OFF
12	OFF	OFF	ON	ON	OFF	OFF	OFF	OFF	OFF	OFF
13	ON	OFF	ON	ON	OFF	OFF	OFF	OFF	OFF	OFF
14	OFF	ON	ON	ON	OFF	OFF	OFF	OFF	OFF	OFF
15	ON	ON	ON	ON	OFF	OFF	OFF	OFF	OFF	OFF
16	OFF	OFF	OFF	OFF	ON	OFF	OFF	OFF	OFF	OFF
17	ON	OFF	OFF	OFF	ON	OFF	OFF	OFF	OFF	OFF
18	OFF	ON	OFF	OFF	ON	OFF	OFF	OFF	OFF	OFF
...
1023	ON	ON	ON	ON	ON	ON	ON	ON	ON	ON

Table 1

2. Setup of the Protocol and the Default Baud Rate.

As shown in Table 2, SW2 is used to set the protocol of communication and the baud rate used by the dome camera. DIP-4 to DIP-1 of SW2 is used to select protocols and a maximum of 16 different protocols can be selected. The following table shows states of coding switches of protocols selected by the dome camera in which ● means the protocol has been integrated while ○ means the protocol is under development.

Pelco-D 2400 is used for most System Q equipment.



Protocols	DIP status				Normal Baud Rate	
	DIP-1	DIP-2	DIP-3	DIP-4	DIP-5	DIP-6
SAMSUNG	ON	OFF	OFF	OFF	OFF	ON
B01	ON	OFF	OFF	OFF	OFF	ON
NEON	ON	OFF	OFF	OFF	OFF	ON
Santachi	OFF	ON	OFF	OFF	OFF	ON
PELCO-D	ON	ON	OFF	OFF	OFF	OFF
PELCO-P/4800	OFF	OFF	ON	OFF	ON	OFF
PELCO-P/9600					OFF	ON
PANASONIC	ON	OFF	ON	OFF	OFF	ON
Longcomity	OFF	ON	ON	OFF	OFF	ON
HUNDA600	ON	ON	ON	OFF	OFF	ON
LILIN	OFF	OFF	OFF	ON	OFF	ON
VICON	ON	OFF	OFF	ON	ON	OFF
MOLYNX	OFF	ON	OFF	ON	OFF	ON
KALATEL	ON	ON	OFF	ON	ON	OFF
VCL	OFF	OFF	ON	ON	OFF	ON
Reserved	ON	OFF	ON	ON	OFF	ON
ALEC	OFF	ON	ON	ON	OFF	ON
Ultrak	ON	ON	ON	ON	OFF	ON

Some protocols and the states of the coding switches of normal baud rates of these protocols are shown as follows:

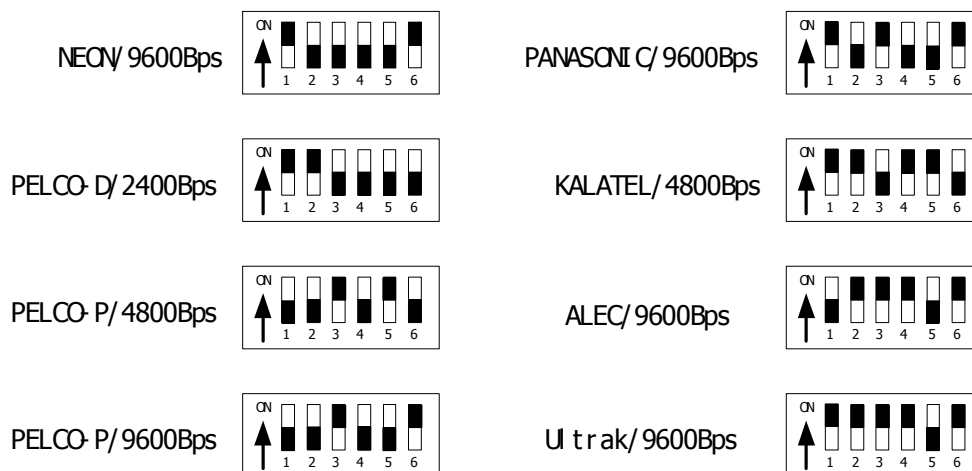

Setup of the Baud Rate of Communication.

As shown in Figure 2, SW2 is used to set the protocol of communication and the baud rate used by the dome camera. DIP-6 and DIP-5 of SW2 are used to select the baud rate of communication and 4 different baud rates can be selected in maximum. If the controller adopts a non-standard baud rate, you can adjust it to be identical with that of the controller, as per the following table.

Baud Rate of Communication	DIP-1	DIP-2	DIP-3	DIP-4	Setup of Baud Rate	
					DIP-5	DIP-6
2400bps					OFF	OFF
4800bps					ON	OFF
9600bps					OFF	ON
19200bps					ON	ON

Using the CCT786 and CCT768 keyboard with the excelPTZ series



NOTE: For MINI 2D Keyboard type PTZ700 please refer to the instructions supplied with the actual PTZ700 keyboard.

The CCT768 & CCT786 keyboards require a 12V PSU (350ma) that is usually the plug in type. When you first take the keyboard out of the box you will need to set it up for the domes that you are using.

The dome you have purchased has the default settings of; PELCO-D 2400-BAUD rate Address 1

If you look at the image of the LCD display below you can see the CAM=001 indicates that the keyboard is ready to talk to camera with address 1, if you have another dome set at camera address 2, press 2 followed by CAM. This would change the screen to CAM=002.

If you have multiple domes you will need to change the address of each dome so they are different but PLEASE LEAVE THE DOMES ON PELCO-D 2400 BAUD RATE.

There is an LCD display on the keypad.

When power is connected this will display something like the following: >>>

The current protocol (protocol D or P)

The current camera address (each P/T device requires a unique address 1-32)

The current baud rate



LCD of keypad CCT786 & CCT768 with correct default setting for this dome at address 1

To set up the keyboard to the correct settings for this dome do the following;

KEY SETTINGS FOR THE DOME – ENTER THESE into the keyboard type CCT768 & CCT786

For **2400-BAUD rate**: Input 24 and press the PRG key (default dome setting)

To select **PROTOCOL D**: enter 44 and press the PGM key (default dome setting)

To select **CAMERA ADDRESS 1** press 1 and then press the CAM key (default dome setting)

TIP - For advanced uses the keyboard also can also adopt the following features (these settings are not used for this dome!!!)

These parameters can all be changed in the following manner:

To select **PROTOCOL P**: enter 50 and press the PGM key

For **1200-BAUD rate**: Input 12 and press the PRG key

For **4800-BAUD rate**: Input 48 and press the PRG key

For **9600-BAUD rate**: Input 96 and press the PRG key

PRESETS and other functions.

The dome has up to 128 presets that once programmed with stay in the domes non-volatile memory so they will be retained even after a power cut.

What is a preset? A preset is a particular area or object that the dome was looking at and has been stored into its memory so when the preset is “called-up” the dome will select the area again without the operator using the joystick to do this. Even the zoom at the time is stored into the preset. This means that you could for example store a PRESET of a car-park entrance. When the operator calls up this preset the camera automatically zooms in on this area. By storing more than one preset you can add even more functionality to the dome. By having two presets, you can then get the dome to “SCAN” between the two locations. You can even vary the speed of this scan.

Having 3 or more presets you can get the dome to go on a TOUR (PATROL) of the presets. When you run the patrol the dome goes to one preset, then waits a short period then on to the next preset and so on. The dome continues to cycle around this patrol until you cancel it. The length of time the camera stays at one location and the speed of travel between each preset point can be set in the menu.

PRESETS -How to set up a preset

Aim the dome where you want it to look, zoom in or out to get the correct scene and let the camera auto focus. Now press the following keys on the keypad : **xx PRESET** (where **xx** is the preset number you wish to store). For example **01 PRESET** would store **PRESET 01** and the camera would always go to this location when **01** is “CALLED”.

To test if the preset is stored correctly use the joystick to move the camera to point in a new location. Now press **xx CALL** (where **xx** is the preset you wish the camera to go to). In this example if you press **01 CALL** the dome should go straight to the PRESET 01 location.

TIP -You may wish to write down a list of presets that you have stored next to the keypad for the operator.

CALLING a preset

This may be as follows;

PRESET 01 = MAIN GATE (a long zoom shot)

PRESET 02 = ENTRANCE DOOR

PRESET 03 = FIRE ESCAPE

PRESET 04 = EMERGENCY EXIT

PRESET 05 = CAR PARK (zoomed-out wide angle)

PRESET 06 = CAR PARK (zoomed-in narrow angle)

When the operator wishes to quickly zoom in on the MAIN GATE all he has to do is press **01 CALL**.

To go to the EMERGENCY EXIT he would press **04 CALL** and so on.

To call up any previously stored preset camera location, simply press **xx CALL**, where **xx** is the preset number.

Patrols (Tours) – How to set them up and use them

A patrol (tour) is simply a collection of at least three preset camera locations that are run in sequence with the dome stopping at each location for a brief period of time and then moving on to the next preset.

For example, you could use a patrol so that an outside dome camera points at a gate, then at a side doorway, then zooms out to get an overall shot of a car park and finally zooming in on a delivery bay, before repeating the whole cycle again. Patrols can be useful for both outside and internal PTZ's. For a shop they could be used to cover key areas like clothes rails, tills and changing rooms in a sequence.

To set up a patrol you need to set up the individual stop points where the camera will pause. These are called *presets*.

An example four preset mini-tour

Setting the presets using the keypad

STEP 1- Using the keypad joystick, move to where you wish to start the tour and then press **01 PRESET**

STEP 2- Now move to the next location and press **02 PRESET**

STEP 3- Now move to the third location and press **03 PRESET**

STEP 4- Finally move to where you wish to end the tour and press **04 PRESET**

Deleting a preset

You may wish to delete a preset.

To do this press **xx PRESET** holding the preset button down for 3 seconds at the end.
(xx = preset number).

As you are holding the preset button down for the 3 seconds you will see the preset number go to 000 on the keypad. This means that the preset has been deleted.

For example to delete preset 1; press **01 PRESET** (holding the preset button for 3 seconds)

Obviously if you wish to overwrite a preset with a new location, simply aim the camera at the new location and store the preset as normal, this will simply overwrite the old preset.

Setting the Patrol (Tour)

To setup the patrol/tour you need to enter the Advanced Menu System by selecting **95 CALL** on the keypad. You will see the **Main Menu** displayed on the screen.

Using the joystick up/down direction movement, select the **PROGRAM** menu.
Use the joystick pan right movement to enter this menu.

Now use the Joystick up/down direction movement to select **SET PATROL**. To the right of this, is the patrol sequence number. By moving the Joystick to the right this number can be increased from 1 ~ 6 (up to six patrols/tours can be programmed) or decreased using the left direction movement. Start with sequence **01**.

Now press the **OPEN** button to select edit mode. A table will be displayed showing 16 patrol item numbers. Note that the screen is divided into two halves with two patrol positions per line. Only the odd patrol item numbers are identified down the left hand side of the display. In the bottom left hand corner the patrol sequence number is displayed. This can be 01 ~ 06.

In the example we are setting four presets in the first patrol sequence.

To edit a patrol sequence

NO Patrol Item No.
POS No. of Preset Position
SP Dome speed (0, 1~8)
 0 and 1 are fastest speed –
 8 is slowest speed
TM Dwell time at this position
 Time 0 ~ 99 seconds

NO	POS	SP	TM	POS	SP	TM
01	001		01	01	002	01
01						
03	003	01	01	004	01	01
05	---	--	--	---	--	--
07	---	--	--	---	--	--
09	---	--	--	---	--	--
11	---	--	--	---	--	--
13	---	--	--	---	--	--
15	---	--	--	---	--	--
SEQ:01				CLOSE.EXIT		

SEQ:nn The Patrol number. (01 ~ 06)

Special Note: The patrol item number (**NO**) is an ascending number list of the preset items within this sequence. It may not necessarily reflect the actual preset number. You could for instance have preset item (NO) 01 with preset position 004 as the first preset required.

Enter the preset position number (**POS**), the dome speed (**SP**) and the dwell time (**TM**) for each preset by using the Joystick up/down movement. Move the Joystick to the right to move to the next field.

After including all the presets required in this patrol/tour, press the Keypad **CLOSE** button to exit. If you add extra presets later and wish to incorporate into a patrol/tour already created, you must add the additional preset positions in the necessary SET PATROL table sequence.

Now exit the menu by moving the Joystick down, selecting **EXIT** and then moving the Joystick to the right to return to the Main Menu. Again use the Joystick to select **EXIT** and exit the Advanced Menu System by selecting the right pan movement.

Calling the Patrol (Tour)

There are two methods of initiating the patrol or tour. If you enter **91 CALL** via the keypad you can initiate patrol/tour sequence 1 only.

You may also initiate a patrol or tour through the Advanced Menu System. Enter **95 CALL** on the keypad. You will see the **Main Menu** displayed on the screen.

Using the joystick up/down direction movement, select the **PROGRAM** menu.
Use the joystick pan right movement to enter this menu.

Now use the Joystick up/down direction movement to select **RUN PATROL**. To the right of this, is the patrol sequence number (**xx**). By moving the Joystick to the right this number can be increased from 1 ~ 6 (up to six patrols/tours can be programmed) or decreased using the left direction movement. Now press the **OPEN** button to initiate the patrol/tour sequence number.

Special Note: If you notice that some expected presets are not being incorporated in a patrol/tour, check that the SET PATROL table has been setup correctly and shows all presets for the required sequence. A full explanation of the values to be set can be found in the Advanced Menu settings under PROGRAM, SET PATROL and RUN PATROL.

TIP - To stop the PATROL just move the joystick slightly.

AUTO SCAN- How to set it up

Auto-scan scans between two points. These are not presets as per the patrol(tour) facility but auto scan selection points. You may program only one auto scan.

STEP 1 – Select the required camera by entering <camera address> and pressing the **CAM** button on the keypad.

Position the camera where you wish to start scanning from. To setup the Auto Scan you need to enter the Advanced Menu System by selecting **95 CALL** on the keypad. You will see the **Main Menu** displayed on the screen.

Using the joystick up/down direction movement, select the **PROGRAM** menu.
Use the joystick pan right movement to enter this menu.

In the PROGRAM menu select **AUTO PAN START POS** followed by pressing **CLOSE** button to save.

STEP 2 - Aim the camera where you wish to end the scanning point. Now select the PROGRAM menu **AUTO PAN END POS**, followed by **CLOSE** button to save.

Calling the Auto Scan

First you must set the start and end positions of the auto scan as above. This runs the auto scan function between these two points. There are two methods of initiating the auto scan. If you enter **97 CALL** via the keypad you can initiate the auto scan. Note that the 97 CALL will run at the speed set in the RUN AUTO PAN table.

You may also initiate the auto scan through the Advanced Menu System. Enter the Main Menu by selecting **95 CALL** on the keypad. You will see the **Main Menu** displayed on the screen.

Using the joystick up/down direction movement, select the **PROGRAM** menu.
Use the joystick pan right movement to enter this menu.

In the PROGRAM menu select **RUN AUTO PAN <speed>**. The speed is selected using the Joystick pan left or pan right. The following speed selection can be made: **FAST / NORMAL / SLOW / -FAST / -NORMAL / -SLOW**. There are 6 speed selections. The first three relate to scans up to 180° and the second three relate to scans greater than 180°. If the start position is the same as the end position it will do a 360° scan. Now press the **CLOSE** button to save and initiate the Auto Scan.

TIP - To stop the scan just move the joystick slightly.

RECORD PATTERN- What is a record pattern

This dome has an option to store a record pattern. A record pattern consists of a continuous sequence of standard pan and tilt movements or lens commands recorded within a 40 second interval. A record pattern does not use presets. You can limit movement at a required position and pan and tilt within the 40 second time restriction. Once the recording is complete, i.e you have closed the recording or the record time has expired, you may use an option in the Advanced Menu System to replay the recorded pattern. Once this recorded pattern is initiated, the dome will run the record pattern continuously until a keypad movement is detected or an alarm is activated.

RECORD PATTERN- What is the difference between a pattern & a patrol (tour)

A patrol (tour) uses presets and when initiated, the dome will move to a maximum of 16 preset positions using the speed attribute and the dwell times as set in the Program Patrol Table. The speed of dome movement between any two presets can be selected but this is a constant speed and not a variable speed. A patrol (tour) can run for an extensive length of time with a dwell time of a maximum of 99 seconds at each of sixteen preset positions. In addition up to six different patrols (tours) can be stored each with different preset parameters whereas only one record pattern can be recorded. When a preset is stored the dome stores not only the preset position but also zoom and camera attributes. A record pattern does not record zoom attributes.

A record pattern does not use presets. It however allows the user to record a continuous sequence of standard pan and tilt movements or lens commands but does not allow presets, flip, digital zoom, proportional pan or turbo speed. The record pattern sequence can be recorded using the keypad pan and tilt joystick but will only record up to a 40 second interval. A record pattern allows the user a continuous view rather than selected preset positions and is similar to an auto scan except that an auto scan only allows a selected movement speed whereas the record pattern reflects the user movements made during the recording of the record pattern.

RECORD PATTERN- How to set it up

Record Pattern allows a pattern to be recorded which consists of any standard pan and tilt or lens command within a 40 second interval. A pattern is automatically closed when the 40 second interval is exceeded or by pressing the CLOSE button. Note that the following are not allowed in a pattern: presets, flip, digital zoom, proportional pan and turbo.

STEP 1 – Select the required camera by entering <camera address> and pressing the **CAM** button on the keypad.

Position the camera where you wish to start the record pattern sequence. Enter the Advanced Menu System by selecting **95 CALL** on the keypad. You will see the **Main Menu** displayed on the screen.

Using the joystick up/down direction movement, select the **PROGRAM** menu.
Use the joystick pan right movement to enter this menu.

In the PROGRAM menu select **RECORD PATTERN** followed by pressing **CLOSE** button to save.

STEP 2 – Now move the camera using the keypad joystick to record a forty second sequence and follow this by pressing the **CLOSE** button to save. The record pattern will be stored for future replay.

Running the Record Pattern

First you must have recorded a record pattern as detailed above. This runs a record pattern of up to 40 seconds duration. You can run the Record Pattern through the Advanced Menu System. Enter the Main Menu by selecting **95 CALL** on the keypad. You will see the **Main Menu** displayed on the screen.

Using the joystick up/down direction movement, select the **PROGRAM** menu.
Use the joystick pan right movement to enter this menu.

In the PROGRAM menu select **RUN PATTERN**. Now press the **CLOSE** button to save and initiate the Record Pattern sequence. This will run continuously.

TIP - To stop the record pattern just move the joystick slightly.

USING THE DOME'S ADVANCED FUNCTIONS-

On Screen Graphics (OSD) –

The PTZ400 series boasts six patrol (tour) options, an auto scan option and a record pattern option. All these can be configured using the OSD.

To bring up the camera menu press **95 CALL**. The OSD is then displayed on the screen. You can navigate between the various options using the Joystick control – up to increase and down to decrease – right pan to enter and left pan to exit. You can also use the **OPEN** button to enter and the **CLOSE** button to save and exit.

THE ADVANCED MENU SYSTEM

Using the Advanced Menu System.

This menu system allows the user to alter the dome menu instruction options and settings using a control keypad. This first page shows the initial main menu page and only describes the general functions. The following pages show the main menu option selected on the left hand side of the page and a breakdown of that menu page on the right hand side of the page.

MAIN MENU

To enter the main menu system press **95 CALL** on the Keypad.

Use the Joystick control pan up or pan down to increase or decrease a value and pan left or pan right to enter a selection.

The OPEN button can also be used to enter a selection and the CLOSE button to exit.

To leave the main menu press EXIT in Main Menu.

DESCRIPTION OF MENU OPTIONS

DISPLAY SETUP: To set dome camera address display – set position of address – set preset title – set preset title position – open camera screen.

CAMERA SETUP: To set slow shutter – set backlight compensation – set low light shooting – auto/manual iris – digital zoom – auto/manual focus – white balance.

CONTROL SETUP: To set auto flip – alarm – preset freeze – set home function

CAMERA MASK SET: To set camera mask.

PROGRAM: Set auto pan start & end – run auto pan – edit preset title – setup patrols/tours – run patrols /tours – record pattern – run pattern.

PAL CAMERA: To switch between PAL and NTSC camera mode.

CAM DEFAULT SET: To select camera default settings.

DOME RESET: To reset the Dome titles.

EXIT: To exit menu.

MAIN MENU

1. DISPLAY SETUP
2. CAMERA SETUP
3. CONTROL SETUP
4. CAMERA MASK SET
5. PROGRAM
6. PAL CAMERA
7. CAM DEFAULT SET
8. DOME RESET
9. EXIT

DISPLAY SETUP

To access Display Setup press the **OPEN** button on keypad or move the Joystick to the right. The menu below will be displayed.

MAIN MENU

1. **DISPLAY SETUP**
2. CAMERA SETUP
3. CONTROL SETUP
4. CAMERA MASK SET
5. PROGRAM
6. PAL CAMERA
7. CAM DEFAULT SET
8. DOME RESET
9. EXIT



DISPLAY SETUP

ID DISPLAY	ON
ID POS	TOP-L
TITLE DIS	ON
TITLE POS	01 LINE
CAM DISPLAY	ON
RETURN	

DISPLAY SETUP MENU OPTIONS

ID DISPLAY ON / OFF

When set to ON the camera address of the dome appears on the screen e.g. CAM 001.

The default setting is ON. To toggle these settings move the Joystick to the right or press the OPEN button. To return to Main Menu use the Joystick down movement to RETURN and press the OPEN button on the keypad or move the Joystick to the right.

ID POS TOP-L / TOP-R / BOTT-R / BOTT-L

This allows user to position the camera address display at one of the following corners of the display: TOP-L (Top Left), TOP-R (Top Right), BOTT-R (Bottom Right) and BOTT-L (Bottom Left). To toggle these settings move the Joystick to the right or press the OPEN button. To return to Main Menu use the Joystick down movement to RETURN and press the OPEN button on the keypad or move the Joystick to the right.

TITLE DIS ON / OFF

When this is set to ON, the title of the preset point appears in the left of display when the preset is called. E.g. NO.001 ENTRANCE. The **PROGRAM** option is used to setup the title.

To toggle the settings move the Joystick to the right or press the OPEN button. To return to Main Menu use the Joystick down movement to RETURN and press the OPEN button on the keypad or move the Joystick to the right.

TITLE POS 01~10 LINE

This is used to set the display position of the preset title. Specify line number from 01 ~10.

Line 1 is at the top of the display and line 10 at the bottom. To toggle the settings move the Joystick to the right or press the OPEN button. To return to Main Menu use the Joystick down movement to RETURN and press the OPEN button on the keypad or move the Joystick to the right.

CAM DISPLAY ON / OFF

When this is set to ON the camera screen will be opened. To toggle the settings move the Joystick to the right or press the OPEN button. To return to Main Menu use the Joystick down movement to RETURN and press the OPEN button on the keypad or move the Joystick to the right.

RETURN

To return to Main Menu move the Joystick to the left or press the OPEN button.

CAMERA SETUP

Move the Joystick down to select Camera Setup and press the OPEN button or move the Joystick to the right. The menu below will be displayed.



MAIN MENU

1. DISPLAY SETUP
- 2. CAMERA SETUP**
3. CONTROL SETUP
4. CAMERA MASK SET
5. PROGRAM
6. PAL CAMERA
7. CAM DEFAULT SET
8. DOME RESET
9. EXIT

CAMERA SETUP

SLOWSHUTTER	AUTO
BACK LIGHT	OFF
ICR SHOT	AUTO
IRIS	AUTO
D-ZOOM	ON
FOCUS	AUTO
WB SET	ATW
MENU OF CAM	
RETURN	

NOTE: The following camera setup options depend on the camera type installed.

SLOW SHUTTER **AUTO / MANU**

Sets a manual shutter speed. In auto mode the electronic shutter is fixed on 1/50 sec after initialization. To toggle the settings move the Joystick to the right or press the OPEN button. To return to Main Menu use the Joystick down movement to RETURN and press the OPEN button on the keypad or move the Joystick to the right.

BACK LIGHT **ON / OFF**

Used to switch backlight compensation on or off. This can be used to improve image quality when the object viewed is dark or dim. This option allows the user to increase backlight compensation. To toggle the settings move the Joystick to the right or press the OPEN button. To return to Main Menu use the Joystick down movement to RETURN and press the OPEN button on the keypad or move the Joystick to the right.

ICR SHOT **ON / AUTO**

Low light shooting. This is used when the external brightness is extremely low. Normally the camera works in the automatic state but when the light level falls to below 1 Lux the camera can be switched to the zero luminance state. To toggle the settings move the Joystick to the right or press the OPEN button. To return to Main Menu use the Joystick down movement to RETURN and press the OPEN button on the keypad or move the Joystick to the right.

IRIS **AUTO / MANU**

Setup of automatic iris. To toggle the settings move the Joystick to the right or press the OPEN button. To return to Main Menu use the Joystick down movement to RETURN and press the OPEN button on the keypad or move the Joystick to the right.

CONTROL SETUP

Move the Joystick down to select Control Setup and press the OPEN button or move the Joystick to the right. The menu below will be displayed.

MAIN MENU

1. DISPLAY SETUP
2. CAMERA SETUP
3. CONTROL SETUP
4. CAMERA MASK SET
5. PROGRAM
6. PAL CAMERA
7. CAM DEFAULT SET
8. DOME RESET
9. EXIT

CONTROL SETUP

AUTO FLIP	ON
ALARM	ON
PRESET PIC	MOVE
HOME OPTION	
RETURN	

AUTO FLIP **ON / OFF**

This allows the setting of the 180° automatic flip of the dome camera. To toggle this setting move the Joystick to the right. To return to Main Menu use the Joystick down movement to RETURN and press the OPEN button on the keypad or move the Joystick to the right.

ALARM **ON / OFF**

This allows alarm activation to be set. To toggle this setting move the Joystick to the right. To return to Main Menu use the Joystick down movement to RETURN and press the OPEN button on the keypad or move the Joystick to the right.

PRESET PIC **FREEZE / MOVE**

Set this option to FREEZE if following a preset call, you wish to freeze the image. Otherwise set to MOVE to continue running. To toggle this setting move the Joystick to the right. To return to Main Menu use the Joystick down movement to RETURN and press the OPEN button on the keypad or move the Joystick to the right.

HOME OPTION **enter HOME OPTION sub menu**

To enter this option move the Joystick to the right. The submenu below will be displayed.

AUTO HOME **ON / OFF**

When this is set to ON the dome camera will return to home if there has been no action in a period of time. This does not apply if the dome camera is on a tour. If no home is needed when the camera is stopped, set the option to OFF.

HOME POS **01 ~ 63 or 65 ~ 128 / PATROL n**

This setting allows the user to declare a preset position as the HOME position or revert to a tour number. After an alarm has been triggered a tour can be restarted automatically. For

HOME OPTION

AUTO HOME	ON / OFF
HOME POS	01 / PATROL 1
DWELL TIME	06 MIN
RETURN	

setting a preset you will need to have previously created this preset position. To toggle this setting move the Joystick to the right. To return to Control Setup use the Joystick down movement to RETURN and press the OPEN button on the keypad or move the Joystick to the right.

DWELL TIME 1 ~ 99

This allows the user to set the time period in minutes before returning to HOME when there has been no action. To toggle this setting move the Joystick to the right. To return to Control Setup use the Joystick down movement to RETURN and press the OPEN button on the keypad or move the Joystick to the right.

RETURN return to CONTROL SETUP menu by moving Joystick to the left.

CAMERA MASK SET

This function is not available.

MAIN MENU

1. DISPLAY SETUP
2. CAMERA SETUP
3. CONTROL SETUP
- 4. CAMERA MASK SET**
5. PROGRAM
6. PAL CAMERA
7. CAM DEFAULT SET
8. DOME RESET
9. EXIT

CAMERA MASK SET

- MASK PRIVACY
- MASK SHADE
- REGION
- RETURN

MASK PRIVACY This function not available

MASK SHADE This function not available

MASK REGION This function not available

RETURN Return to MAIN MENU

PROGRAM

Move the Joystick down to select Program and press the OPEN button or move the Joystick to the right. The menu below will be displayed.



MAIN MENU

1. DISPLAY SETUP
2. CAMERA SETUP
3. CONTROL SETUP
4. CAMERA MASK SET
- 5. PROGRAM**
6. PAL CAMERA
7. CAM DEFAULT SET
8. DOME RESET
9. EXIT

PROGRAM

AUTO PAN START POS
AUTO PAN END POS
RUN AUTO PAN SLOW
SET TITLE XX
SET PATROL XX
RUN PATROL XX
RECORD PATTERN
RUN PATTERN
RETURN

AUTO PAN START POS

To set the start position of an auto scan between two points, move the camera to the start position after selecting this option using the keyboard Joystick. Then press the CLOSE button.

AUTO PAN END POS

To set the end position of an auto scan between two points, move the camera to the end position after selecting this option using the keyboard Joystick. Then press the CLOSE button.

RUN AUTO PAN FAST / NORMAL / SLOW / -FAST / -NORMAL / -SLOW

This runs the auto scan function between two points. First you must set the start and end positions of the auto scan as above. If the start position is the same as the end position it will do a 360° scan. There are 6 speed selections. The first three relate to scans up to 180° and the second three relate to scans greater than 180°. The speed is selected using the Joystick pan left or pan right and to initiate the auto scan press the OPEN button.

SET TITLE

To edit titles of preset positions. Only 63 preset titles can be edited. Select preset point number using the Joystick pan left or pan right, press OPEN button to enter **EDIT MODE** and CLOSE to exit.

EDIT PRESET POINTS

To edit title of preset point. Move cursor using the Joystick pan left or pan right and modify the title using the Joystick UP/DOWN controls. Press CLOSE button to save modifications and exit. The title can be up to 8 characters long, consisting of

PRESET NO: 01
TITLE: NO TITLE

CLOSE:EXIT

0-9, A-Z, +, - and space.

NOTE: The first character of the title must be 0-9 or A-Z.

SET PATROL

To edit data for a patrol/tour. Select sequence number of patrol by using the Joystick pan left or pan right, press OPEN button to select edit mode and edit using the up/down Joystick movement, setting the POS (preset number), the Joystick pan right to select the dome speed (SP) and the dwell time (TM) followed by the CLOSE button to save and exit.

EDIT PATROL SEQUENCE

To edit a patrol sequence

NO Patrol Item No.
POS No. of preset position
SP Dome speed (0, 1~8)
0 and 1 are fastest speed –
8 is slowest speed
TM Dwell time at this position
Time 0 ~ 99 seconds

NO	POS	SP	TM	POS	SP
01	001	01	01	002	01
03	003	01	01	004	01
05	---	--	--	---	--
07	---	--	--	---	--
09	---	--	--	---	--
11	---	--	--	---	--

SEQ:nn The Patrol number. (1 ~ 6)

Note that two patrol points are set on each line of this menu. The CLOSE button closes and stores the new settings. The program searches for the first --- and any data following is regarded as invalid data. In the example above the program stores four preset positions numbers 01~04. However the settable range can be from 1 to 63 and from 65 to 128. You can set up to 16 preset positions per Patrol sequence and you can have up to 6 patrol sequences.

RUN PATROL

To run a multi-point patrol select the Sequence Number of the Patrol using the Joystick pan left and pan right, and run using the OPEN button.

Special Note: If you notice that some expected presets are not being incorporated in a patrol/tour, check that the SET PATROL table has been set up correctly and shows all presets for the required sequence.

RECORD PATTERN

This option allows a pattern to be recorded which consists of any standard pan and tilt or lens command. **Presets, flip, digital zoom, proportional pan and turbo are not allowed in a pattern.** The pattern length lasts for 40 seconds maximum and returns after this period or by pressing the CLOSE button.

RUN PATTERN

This option initiates the recorded pattern. To exit the menu or stop running, move the Joystick.

RETURN Return to Main Menu.

PAL CAMERA

No sub-menu option for this.

MAIN MENU

1. DISPLAY SETUP
2. CAMERA SETUP
3. CONTROL SETUP
4. CAMERA MASK SET
5. PROGRAM
- 6. PAL CAMERA**
7. CAM DEFAULT SET
8. DOME RESET
9. EXIT

PAL / NTSC CAMERA

To switch from PAL to NTSC camera use the Joystick pan left or pan right. Note that PAL is the UK standard. Press the CLOSE button to exit or move down using the up and down toggle to move to the EXIT point.

CAM DEFAULT SET

No sub-menu option for this.

MAIN MENU

1. DISPLAY SETUP
2. CAMERA SETUP
3. CONTROL SETUP
4. CAMERA MASK SET
5. PROGRAM
6. PAL CAMERA
- 7. CAM DEFAULT SET**
8. DOME RESET
9. EXIT

CAM DEFAULT SET

This option sets the camera default settings. Press the CLOSE button to exit or move down using the up and down toggle to move to the EXIT point.

DOME RESET

MAIN MENU

1. DISPLAY SETUP
2. CAMERA SETUP
3. CONTROL SETUP
4. CAMERA MASK SET
5. PROGRAM
6. PAL CAMERA
7. CAM DEFAULT SET
- 8. DOME RESET**
9. EXIT

DOME RESET

This option resets the DOME settings. The following display will be output 

Use the Joystick left or right pan to toggle between YES and NO. Press the CLOSE button to initiate the required option.

THE OPERATION WILL
CLEAR ALL TITLES
DO YOU WANT TO
CONTINUE ?

YES NO

EXIT

MAIN MENU

1. DISPLAY SETUP
2. CAMERA SETUP
3. CONTROL SETUP
4. CAMERA MASK SET
5. PROGRAM
6. PAL CAMERA
7. CAM DEFAULT SET
8. DOME RESET
- 9. EXIT**

Use the Joystick to select the option and press the CLOSE button to exit menu.

Controlling one camera then another.

If you look at the image of the LCD display you can see the CAM=001 indicates that the keyboard is ready to talk to camera address 1. In the dome the address 1 is set as default in the factory. You need to alter the DIP-switches within the domes to address 2, 3 etc if you have multiple domes on the same site, refer to the previous instructions how to set the DIP Switches. If you have another dome set at camera address 2, press 2 followed by CAM. This would change the screen to CAM=002. And so on.



with
You

Physical installation of the dome –

1. The Style of the Installation

1) Dimension of the Product

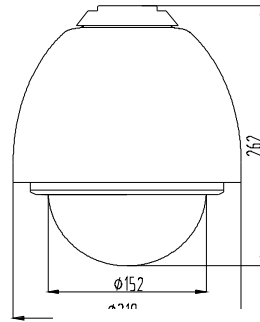

2) The Style c

a) Wall Ir

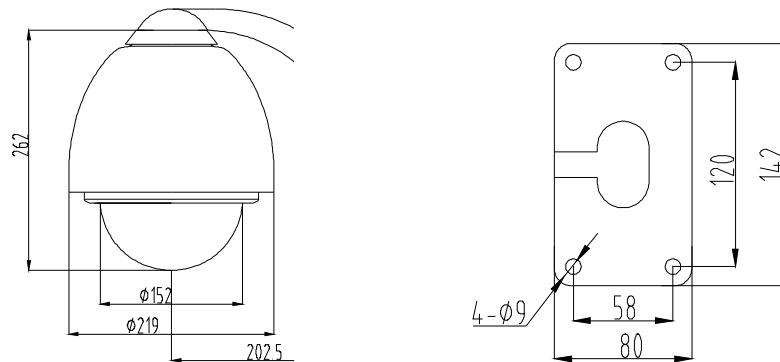

Figure 4

b) In-Ceiling Installation

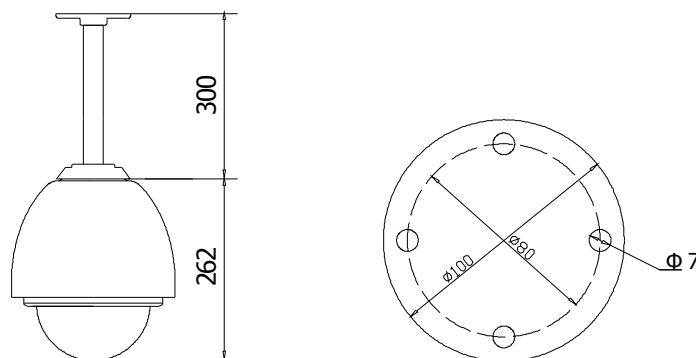

Figure 5

c) Indoor Ceiling Installation

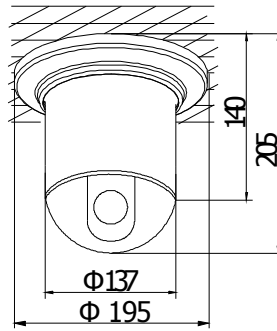

Figure 6

d) Indoor Embedded Installation

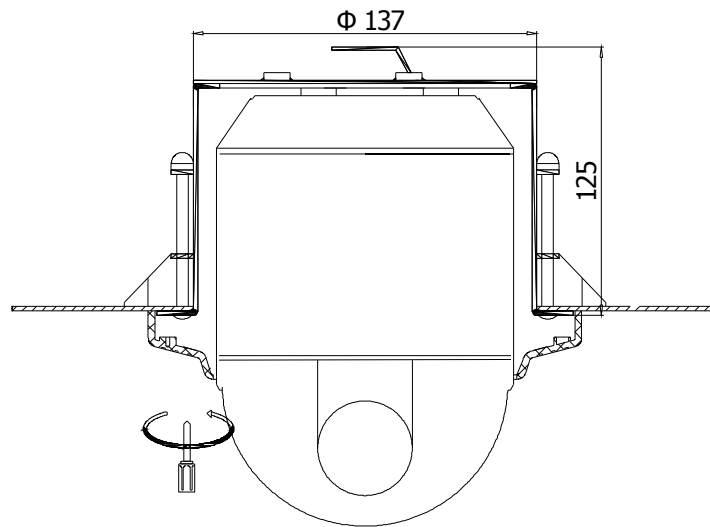

Figure 6-1

2. Installation Steps (taking wall-install style as example)

- 1) Unpack the carton and carefully take out the dome camera and its attachments.
- 2) Take out the cover of the wall-installed bracket (see Figure 7).
- 3) Take out system control wires from the bracket (see Figure 8).
- 4) Fix the bracket on the wall (see Figure 9).

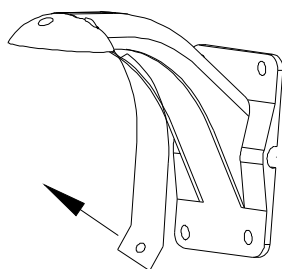

Figure 7

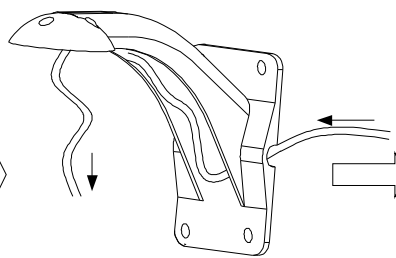

Figure 8

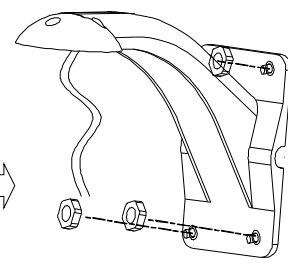
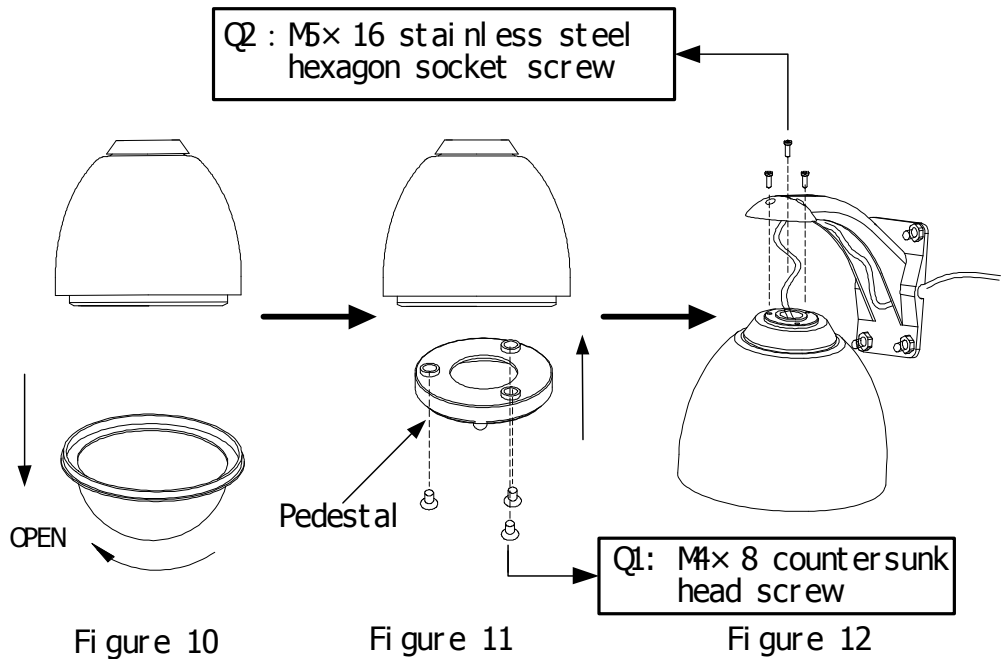
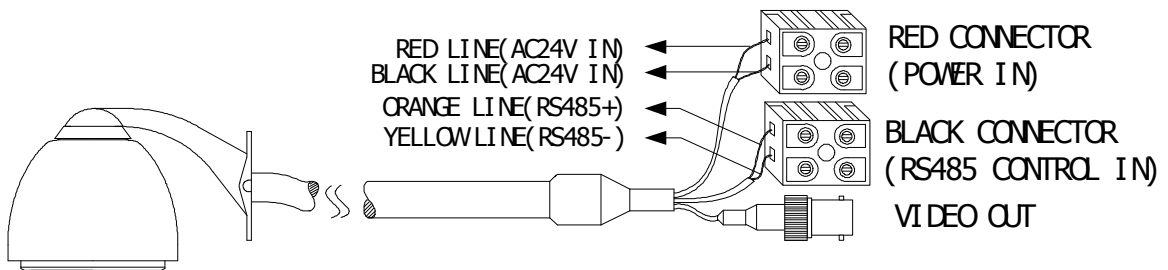
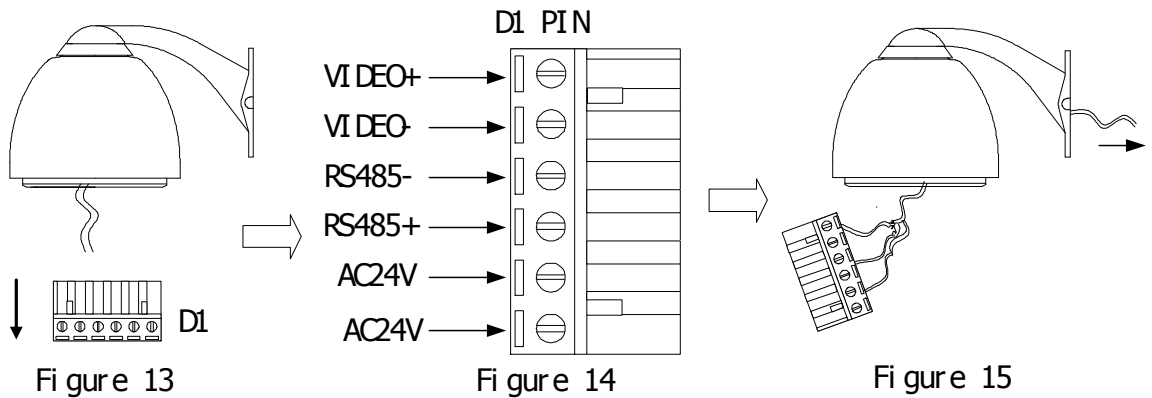

Figure 9

- 5) Rotate the vitreous cover counterclockwise and take it out. (see Figure 10)
- 6) Fix the pedestal in the aluminum alloy ball (Figure 11). Install the ball on the bracket (Figure 12).



- 7) Take out the "plug and play" connector D1 (Figure 13).
- 8) Connect the control wires of the system as per Figure 14.
- 9) Insert connector D1 into the corresponding socket. Take care not to leave wires inside the ball cover but to pull them out of the cover as shown on Figure 15.



- 10) Insert attachment plug into socket D2 on the aluminum alloy assembly. Refer (Figure 15-1).

11) **4 channel alarm input activation & single channel alarm output**

One of the special features of this dome is that it has four in-built alarm channels to call four independent presets. This means that for example you may have a door contact and when the contact is closed, it sends a 0 volt alarm switch to the dome on one of the four alarm channels. The dome will then call a previously set preset position and lock the camera onto that position. A single channel alarm out, allows the connection of an audible alarm, lighting or other warning device. When more than one alarm input channel is utilised and activated, the dome will switch to the next channel after two seconds. However once an alarm input channel has been activated, the dome will remain locked to the preset position/s and will not resume a patrol, auto scan or a record pattern until the alarm condition is cleared. However the HOME Option in the dome menu can be set to restart a tour if necessary.

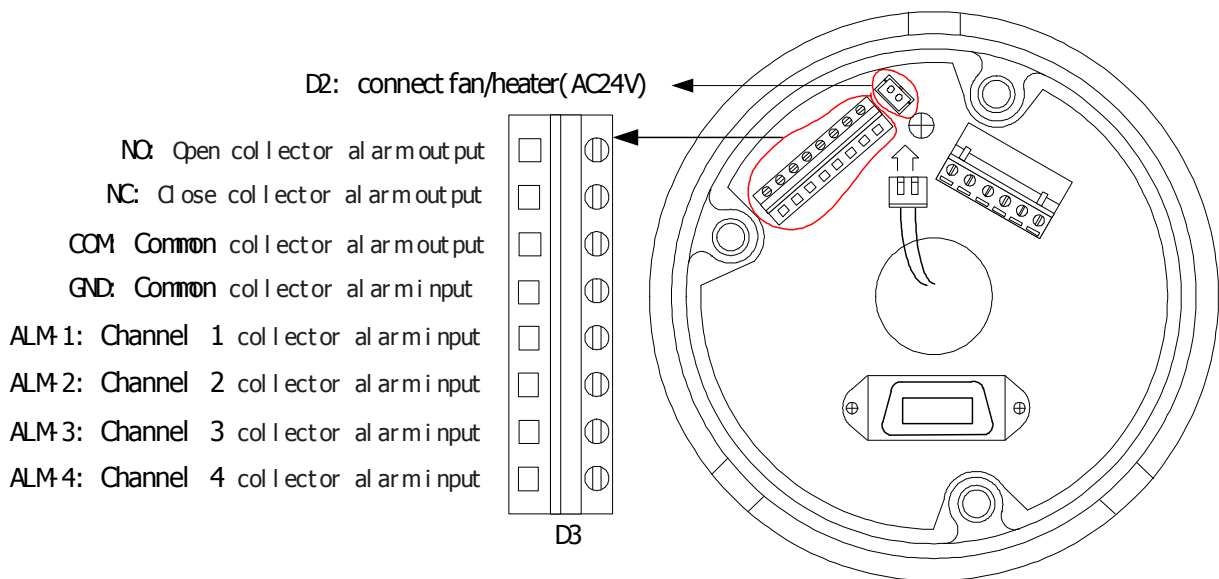

Figure 15-1

12) **Connecting the Input Alarm devices**

Refer to Fig 15-1 to locate the D3 connector. You will need to decide how many alarm channels will be utilised. For each alarm channel you will need a pair of cable connections and it is recommended that a CAT5 twisted pair be utilised. Connect one core to the selected input alarm channel and the other to the ground (GND) connection. The ground is a common connection for all four alarm channels. At the alarm end (see Fig 15-2) connect to the alarm device. This must be a 0 volt switch and maybe for example a door switch. Check that the alarm device passes a voltage free switch as any other input signal may damage the dome.

NOTE: THE ALARM INPUT MUST BE VOLTAGE FREE OR YOU MAY DAMAGE THE DOME.

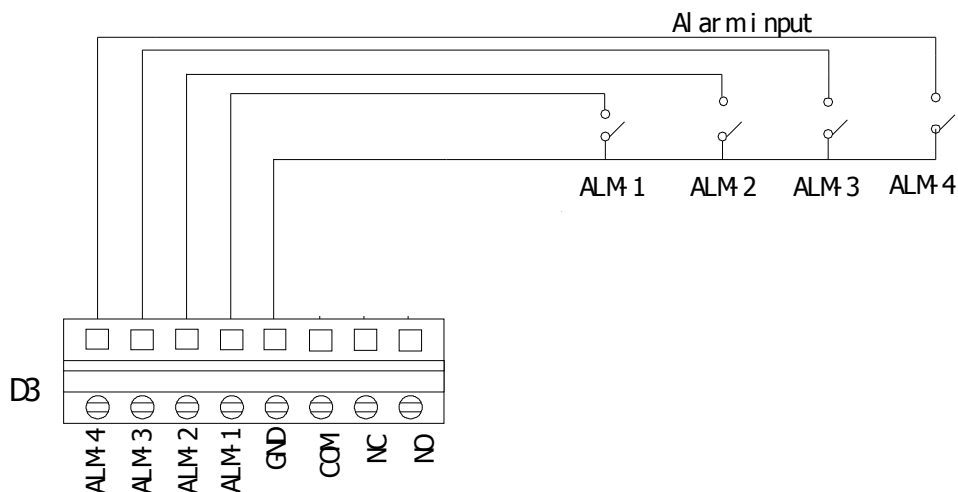

Figure 15-2

Each of the four alarm channels call a different dedicated preset number when the 0v switch is detected by the dome. This allows the dome to move immediately to the selected preset position in an alarm condition. The following alarm channels call the stipulated preset number when activated:

- when Alarm Channel No 1 is activated it calls preset number 29
- when Alarm Channel No 2 is activated it calls preset number 30
- when Alarm Channel No 3 is activated it calls preset number 31
- when Alarm Channel No 4 is activated it calls preset number 32.

To set these special presets, if you have set up alarm channel 1, move the dome camera to where you wish alarm 1 preset to move to, and using the keypad press 29 followed by the Preset button. Then if you have set up alarm channel 2, move the dome camera to where you wish alarm 2 preset to move to, and using the keypad press 30 followed by the Preset button and so on.

When more than one alarm channel is utilised and activated, the dome will respond to each alarm by calling the relevant preset and switching to the next preset after two seconds. The dome will lock on to the last alarm activated and will not resume a patrol, auto scan or record pattern until the alarm condition is cleared or the HOME option set in the dome menu to restart a tour/patrol.

Example: Connecting Alarm 1 channel to a door contact

Here is an example scenario. A company requires a dome to run a patrol (tour) continuously viewing four preset points. One of the preset points is the main entrance door to the building. The requirement is to ensure that during out of hours the entrance door is not breached. The dome alarm 1 channel is connected to a door contact on the main entrance door. A CAT5 twisted pair is connected at the dome end to the ALM1 and GND connection on the D3 connector. At the door contact end the twisted pair is connected either way round. The dome is then set up for a tour using presets 01 to 04 and called TOUR 1. In addition preset 29 is set up focusing the dome camera at the door entrance. When the building is vacated the dome is left running a tour of the four presets. If the door contact is closed a voltage free switch is made on the Alarm 1 channel. The dome then automatically calls preset 29 which locks onto the main entrance door. As the HOME OPTION menu has been set to HOME POS Tour 1, DWELL time 6 minutes,

after the alarm is triggered for 6 minutes, the dome will revert to TOUR 1.

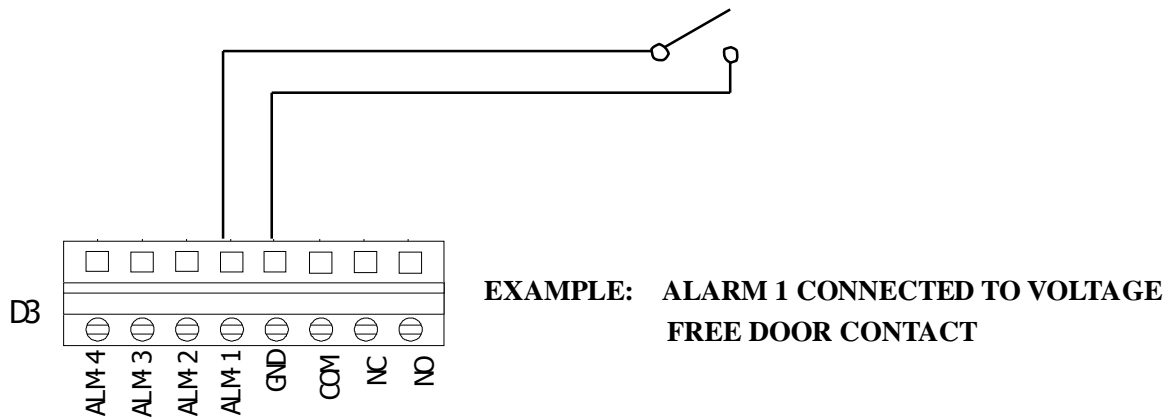

13) Connecting the Output Alarm

In addition to the alarm inputs, this dome will activate an alarm output if an alarm input is triggered. There are two connections for the alarm output, a common and either a normally open or a normally closed connection. Again this is a 0 volt switch and could be used for example to close a circuit to an audible alarm, lighting or other warning devices. Ensure that the switch line does not carry any voltage. Again this switch remains activated until the input alarm/s have been cleared/reset.

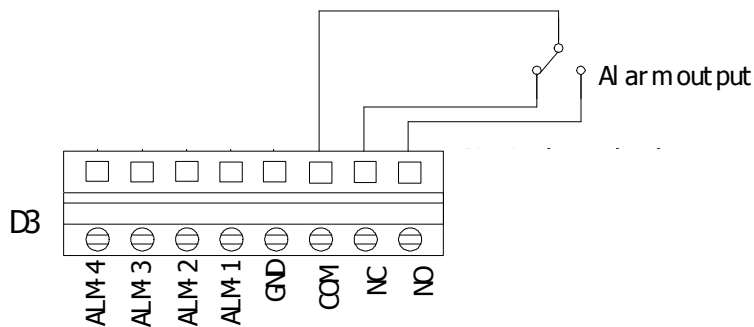

NOTE: You do not have to use the alarm output feature when using alarm inputs.

14) Based on the coding switches shown in Figure 2, set up the protocol used by the camera and the baud rate as per the settings in Table 2. Check the address of the camera to see if it needs changing to meet the requirements of your system. If it does, set the address of the dome camera according to the settings in Table 1.

15) **Rotate the vitreous cover on dome counterclockwise and take it off.**

Note: If the Speed Dome Camera is fixed in the aluminum alloy ball, you must take off the vitreous cover on the dome. Otherwise, it will effect picture quality. (see Figure 16)

16) Aligning the “MARK” on the ball with the notch on the pedestal, push the ball upward to the end and rotate clockwise until it clicks into place, then mount the vitreous cover by rotating it clockwise (as shown on Figure 17), and mount the cover plate of the bracket last (see Figure 18).

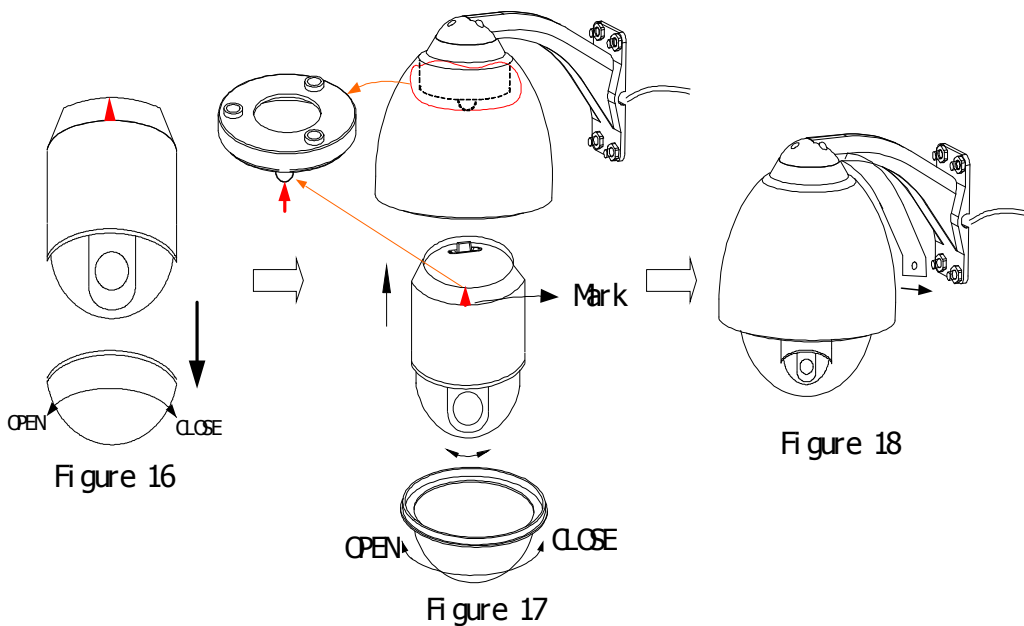

VI. Technical data table

Specifications	Image Inductor	Depends on camera type fitted
	Pixels	Depends on camera type fitted
	In-Phase System	In-Phase Inside
	Video Output	1.0 Vp-p/75 Ω
	White Balance	Auto / Manual
	Power Supply	AC 24V ± 10% 1.25A (with fan/heater)
	Power Consumption	30 VA (with fan/heater)
		15 VA (indoor)
	Weight	2 Kg
		4 Kg (with aluminum alloy ball)
	Installation	Indoor ceiling installation or wall mounting
	Opposite Humidity	10-75 %
Environment Temperature	0°C ~40°C	
Dome Function	Pan Speed	0~300°/s
	Tilt Speed	0~120°/s
	Preset	128 presets (max)
	Auto Cruise	At best 6 cruises
	Pattern	40 sec.

Appendix A: Lightning Proof and Surge Signal Proof

This product adopts TVS lightning proof technology to prevent damage by a lightning strike below 1500 W and surge impulse signals. However it is also necessary to ensure that the following precautions are taken to ensure electrical safety:

- Keep the communication cables at least 50 meters away from high voltage equipment or cables.
- Where possible locate outdoor cables under eaves to provide best protection.
- In an open area run cables in steel tubing and attach a single point ground to the tube.
- In areas prone to thunderstorms or high EMF (such as a high voltage transformer substation), additional lightning proof equipment must be installed.
- Always design the installation taking account of the building lightning proof requirements and grounding of outdoor equipment in accordance with the national and industrial standards.
- The system must be grounded with equal potentials. The earth ground connection must satisfy anti-interference and electrical safety requirements and must not short circuit the high voltage electricity network. When the system is grounded separately, the resistance of the down conductor should be $\leq 4 \Omega$ and the sectional size of the down conductor should be $\leq 25\text{mm}^2$ (refer to Fig 36).

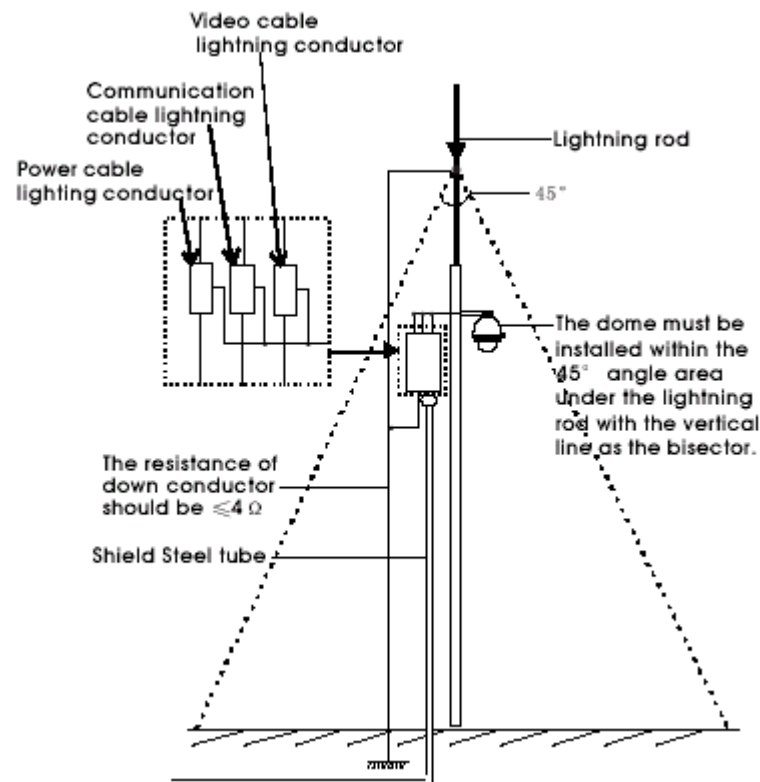

Figure 36

NOTE: This technology HELPS prevent the dome and camera from being damaged by lightning strikes but under no circumstances does it guarantee protection. Domes or cameras struck by lightning will not be covered by the warranty.

Appendix B: General Information

The Cleaning of Clear Dome Cover

To obtain constant clear images, the user should clean the dome cover periodically.

- Be very careful when cleaning. Hold the dome cover ring only to avoid touching the acrylic dome cover. The acid from fingerprints will corrode the coating and any scratches on the dome cover may cause distorted or poor images.
- Use a soft dry cloth or a similar to clean the inner and outer surfaces.
- For more stubborn contamination, use a neutral detergent. Any cleanser for high-grade furniture is applicable.

Technical data table

Spec	Image inductor	Colour CCD
	Pixels	Depends on module
	In-phase system	In-phase inside
	Video out	1.0Vp-p/75 Ω
	White balance	Auto/manual
	Power supply	AC24V ± 10% 1.25A
	Power consumption	30VA (including the heater device)
	Weight	4Kg
	Installation	Wall mounting
	Opposite humidity	10-75%
	Environment temp	0c ~ 40c
Dome Function	Pan speed	0.2 - 300 rad/s
	Tilt speed	0.2 – 120 rad/s
	Presets	128 presets(max)
	Patrols/Tours	6 maximum – 16 presets per patrol/tour
	Auto scan	Yes

**The new 22x PTZ module for the
Pan, Tilt and Zoom ranges of domes.**

Camera Instruction Manual.



1. OSD Navigation.

The way to navigate to the menu options is dependant on the model of PTZ that the module has been installed in.

1.1 The PTZ300 and PTZ500 Series.

When the module is installed in the PTZ300 and PTZ500 series the OSD menu is accessed by **CALL 57** from a keypad that is connected to the PTZ via RS485 comms.

Navigation is done by the **TELE & WIDE** buttons and selection is made with the **NEAR & FAR** buttons.

To exit the OSD menu use **CALL 57** on the keypad.

1.2 The PTZ400 and PTZ600 Series.

When the module is installed in the PTZ400 and PTZ600 series the OSD menu is accessed by **CALL 95** from a keypad that is connected to the PTZ via RS485 comms.

This will enter the menu system of the PTZ. Go to the **CAMERA MENU**, navigation is done by the joystick **UP & DOWN** and selection is made by moving the joystick **RIGHT**. Once in the camera menu go to the **MENU OF CAM** option and move the joystick **RIGHT**. Now you are in the module menu, navigation is done by the **TELE & WIDE** buttons and selection is made with the **NEAR & FAR** buttons.

To exit the OSD menu press the **CLOSE** button on the keypad.

2. The module Menu Structure.

Once in the menu system of the camera module the following options are available.

MENU OF CAM

- 1. BACKLIGHT (OFF,ON)
- 2. SLOW SHUTTER (OFF or 2 to 128)
- 3. DAY/NIGHT (OFF,ON,AUTO)
- 4. WB CONTROL (PUSH,AUTO)
- 5. SHUTTER (AUTO)
- 6. CAMERA ID (NUMERIC 3 DIGIT 000 to 255)
- 7. ZOOM START (x001 to x022)
- 8. ZOOM STOP (x001 to x220)
- 9. BRIGHTNESS (1 to 48)
- 10. SHARPNESS (0 to 18)
- 11. FOCUS (PUSH or AUTO)
- 12. INIT SET (OFF or ON)

BACKLIGHT Used to switch backlight compensation on or off. This can be used to improve image quality when the light behind the object causes the object to appear dark or dim.

SLOW SHT This setting allows the module to slow the shutter speed down or to turn the slow shutter off. The range of shutter speeds range from 2 to 128.

DAY/NIGHT This option is used to set the module to either switch automatically between day and night mode depending upon the level of light available. (AUTO) will stay in colour during the day and switch to black & white at night, (OFF) will stay in colour mode and (ON) will stay in black and white mode.

WB CONTROL This option is used to determine how the white balance is controlled by the module. When set to AUTO the module will automatically alter the white balance in relation to the amount of light in the image, whereas when set to PUSH the module will only set the white balance once when the camera has moved into position.

SHUTTER Always set to AUTO.

CAMERA ID A numeric identifying number between 0 and 255 which is then displayed on the screen.

ZOOM START This option is the setting of the minimum zoom that the module will allow x1 to x22. For example if this is set to x5 the operator will not be able to use the x1 to x4 modes when using the WIDE & TELE buttons.

ZOOM STOP	This option is the setting of the maximum zoom that the module will allow x1 to x220. For example if this is set to x22 the operator will only be able to zoom to the limit of the optical zoom and not the digital zoom up to x300.
BRIGHTNESS	This alters the brightness of the image output from the module from 0 to 48, where 0 is the darkest and 48 the brightest.
SHARPNESS	This adjusts the sharpness of the image from 0 (low) to 15 (high).
FOCUS MODE	When set to PUSH the camera module will do a single push to focus the camera and will not try to refocus after the initial push. When set to AUTO the camera will automatically focus.
INIT SET	When switched ON this option will reset all of the options within the menu back to their factory default setting.

**The new 22x PTZ module for the
Pan, Tilt and Zoom ranges of domes.**

Camera Instruction Manual.



1. OSD Navigation.

The way to navigate to the menu options is dependant on the model of PTZ that the module has been installed in.

1.1 The PTZ300 and PTZ500 Series.

When the module is installed in the PTZ300 and PTZ500 series the OSD menu is accessed by **CALL 57** from a keypad that is connected to the PTZ via RS485 comms.

Navigation is done by the **TELE & WIDE** buttons and selection is made with the **NEAR & FAR** buttons.

To exit the OSD menu use **CALL 57** on the keypad.

1.2 The PTZ400 and PTZ600 Series.

When the module is installed in the PTZ400 and PTZ600 series the OSD menu is accessed by **CALL 63** from a keypad that is connected to the PTZ via RS485 comms.

This will enter the **CAMERA MODULE MENU** and navigation is done by the **TELE & WIDE** buttons and selection is made with the **NEAR & FAR** buttons.

To exit the menu press the **EXIT** button on the keypad.

2. The module Menu Structure.

Once in the menu system of the camera module the following options are available.

MENU OF CAM

- ➔ 1. BACKLIGHT (OFF,ON)
- ➔ 2. SLOW SHUTTER (OFF or 2 to 128)
- ➔ 3. DAY/NIGHT (OFF,ON,AUTO)
- ➔ 4. WB CONTROL (PUSH,AUTO)
- ➔ 5. SHUTTER (AUTO)
- ➔ 6. CAMERA ID (NUMERIC 3 DIGIT 000 to 255)
- ➔ 7. ZOOM START (x001 to x022)
- ➔ 8. ZOOM STOP (x001 to x220)
- ➔ 9. BRIGHTNESS (1 to 48)
- ➔ 10. SHARPNESS (0 to 18)
- ➔ 11. FOCUS (PUSH or AUTO)
- ➔ 12. INIT SET (OFF or ON)

BACKLIGHT Used to switch backlight compensation on or off. This can be used to improve image quality when the light behind the object causes the object to appear dark or dim.

SLOW SHT This setting allows the module to slow the shutter speed down or to turn the slow shutter off. The range of shutter speeds range from 2 to 128.

DAY/NIGHT This option is used to set the module to either switch automatically between day and night mode depending upon the level of light available. (AUTO) will stay in colour during the day and switch to black & white at night, (OFF) will stay in colour mode and (ON) will stay in black and white mode.

WB CONTROL This option is used to determine how the white balance is controlled by the module. When set to AUTO the module will automatically alter the white balance in relation to the amount of light in the image, whereas when set to PUSH the module will only set the white balance once when the camera has moved into position.

SHUTTER Always set to AUTO.

CAMERA ID A numeric identifying number between 0 and 255 which is then displayed on the screen.

ZOOM START This option is the setting of the minimum zoom that the module will allow x1 to x22. For example if this is set to x5 the operator will not be able to use the x1 to x4 modes when using the WIDE & TELE buttons.

ZOOM STOP	This option is the setting of the maximum zoom that the module will allow x1 to x220. For example if this is set to x22 the operator will only be able to zoom to the limit of the optical zoom and not the digital zoom up to x300.
BRIGHTNESS	This alters the brightness of the image output from the module from 0 to 48, where 0 is the darkest and 48 the brightest.
SHARPNESS	This adjusts the sharpness of the image from 0 (low) to 15 (high).
FOCUS MODE	When set to PUSH the camera module will do a single push to focus the camera and will not try to refocus after the initial push. When set to AUTO the camera will automatically focus.
INIT SET	When switched ON this option will reset all of the options within the menu back to their factory default setting.

**The 22x IR PTZ module for the Pan,
Tilt and Zoom ranges of domes.**

Camera Instruction Manual.



1. OSD Navigation.

The way to navigate to the menu options is dependant on the model of PTZ that the module has been installed in.

1.1 The PTZ300 and PTZ500 Series.

When the module is installed in the PTZ300 and PTZ500 series the OSD menu is accessed by **CALL 57** from a keypad that is connected to the PTZ via RS485 comms. Navigation is done by the **TELE & WIDE** buttons and selection is made with the **NEAR & FAR** buttons.

To exit the OSD menu use **CALL 57** on the keypad.

1.2 The PTZ400 and PTZ600 Series.

When the module is installed in the PTZ400 and PTZ600 series the OSD menu is accessed by **CALL 95** from a keypad that is connected to the PTZ via RS485 comms.

This will enter the menu system of the PTZ. Go to the **CAMERA MENU**, navigation is done by the joystick **UP & DOWN** and selection is made by moving the joystick **RIGHT**. Once in the camera menu go to the **MENU OF CAM** option and move the joystick **RIGHT**. Now you are in the module menu, navigation is done by the **TELE & WIDE** buttons and selection is made with the **NEAR & FAR** buttons.

To exit the OSD menu press the **CLOSE** button on the keypad.

2. The module Menu Structure.

Once in the menu system of the camera module the following submenus are available.

2.1 The FOCUS Menu.

This menu is for configuring the following module settings;

- FOCUS SET → FOCUS MODE (AUTO,PUSH AUTO,MANUAL)
- FOCUS DIST (1CM,10CM,50CM,1M,3M,5M,10M)
- ZOOM START (x1 TO x21)
- ZOOM END (x2 TO x352)
- ZOOM SPEED (SLOW,NORMAL,HIGH)
- ZOOM TRACK (NOT USED)
- INITIAL SET (OFF OR ON)

FOCUS MODE Set up of automatic focus option. This allows the user to control the adjustment of the focus automatically by the module (AUTO) or when set to (PUSH AUTO) the camera module will do a single push to focus the camera and will not try to refocus after the initial push or to allow the operator to adjust the focus manually using the NEAR & FAR buttons on the keypad (MANUAL).

FOCAL DISTANCE This option is to set the range of focus distance that the camera will focus to when performing an auto focus. The options are 10m, 5m, 3m, 1m, 50cm, 10cm and 1cm. For example if the focal distance is set to 50cm the module will try to focus within 50cm of the focused object. Note that if a tour or autoscan is used then set distance to 5m or 10m otherwise the unit will not have time to focus.

ZOOM START This option is the setting of the minimum zoom that the module will allow x1 to x21. For example if this is set to x5 the operator will not be able to use the x1 to x4 modes when using the WIDE & TELE buttons.

ZOOM END This option is the setting of the maximum zoom that the module will allow x2 to x352. For example if this is set to x22 the operator will only be able to zoom to the limit of the optical zoom and not the digital zoom up to x352.

ZOOM SPEED This setting is the speed of the modules zoom function.

INITIAL When switched ON this option will reset all of the options within the FOCUS SET menu back to their default setting.

2.2 AWB SET (automatic white balance).

This menu is for configuring the following module settings;

- AWB SET → WB MODE (AUTO,PUSH AUTO,MANUAL,OUTDOOR,INDOOR,HUE CONTROL)
- HUE CONTROL (0 TO 99 WHEN WB MODE IS SET TO HUE CONTROL)
- RED GAIN (0 TO 255 WHEN WB MODE IS SET TO MANUAL)
- BLUE GAIN (0 TO 255 WHEN WB MODE IS SET TO MANUAL)
- PUSH AUTO (OFF OR ON WHEN WB MODE IS SET TO PUSH AUTO)
- INITIAL SET (OFF OR ON)

WB MODE This option is used to instruct the module of the environment in which it is installed and which mode to use to adjust the white balance of the image output. The options are AUTO, PUSH AUTO, MANUAL, INDOOR, OUTDOOR or HUE CONTROL.

HUE CONTROL Hue control is used to alter the definition of the colour on the image from 0 to 99. This can only be used when WB MODE is set to HUE CONTROL.

RED CONT When the WB mode is set to MANUAL this option is used to control the amount of the RED image output by the module. Setting is from 0 (0% red) to 255 (100% red).

BLUE CONT When the WB mode is set to MANUAL this option is used to control the amount of the BLUE image output by the module. Setting is from 0 (0% blue) to 255 (100% blue).

PUSH AUTO Used to select PUSH AUTO mode when WB MODE is set to PUSH AUTO.

INITIAL When switched ON this option will reset all of the options within the AWB menu back to their default setting.

2.3 A E SET(automatic exposure).

This menu is for configuring the following module settings;

- AE MODE (AUTO,MANUAL,AGC MAN,IRIS MAN)
- IRIS ADJUST (56 TO 250 WHEN AE MODE IS SET TO MANUAL OR IRIS MAN)
- AGC MAXIMUM (28 TO 255)
- BRIGHTNESS (0 TO 99)
- BACKLIGHT (OFF, SUPER, AUTO, ON)
- BLC LEVEL (0 TO 80)
- BLC AREA (CENTER,RIGHT,LEFT,BOTTOML,BOTTOMS,TOPL,TOPS)
- FLICKERLESS (OFF OR ON)
- SHUTTER (NORMAL OR 1/125 TO 1/30000)
- INITIAL SET (OFF OR ON)

- AE MODE** This option is used to select the exposure mode to be used by the camera. The options are AUTO, MANUAL, AGC MAN and IRIS MAN. When the AUTO mode is selected then the module will automatically adjust the iris and automatic gain control (AGC). When in MANUAL the iris and AGC will adjust to the user presets as defined below. When set to AGC MAN the iris control will be set automatically but the AGC will adjust only up to the AGC MAXIMUM level defined below. When set to IRIS MAN the AGC control will be done by the module automatically but the iris will adjust to the IRIS ADJUST defined below.
- IRIS ADJUST** When the AE MODE is set to MANUAL or IRIS MANUAL this is used to open and close the iris manually from 56 to 250.
- AGC MAXIMUM** This option is used to adjust the maximum limit of the automatic gain control (AGC) from 28 to 255, when the AE MODE is set to MANUAL or AGC MAN.
- BRIGHTNESS** This alters the brightness of the image from 0 to 99, where 0 is the darkest and 99 the brightest.
- BACKLIGHT** When there is strong backlight behind the object, clear images of the background and object can still be obtained by using the BACKLIGHT function. The options are OFF, ON, AUTO and SUPER.
- BACKLIGHT AREA** This option lets the camera know the position where the strong backlight is.
- FLICKERLESS** This mode of operation of a camera eliminates flicker, and therefore potential "movement" detected by a camera or DVR. This option turns the FLICKERLESS mode on or off.
- SHUTTER** This option allows the module to run on a slow shutter speed. The options are NORMAL or 1/125 to 1/30000.
- INITIAL** When switched ON this option will reset all of the options within the AE menu back to their default setting.

2.4 SPECIAL SET.

This menu is for configuring the following module settings;

- SPECIAL SET
- USER TITLE (10 DIGIT ALPHA NUMERIC LABEL)
 - SHARPNESS (0 TO 15)
 - NEGATIVE (OFF OR ON)
 - WIDE BURST (OFF OR ON)
 - INITIAL SET (OFF OR ON)

USER TITLE	A ten digit alpha-numeric label which will appear on the OSD of the camera in the bottom left of the screen.
SHARPNESS	This adjusts the sharpness of the image from 0 (low) to 15 (high).
NEGATIVE	This option will output a negative image when turned ON.
INITIAL	When switched ON this option will reset all of the options within the SPECIAL menu back to their default setting.

2.5 F OSD DISP (On Screen Display).

This menu is for configuring the following module settings;

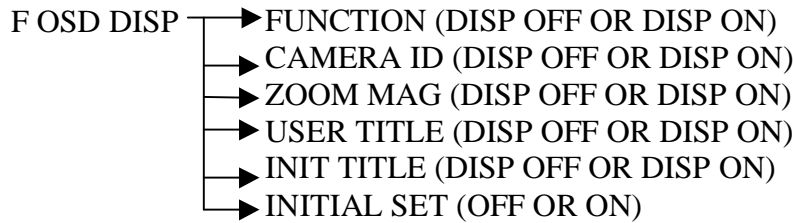

FUNCTION	When this is set to ON the module will overlay the function parameter on the output image.
CAMERA ID	When this is set to ON the module will overlay the camera id on the output image.
ZOOM MAG	When this is set to ON the module will overlay the current zoom magnification on the output image.
USER TITLE	When this is set to ON the module will overlay the USER TITLE (which is set from the SPECIAL menu) on the output image.
INIT TITLE	When this is set to ON the module will overlay the USER TITLE when the ptz is initialising.
INITIAL	When switched ON this option will reset all of the options within the OSD DISP menu back to their default setting.

2.6 DAY/NIGHT (day and night).

This menu is for configuring the following module settings;

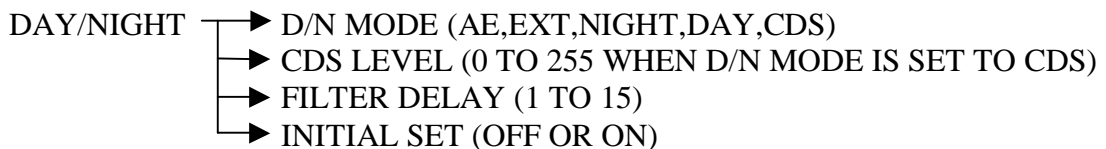

D & N MODE This option is used to set the module to either switch automatically between day and night mode depending on the level of light available. (AUTO) sets colour during the day and switches to black and white at night. CDS mode will allow the user to define the point at which the module will switch between day and night. DAY makes the module stay in colour mode and NIGHT makes the module stay in black and white mode.

CDS LEVEL Cadmium Sulphide (CdS) cells rely on the materials ability to vary its resistance according to the amount of light striking the cell. The CdS level from 0 to 255, will alter the point of which the module switches between day and night mode when the D & N mode is set to CDS.

FILTER DELAY This setting allows you to determine the time delay of the switch over from day to night mode, or night to day mode, once the switching point has been reached. 1 to 15 seconds.

INITIAL When switched ON this option will reset all of the options within the D & N menu back to their default setting.

2.7 INITIAL.

INITIAL SET This menu is for resetting the module back to the factory default settings by turning this setting ON.

The 22x IR High Resolution PTZ module for the Pan, Tilt and Zoom ranges of domes.

Camera Instruction Manual.



1. OSD Navigation.

The way to navigate to the menu options is dependant on the model of PTZ that the module has been installed in.

1.1 The PTZ300 and PTZ500 Series.

When the module is installed in the PTZ300 and PTZ500 series the OSD menu is accessed by **CALL 57** from a keypad that is connected to the PTZ via RS485 comms. Navigation is done by the **TELE & WIDE** buttons and selection is made with the **NEAR & FAR** buttons.

To exit the OSD menu use **CALL 57** on the keypad.

1.2 The PTZ400 and PTZ600 Series.

When the module is installed in the PTZ400 and PTZ600 series the OSD menu is accessed by **CALL 95** from a keypad that is connected to the PTZ via RS485 comms.

This will enter the menu system of the PTZ. Go to the **CAMERA MENU**, navigation is done by the joystick **UP & DOWN** and selection is made by moving the joystick **RIGHT**. Once in the camera menu go to the **MENU OF CAM** option and move the joystick **RIGHT**. Now you are in the module menu, navigation is done by the **TELE & WIDE** buttons and selection is made with the **NEAR & FAR** buttons.

To exit the OSD menu press the **CLOSE** button on the keypad.

2. The module Menu Structure.

Once in the menu system of the camera module the following submenus are available.

2.1 The FOCUS Menu.

This menu is for configuring the following module settings;

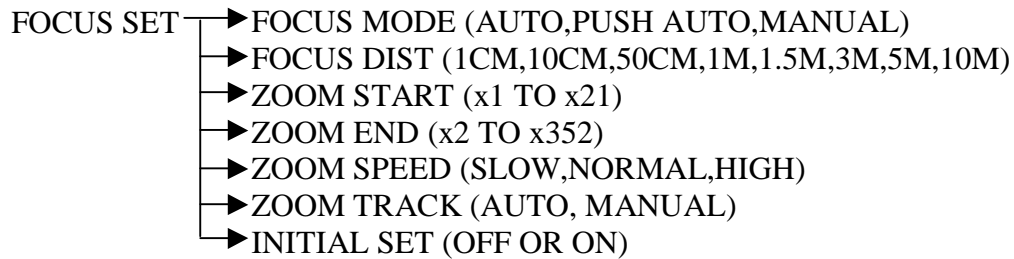

FOCUS MODE Set up of automatic focus option. This allows the user to control the adjustment of the focus automatically by the module (AUTO) or when set to (PUSH AUTO) the camera module will do a single push to focus the camera and will not try to refocus after the initial push or to allow the operator to adjust the focus manually using the NEAR & FAR buttons on the keypad (MANUAL).

FOCAL DISTANCE This option is to set the range of focus distance that the camera will focus to when performing an auto focus. The options are 10m, 5m, 3m, 1m, 1.5m, 50cm, 10cm and 1cm. For example if the focal distance is set to 50cm the module will try to focus within 50cm of the focused object. Note that if a tour or autoscan is used then set distance to 5m or 10m otherwise the unit will not have time to focus.

ZOOM START This option is the setting of the minimum zoom that the module will allow x1 to x21. For example if this is set to x5 the operator will not be able to use the x1 to x4 modes when using the WIDE & TELE buttons.

ZOOM END This option is the setting of the maximum zoom that the module will allow x2 to x352. For example if this is set to x22 the operator will only be able to zoom to the limit of the optical zoom and not the digital zoom up to x352.

ZOOM SPEED This setting is the speed of the modules zoom function.

INITIAL When switched ON this option will reset all of the options within the FOCUS SET menu back to their default setting.

2.2 AWB SET (automatic white balance).

This menu is for configuring the following module settings;

- AWB SET → WB MODE (AUTO,PUSH AUTO,MANUAL,OUTDOOR,INDOOR,HUE CONTROL)
- HUE CONTROL (0 TO 99 WHEN WB MODE IS SET TO HUE CONTROL)
- RED GAIN (0 TO 255 WHEN WB MODE IS SET TO MANUAL)
- BLUE GAIN (0 TO 255 WHEN WB MODE IS SET TO MANUAL)
- PUSH AUTO (OFF OR ON WHEN WB MODE IS SET TO PUSH AUTO)
- INITIAL SET (OFF OR ON)

WB MODE This option is used to instruct the module of the environment in which it is installed and which mode to use to adjust the white balance of the image output. The options are AUTO, PUSH AUTO, MANUAL, INDOOR, OUTDOOR or HUE CONTROL.

HUE CONTROL Hue control is used to alter the definition of the colour on the image from 0 to 99. This can only be used when WB MODE is set to HUE CONTROL.

RED CONT When the WB mode is set to MANUAL this option is used to control the amount of the RED image output by the module. Setting is from 0 (0% red) to 255 (100% red).

BLUE CONT When the WB mode is set to MANUAL this option is used to control the amount of the BLUE image output by the module. Setting is from 0 (0% blue) to 255 (100% blue).

PUSH AUTO Used to select PUSH AUTO mode which will adjust the white balance only once after a PTZ movement. Only used when WB MODE is set to PUSH AUTO.

INITIAL When switched ON this option will reset all of the options within the AWB menu back to their default setting.

2.3 A E SET(automatic exposure).

This menu is for configuring the following module settings;

- AE SET → AE MODE (AUTO,MANUAL,AGC MAN,IRIS MAN)
- IRIS ADJUST (56 TO 250 WHEN AE MODE IS SET TO MANUAL OR IRIS MAN)
- AGC MAXIMUM (28 TO 255)
- BRIGHTNESS (0 TO 99)
- BACKLIGHT (OFF, SUPER, AUTO, ON)
- BLC LEVEL (0 TO 80)
- BLC AREA (CENTER,RIGHT,LEFT,BOTTOML,BOTTOMS,TOPL,TOPS)
- FLICKERLESS (OFF OR ON)
- SHUTTER (NORMAL OR 1/125 TO 1/30000)
- INITIAL SET (OFF OR ON)

- AE MODE** This option is used to select the exposure mode to be used by the camera. The options are AUTO, MANUAL, AGC MAN and IRIS MAN. When the AUTO mode is selected then the module will automatically adjust the iris and automatic gain control (AGC). When in MANUAL the iris and AGC will adjust to the user presets as defined below. When set to AGC MAN the iris control will be done by the module automatically but the AGC will adjust only up to the AGC MAXIMUM level defined below. When set to IRIS MAN the AGC control will be done by the module automatically but the iris will adjust to the IRIS ADJUST defined below.
- IRIS ADJUST** When the AE MODE is set to MANUAL or IRIS MANUAL this is used to open and close the iris manually from 56 to 250.
- AGC MAXIMUM** This option is used to adjust the maximum limit of the automatic gain control (AGC) from 28 to 255, when the AE MODE is set to MANUAL or AGC MAN.
- BRIGHTNESS** This alters the brightness of the image from 0 to 99, where 0 is the darkest and 99 the brightest.
- BACKLIGHT** When there is strong backlight behind the object, clear images of the background and object can still be obtained by using the BACKLIGHT function. The options are OFF, ON, AUTO and SUPER.
- BACKLIGHT AREA** This option lets the camera know the position where the strong backlight is.
- FLICKERLESS** This mode of operation of a camera eliminates flicker, and therefore potential "movement" detected by a camera or DVR. This option turns the FLICKERLESS mode on or off.
- SHUTTER** This option allows the module to run on a slow shutter speed. The options are NORMAL or 1/125 to 1/30000.
- INITIAL** When switched ON this option will reset all of the options within the AE menu back to their default setting.

2.4 SPECIAL SET.

This menu is for configuring the following module settings;

- SPECIAL SET
- ▶ USER TITLE (10 DIGIT ALPHA NUMERIC LABEL)
 - ▶ SHARPNESS (0 TO 15)
 - ▶ MIRROR (OFF, ON)
 - ▶ NEGATIVE (OFF OR ON)
 - ▶ WIDE BURST (OFF OR ON)
 - ▶ INITIAL SET (OFF OR ON)

USER TITLE	A ten digit alpha-numeric label which will appear on the OSD of the camera in the bottom left of the screen.
SHARPNESS	This adjusts the sharpness of the image from 0 (low) to 15 (high).
MIRROR	This option will output a mirror of the image from the module when switched ON.
NEGATIVE	This option will output a negative image when turned ON.
INITIAL	When switched ON this option will reset all of the options within the SPECIAL menu back to their default setting.

2.5 F OSD DISP (On Screen Display).

This menu is for configuring the following module settings;

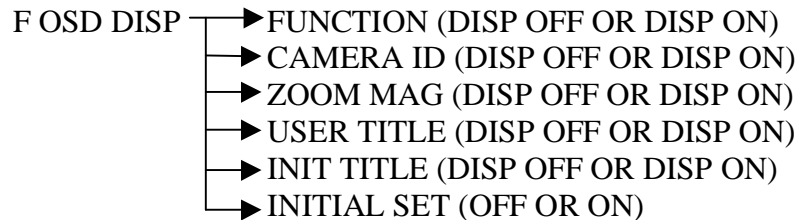

FUNCTION	When this is set to ON the module will overlay the function parameter on the output image.
CAMERA ID	When this is set to ON the module will overlay the camera id on the output image.
ZOOM MAG	When this is set to ON the module will overlay the current zoom magnification on the output image.
USER TITLE	When this is set to ON the module will overlay the USER TITLE (which is set from the SPECIAL menu) on the output image.
INIT TITLE	When this is set to ON the module will overlay the USER TITLE when the PTZ is initialising.
INITIAL	When switched ON this option will reset all of the options within the OSD DISP menu back to their default setting.

2.6 DAY/NIGHT (day and night).

This menu is for configuring the following module settings;

- DAY/NIGHT
 - ▶ D/N MODE (AE,EXT,NIGHT,DAY,SENSOR)
 - ▶ CDS LEVEL (0 TO 255 WHEN D/N MODE IS SET TO SENSOR)
 - ▶ FILTER DELAY (1 TO 15)
 - ▶ INITIAL SET (OFF OR ON)

D & N MODE This option is used to set the module to either switch automatically between day and night mode depending on the level of light available. (AUTO) sets colour during the day and switches to black and white at night. CDS mode will allow the user to define the point at which the module will switch between day and night. DAY makes the module stay in colour mode and NIGHT makes the module stay in black and white mode.

CDS LEVEL Cadmium Sulphide (CdS) cells rely on the materials ability to vary its resistance according to the amount of light striking the cell. The CdS level from 0 to 255, will alter the point of which the module switches between day and night mode when the D & N mode is set to SENSOR.

FILTER DELAY This setting allows you to determine the time delay of the switch over from day to night mode, or night to day mode, once the switching point has been reached. 1 to 15 seconds.

INITIAL When switched ON this option will reset all of the options within the D & N menu back to their default setting.

2.7 INITIAL.

INITIAL SET This menu is for resetting the module back to the factory default settings by turning this setting ON.

**The new 27x NitePlus PTZ module for
the Pan, Tilt and Zoom ranges of domes.**

Camera Instruction Manual.

Superior Auto Focus

Superior Backlight Compensation



1. OSD Navigation.

The way to navigate to the menu options is dependant on the model of PTZ that the module has been installed in.

1.1 The PTZ300 and PTZ500 Series.

When the module is installed in the PTZ300 and PTZ500 series the OSD menu is accessed by **CALL 57** from a keypad that is connected to the PTZ via RS485 comms. Navigation is done by the **TELE & WIDE** buttons and selection is made with the **NEAR & FAR** buttons.

To exit the OSD menu use **CALL 57** on the keypad.

1.2 The PTZ400 and PTZ600 Series.

When the module is installed in the PTZ400 and PTZ600 series the OSD menu is accessed by **CALL 63** from a keypad that is connected to the PTZ via RS485 comms.

This will enter the **CAMERA MODULE MENU** and navigation is done by the **TELE & WIDE** buttons and selection is made with the **NEAR & FAR** buttons.

To exit the menu press the **EXIT** button on the keypad.

NOTE: If using the PTZ700 keypad it will be necessary to enter the 63 CALL twice.

2. The module Menu Structure.

Once in the menu system of the camera module the following submenus are available.

2.1 The GENERAL Menu.

This menu is for configuring the following module settings;

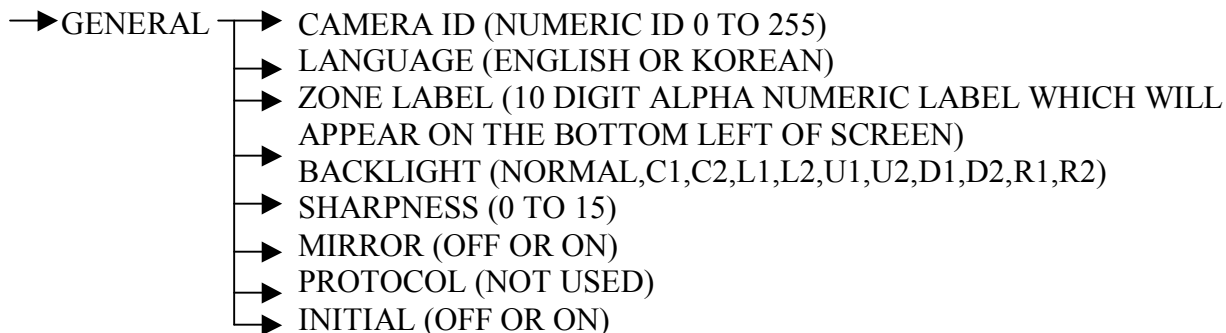

CAMERA ID	A numeric identifying number between 0 and 255.
LANGUAGE	English or Korean.
ZONE LABEL	A ten digit alpha-numeric label which will appear on the OSD of the camera in the bottom left of the screen.
BACKLIGHT	Used to switch backlight compensation on or off. This can be used to improve image quality when the object viewed is dark or dim. This option allows the user to increase backlight compensation in the area in which the problem is occurring either the centre (C1,C2) the left (L1,L2) the right (R1,R2) the upper (U1,U2) the lower (D1,D2) or normal.
SHARPNESS	This adjusts the sharpness of the image from 0 (low) to 15 (high).
MIRROR	This option flips when ON changes the output of the image as if seen through a mirror.
PROTOCOL	Not used.
INITIAL	When switched ON this option will reset all of the options within the GENERAL menu back to their default setting.

2.2 The FOCUS menu.

This menu is for configuring the following module settings;

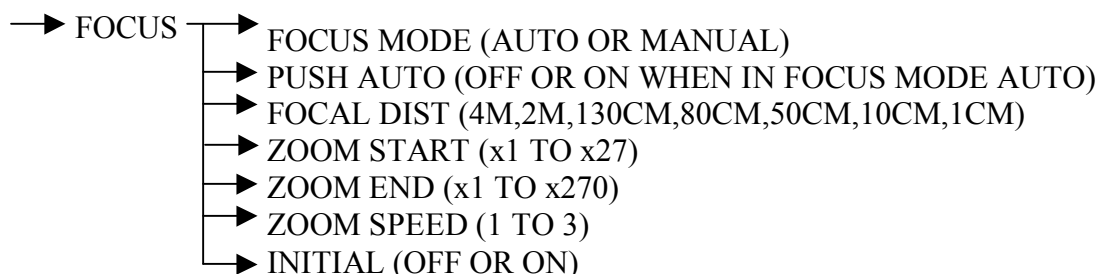

FOCUS MODE Set up of automatic focus option. This allows the user to control the adjustment of the focus automatically by the module (AUTO) or to allow the operator to adjust the focus manually using the NEAR & FAR buttons on the keypad (MANUAL).

PUSH AUTO When set to ON the camera module will do a single push to focus the camera and will not try to refocus after the initial push (n.b. FOCUS mode must be set to auto to enable this option).

FOCAL DISTANCE This option is to set the range of focus distance that the camera will focus to when performing an auto focus. The options are 4m, 2m, 130cm, 80cm, 50cm, 10cm and 1cm. For example if the focal distance is set to 50cm the module will try to focus within 50cm of the focused object.

ZOOM START This option is the setting of the minimum zoom that the module will allow x1 to x27. For example if this is set to x5 the operator will not be able to use the x1 to x4 modes when using the WIDE & TELE buttons.

ZOOM END This option is the setting of the maximum zoom that the module will allow x1 to x270. For example if this is set to x27 the operator will only be able to zoom to the limit of the optical zoom and not the digital zoom up to x270.

ZOOM SPEED This setting is the speed of the modules zoom function 1 to 3 with 1 being the slowest and 3 the fastest.

INITIAL When switched ON this option will reset all of the options within the FOCUS menu back to their default setting.

2.3 AWB (automatic white balance).

This menu is for configuring the following module settings;

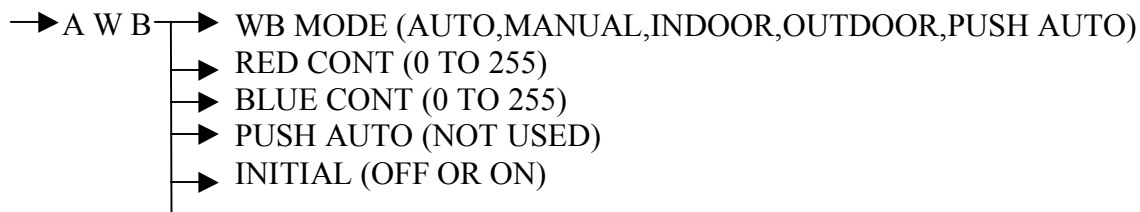

WB MODE This option is used to instruct the module of the environment in which it is installed and which mode to use to adjust the white balance of the image output. The options are AUTO, MANUAL, INDOOR, OUTDOOR or PUSH AUTO.

RED CONT When the WB mode is set to MANUAL this option is used to control the amount of the RED image output by the module. Setting is from 0 (0% red) to 255 (100% red).

BLUE CONT When the WB mode is set to MANUAL this option is used to control the amount of the BLUE image output by the module. Setting is from 0 (0% blue) to 255 (100% blue).

PUSH AUTO Not used.

INITIAL When switched ON this option will reset all of the options within the AWB menu back to their default setting.

2.4 A E (automatic exposure).

This menu is for configuring the following module settings;

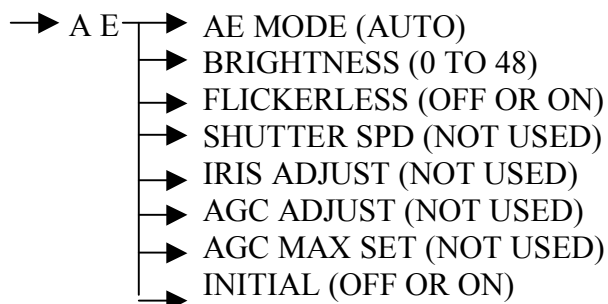

AE MODE	Always set to AUTO.
BRIGHTNESS	This alters the brightness of the image output by the module from 0 to 48, where 0 is the darkest and 48 the brightest.
FLICKERLESS	This setting turns the flickerless mode ON or OFF.
SHUTTER SPEED	Not used.
IRIS ADJUST	Not used.
AGC ADJUST	Not used.
AGC MAX SET	Not used.
INITIAL	When switched ON this option will reset all of the options within the AE menu back to their default setting.

2.5 D & N (day and night).

This menu is for configuring the following module settings;

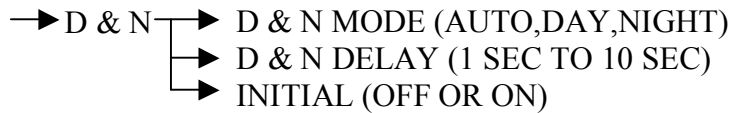

D & N MODE This option is used to set the module to either switch automatically between day and night mode depending on the level of light available. (AUTO) sets colour during the day and switches to black and white at night, (DAY) stays in colour and (NIGHT) stays in black and white.

D & N DELAY This setting allows you to determine the time delay of the switch over from day to night mode, or night to day mode, once the switching point has been reached. 1 to 10 seconds.

INITIAL When switched ON this option will reset all of the options within the D & N menu back to their default setting.

2.6 SLOW SHT (slow shutter).

This menu is for configuring the following module settings;

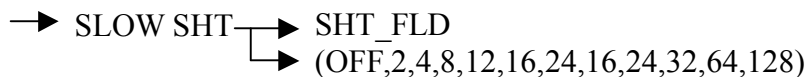

SHT_FLD This setting allows the module to slow the shutter speed down or to turn the slow shutter off. The range of shutter speeds range from 2 to 128.

INITIAL When switched ON this option will reset all of the options within the SLOW SHT menu back to their default setting.

2.7 MOTION (motion detection).

This menu is for configuring the following module settings;

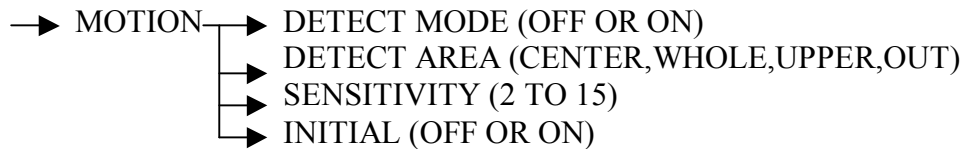

DETECT MODE This option turns the motion detection system ON or OFF. When this system is turned on, the module will display the text MD on the screen when motion detection is triggered.

DETECT AREA This setting determines which area of the image to trigger the motion detection system on. For example if set to UPPER the module will trigger only if movement is detected in the upper area of the image. Options are CENTER, WHOLE, UPPER and OUTER.

SENSITIVITY This setting determines the sensitivity of the trigger of the motion detection system, with 2 being the lowest and 15 being the highest sensitivity.

INITIAL When switched ON this option will reset all of the options within the MOTION menu back to their default setting.

2.8 DISPLAY.

This menu is for configuring the following module settings;

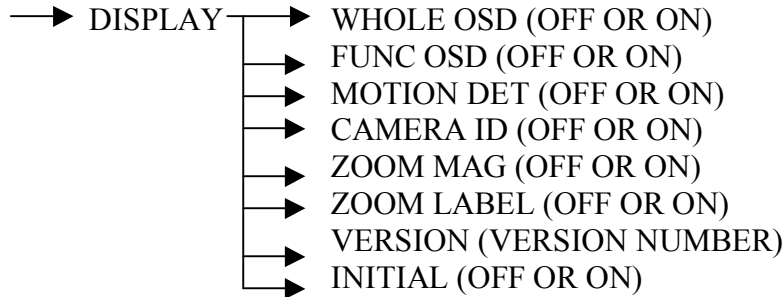

WHOLE OSD	When this is set to ON the module will overlay all of the parameters listed below on to the output image.
FUNC OSD	When this is set to ON the module will overlay the function parameter on the output image.
MOTION DET	When this is set to ON the module will overlay the motion detected on the output image if the motion detection system is triggered.
CAMERA ID	When this is set to ON the module will overlay the camera id (which is set from the GENERAL menu) on the output image.
ZOOM MAG	When this is set to ON the module will overlay the current zoom magnification on the output image.
VERSION	This is a display of the firmware version the module is using.
INITIAL	When switched ON this option will reset all of the options within the DISPLAY menu back to their default setting.

2.9 INITIAL.

INITIAL SET This menu is for resetting the module back to the factory default settings by turning this setting ON.

Technical Specifications

Signal System	PAL
Scanning System	2:1 Interface
Scanning Frequency (H)	15.625kHz
Scanning Frequency (V)	50Hz
Image Sensor	1/4" Sony Super HAD CCD
Sync. System	Internal
Total Pixels	795(H) x 596(V) 470K
Effective Pixels	752(H) x 582(V) 440K
Horizontal Resolution	500TVL
Video Output Level	1.0v p~p (75Ω, Composite)
S/N Ratio	More than 48dB (AGC Off)
Digital Zoom Ratio	10 x
Lens	27 x zoom Video AF (F1.6(W), F3.2(T) f=3.6 ~ 97.2mm)
Minimum Illumination	Day Mode 1 Lux (30IRE) Night Mode 0.5 Lux (30IRE) DSS 0.001 Lux (128FLD, 30IRE)
Day & Night System	IR Cut Filter & Digital Slow Shutter
White Balance	Auto/Push Auto/Outdoor/Indoor/Special
AGC	Auto/Manual (0~255)
Backlight Compensation	9 Backlight Compensation Zones
Flickerless	On/Off
Digital Slow Shutter	2 FLD ~ 128 FLD / Off
OSD Menu	On / Off
Focus Mode	Auto / Manual
Input Output Connections	Power: 2 Pin Terminal RS485: 2 Pin Circle Connector PTZ Control: 3 Pin Circle Connector Video Output: BNC Connector
Electronic Shutter Speed	1/50 ~ 1/10,000s (Manual, 8 steps)
Supplied Voltage	12v DC
Power Consumption	Max 4.56W / 380mA
Dimensions	48(W) x 51.5 (H) x 86.6 (D) mm
Weight (Net)	Approximately 250g

**The new NitePlus PTZ module for the
Pan, Tilt and Zoom ranges of domes.**

Camera Instruction Manual.



1. OSD Navigation.

The way to navigate to the menu options is dependant on the model of PTZ that the module has been installed in.

1.1 The PTZ300 and PTZ500 Series.

When the module is installed in the PTZ300 and PTZ500 series the OSD menu is accessed by **CALL 57** from a keypad that is connected to the PTZ via RS485 comms. Navigation is done by the **TELE & WIDE** buttons and selection is made with the **NEAR & FAR** buttons.

To exit the OSD menu use **CALL 57** on the keypad.

1.2 The PTZ400 and PTZ600 Series.

When the module is installed in the PTZ400 and PTZ600 series the OSD menu is accessed by **CALL 63** from a keypad that is connected to the PTZ via RS485 comms.

This will enter the **CAMERA MODULE MENU** and navigation is done by the **TELE & WIDE** buttons and selection is made with the **NEAR & FAR** buttons.

To exit the menu press the **EXIT** button on the keypad.

2. The module Menu Structure.

Once in the menu system of the camera module the following submenus are available.

2.1 The GENERAL Menu.

This menu is for configuring the following module settings;

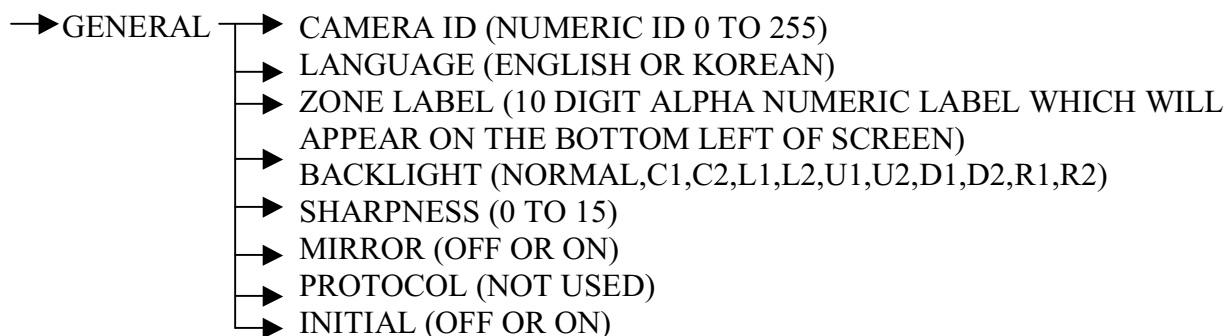

CAMERA ID	A numeric identifying number between 0 and 255.
LANGUAGE	English or Korean.
ZONE LABEL	A ten digit alpha-numeric label which will appear on the OSD of the camera in the bottom left of the screen.
BACKLIGHT	Used to switch backlight compensation on or off. This can be used to improve image quality when the object viewed is dark or dim. This option allows the user to increase backlight compensation in the area in which the problem is occurring either the centre (C1,C2) the left (L1,L2) the right (R1,R2) the upper (U1,U2) the lower (D1,D2) or normal.
SHARPNESS	This adjusts the sharpness of the image from 0 (low) to 15 (high).
MIRROR	This option flips when ON changes the output of the image as if seen through a mirror.
PROTOCOL	Not used.
INITIAL	When switched ON this option will reset all of the options within the GENERAL menu back to their default setting.

2.2 The FOCUS menu.

This menu is for configuring the following module settings;

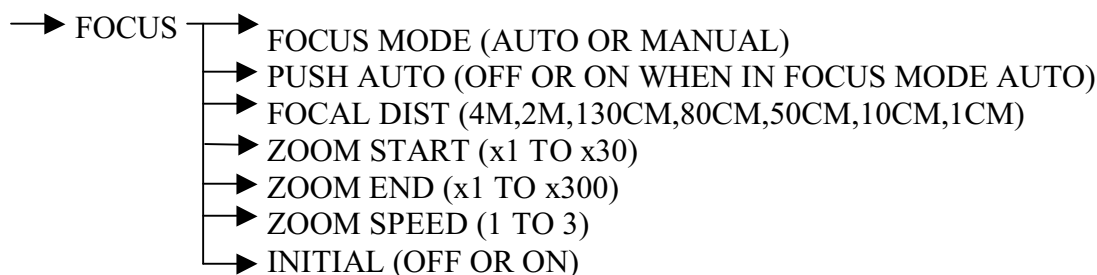

FOCUS MODE	Set up of automatic focus option. This allows the user to control the adjustment of the focus automatically by the module (AUTO) or to allow the operator to adjust the focus manually using the NEAR & FAR buttons on the keypad (MANUAL).
PUSH AUTO	When set to ON the camera module will do a single push to focus the camera and will not try to refocus after the initial push (n.b. FOCUS mode must be set to auto to enable this option).
FOCAL DISTANCE	This option is to set the range of focus distance that the camera will focus to when performing an auto focus. The options are 4m, 2m, 130cm, 80cm, 50cm, 10cm and 1cm. For example if the focal distance is set to 50cm the module will try to focus within 50cm of the focused object.
ZOOM START	This option is the setting of the minimum zoom that the module will allow x1 to x30. For example if this is set to x5 the operator will not be able to use the x1 to x4 modes when using the WIDE & TELE buttons.
ZOOM END	This option is the setting of the maximum zoom that the module will allow x1 to x300. For example if this is set to x30 the operator will only be able to zoom to the limit of the optical zoom and not the digital zoom up to x300.
ZOOM SPEED	This setting is the speed of the modules zoom function 1 to 3 with 1 being the slowest and 3 the fastest.
INITIAL	When switched ON this option will reset all of the options within the FOCUS menu back to their default setting.

2.3 AWB (automatic white balance).

This menu is for configuring the following module settings;

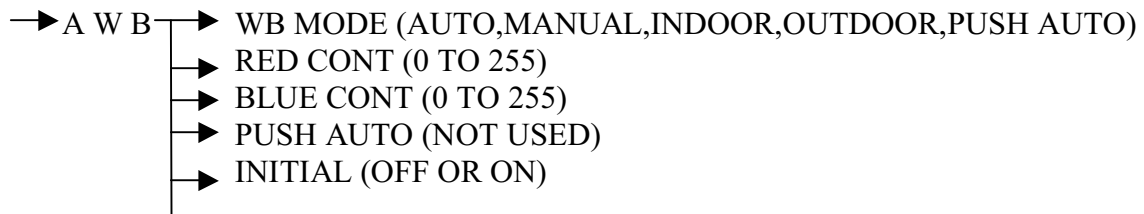

WB MODE This option is used to instruct the module of the environment in which it is installed and which mode to use to adjust the white balance of the image output. The options are AUTO, MANUAL, INDOOR, OUTDOOR or PUSH AUTO.

RED CONT When the WB mode is set to MANUAL this option is used to control the amount of the RED image output by the module. Setting is from 0 (0% red) to 255 (100% red).

BLUE CONT When the WB mode is set to MANUAL this option is used to control the amount of the BLUE image output by the module. Setting is from 0 (0% blue) to 255 (100% blue).

PUSH AUTO Not used.

INITIAL When switched ON this option will reset all of the options within the AWB menu back to their default setting.

2.4 A E (automatic exposure).

This menu is for configuring the following module settings;

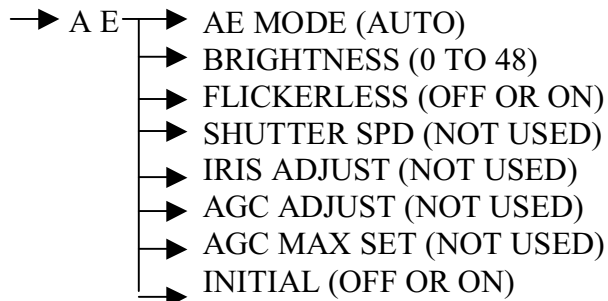

AE MODE	Always set to AUTO.
BRIGHTNESS	This alters the brightness of the image output by the module from 0 to 48, where 0 is the darkest and 48 the brightest.
FLICKERLESS	This setting turns the flickerless mode ON or OFF.
SHUTTER SPEED	Not used.
IRIS ADJUST	Not used.
AGC ADJUST	Not used.
AGC MAX SET	Not used.
INITIAL	When switched ON this option will reset all of the options within the AE menu back to their default setting.

2.5 D & N (day and night).

This menu is for configuring the following module settings;

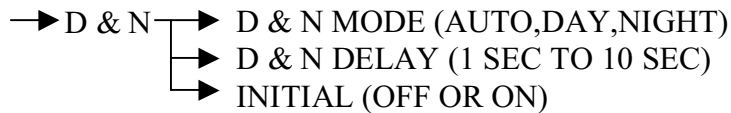

D & N MODE This option is used to set the module to either switch automatically between day and night mode depending on the level of light available. (AUTO) sets colour during the day and switches to black and white at night, (DAY) stays in colour and (NIGHT) stays in black and white.

D & N DELAY This setting allows you to determine the time delay of the switch over from day to night mode, or night to day mode, once the switching point has been reached. 1 to 10 seconds.

INITIAL When switched ON this option will reset all of the options within the D & N menu back to their default setting.

2.6 SLOW SHT (slow shutter).

This menu is for configuring the following module settings;

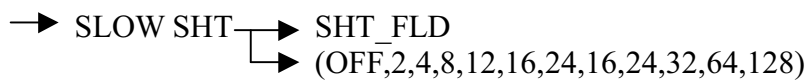

SHT_FLD This setting allows the module to slow the shutter speed down or to turn the slow shutter off. The range of shutter speeds range from 2 to 128.

INITIAL When switched ON this option will reset all of the options within the SLOW SHT menu back to their default setting.

2.7 MOTION (motion detection).

This menu is for configuring the following module settings;

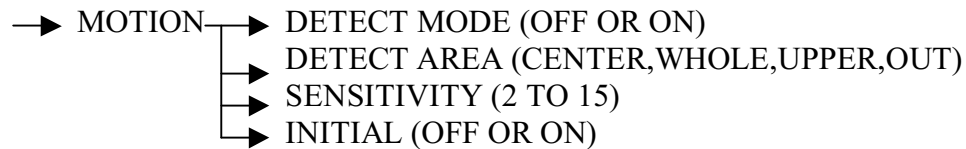

DETECT MODE This option turns the motion detection system ON or OFF. When this system is turned on, the module will display the text MD on the screen when motion detection is triggered.

DETECT AREA This setting determines which area of the image to trigger the motion detection system on. For example if set to UPPER the module will trigger only if movement is detected in the upper area of the image. Options are CENTER, WHOLE, UPPER and OUTER.

SENSITIVITY This setting determines the sensitivity of the trigger of the motion detection system, with 2 being the lowest and 15 being the highest sensitivity.

INITIAL When switched ON this option will reset all of the options within the MOTION menu back to their default setting.

2.8 DISPLAY.

This menu is for configuring the following module settings;

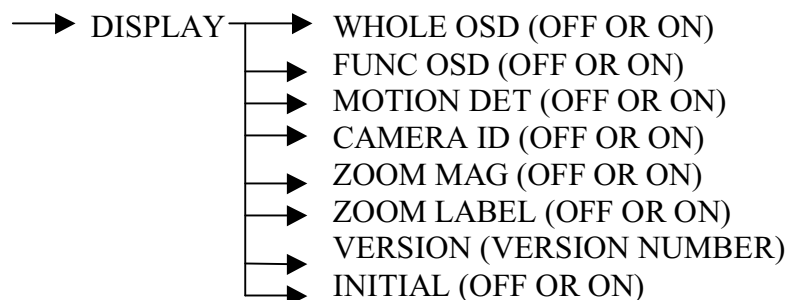

WHOLE OSD	When this is set to ON the module will overlay all of the parameters listed below on to the output image.
FUNC OSD	When this is set to ON the module will overlay the function parameter on the output image.
MOTION DET	When this is set to ON the module will overlay the motion detected on the output image if the motion detection system is triggered.
CAMERA ID	When this is set to ON the module will overlay the camera id (which is set from the GENERAL menu) on the output image.
ZOOM MAG	When this is set to ON the module will overlay the current zoom magnification on the output image.
VERSION	This is a display of the firmware version the module is using.
INITIAL	When switched ON this option will reset all of the options within the DISPLAY menu back to their default setting.

2.9 INITIAL.

INITIAL SET	This menu is for resetting the module back to the factory default settings by turning this setting ON.
-------------	--

The 35x PTZ module for the Pan, Tilt and Zoom ranges of domes.

Camera Instruction Manual.



1. OSD Navigation.

The way to navigate to the menu options is dependant on the model of PTZ that the module has been installed in.

1.1 The PTZ300 and PTZ500 Series.

When the module is installed in the PTZ300 and PTZ500 series the OSD menu is accessed by **CALL 57** from a keypad that is connected to the PTZ via RS485 comms. Navigation is done by the **TELE & WIDE** buttons and selection is made with the **NEAR & FAR** buttons.

To exit the OSD menu use **CALL 57** on the keypad.

1.2 The PTZ400 and PTZ600 Series.

When the module is installed in the PTZ400 and PTZ600 series the OSD menu is accessed by **CALL 95** from a keypad that is connected to the PTZ via RS485 comms.

This will enter the menu system of the PTZ. Go to the **CAMERA MENU**, navigation is done by the joystick **UP & DOWN** and selection is made by moving the joystick **RIGHT**. Once in the camera menu go to the **MENU OF CAM** option and move the joystick **RIGHT**. Now you are in the module menu, navigation is done by the **TELE & WIDE** buttons and selection is made with the **NEAR & FAR** buttons.

To exit the OSD menu press the **CLOSE** button on the keypad.

2. The module Menu Structure.

Once in the menu system of the camera module the following submenus are available.

2.1 The FOCUS Menu.

This menu is for configuring the following module settings;

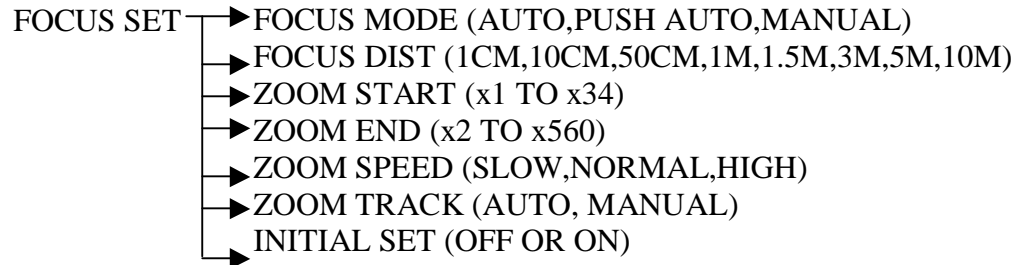

FOCUS MODE Set up of automatic focus option. This allows the user to control the adjustment of the focus automatically by the module (AUTO) or when set to (PUSH AUTO) the camera module will do a single push to focus the camera and will not try to refocus after the initial push or to allow the operator to adjust the focus manually using the NEAR & FAR buttons on the keypad (MANUAL).

FOCAL DISTANCE This option is to set the range of focus distance that the camera will focus to when performing an auto focus. The options are 10m, 5m, 3m, 1m, 1.5m, 50cm, 10cm and 1cm. For example if the focal distance is set to 50cm the module will try to focus within 50cm of the focused object. Note that if a tour or autoscan is used then set distance to 5m or 10m otherwise the unit will not have time to focus.

ZOOM START This option is the setting of the minimum zoom that the module will allow x1 to x34. For example if this is set to x5 the operator will not be able to use the x1 to x4 modes when using the WIDE & TELE buttons.

ZOOM END This option is the setting of the maximum zoom that the module will allow x2 to x560. For example if this is set to x35 the operator will only be able to zoom to the limit of the optical zoom and not the digital zoom up to x560.

ZOOM SPEED This setting is the speed of the modules zoom function.

INITIAL When switched ON this option will reset all of the options within the FOCUS SET menu back to their default setting.

2.2 AWB SET (automatic white balance).

This menu is for configuring the following module settings;

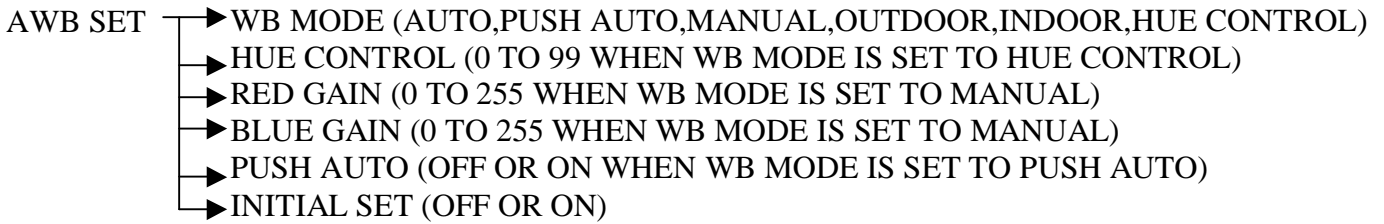

WB MODE This option is used to instruct the module of the environment in which it is installed and which mode to use to adjust the white balance of the image output. The options are AUTO, PUSH AUTO, MANUAL, INDOOR, OUTDOOR or HUE CONTROL.

HUE CONTROL Hue control is used to alter the definition of the colour on the image from 0 to 99. This can only be used when WB MODE is set to HUE CONTROL.

RED CONT When the WB mode is set to MANUAL this option is used to control the amount of the RED image output by the module. Setting is from 0 (0% red) to 255 (100% red).

BLUE CONT When the WB mode is set to MANUAL this option is used to control the amount of the BLUE image output by the module. Setting is from 0 (0% blue) to 255 (100% blue).

PUSH AUTO Used to select PUSH AUTO mode which will adjust the white balance only once after a ptz movement. Only used when WB MODE is set to PUSH AUTO.

INITIAL When switched ON this option will reset all of the options within the AWB menu back to their default setting.

2.3 A E SET(automatic exposure).

This menu is for configuring the following module settings;

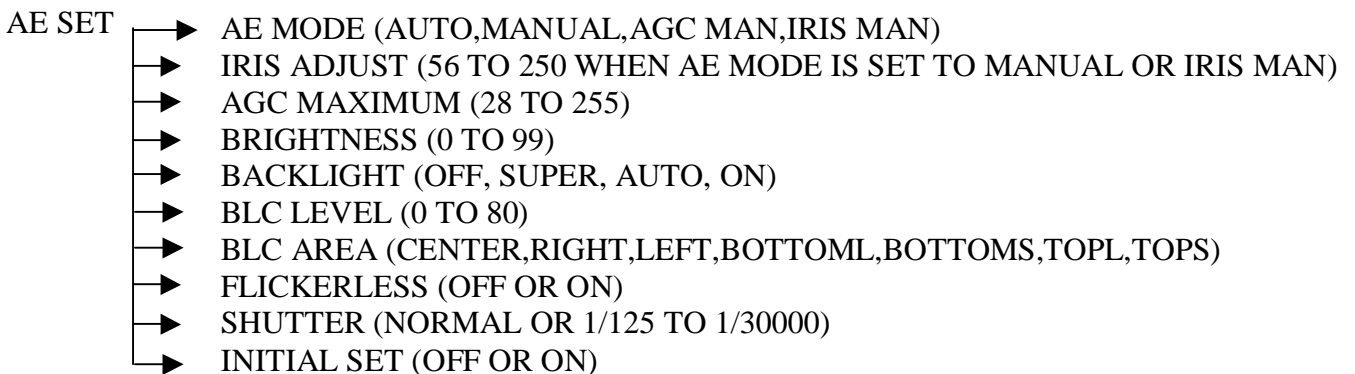

- AE MODE** This option is used to select the exposure mode to be used by the camera. The options are AUTO, MANUAL, AGC MAN and IRIS MAN. When the AUTO mode is selected the module will automatically adjust the iris and automatic gain control (AGC). When in MANUAL mode the iris and AGC will adjust to the user presets as defined below. When set to AGC MAN the iris control will be done by the module automatically but the AGC will adjust only up to the AGC MAXIMUM level defined below. When set to IRIS MAN the AGC control will be done by the module automatically but the iris will adjust to the IRIS ADJUST defined below.
- IRIS ADJUST** When the AE MODE is set to MANUAL or IRIS MANUAL this is used to open and close the iris manually from 56 to 250.
- AGC MAXIMUM** This option is used to adjust the maximum limit of the automatic gain control (AGC) from 28 to 255, when the AE MODE is set to MANUAL or AGC MAN.
- BRIGHTNESS** This alters the brightness of the image from 0 to 99, where 0 is the darkest and 99 the brightest.
- BACKLIGHT** When there is strong backlight behind the object, clear images of the background and object can still be obtained by using the BACKLIGHT function. The options are OFF, ON, AUTO and SUPER.
- BACKLIGHT AREA** This option lets the camera know the position where the strong backlight is.
- FLICKERLESS** This mode of operation of a camera eliminates flicker, and therefore potential "movement" detected by a camera or DVR. This option turns the FLICKERLESS mode on or off.
- SHUTTER** This option allows the module to run on a slow shutter speed. The options are NORMAL or 1/125 to 1/30000.
- INITIAL** When switched ON this option will reset all of the options within the AE menu, back to their default setting.

2.4 SPECIAL SET.

This menu is for configuring the following module settings;

- SPECIAL SET → USER TITLE (10 DIGIT ALPHA NUMERIC LABEL)
- SHARPNESS (0 TO 15)
- MIRROR (OFF, ON)
- NEGATIVE (OFF OR ON)
- WIDE BURST (OFF OR ON)
- INITIAL SET (OFF OR ON)

USER TITLE	A ten digit alpha-numeric label which will appear on the OSD of the camera in the bottom left of the screen.
SHARPNESS	This adjusts the sharpness of the image from 0 (low) to 15 (high).
MIRROR	This option will output a mirror of the image from the module when switched ON.
NEGATIVE	This option will output a negative image when turned ON.
INITIAL	When switched ON this option will reset all of the options within the SPECIAL menu back to their default setting.

2.5 F OSD DISP (On Screen Display).

This menu is for configuring the following module settings;

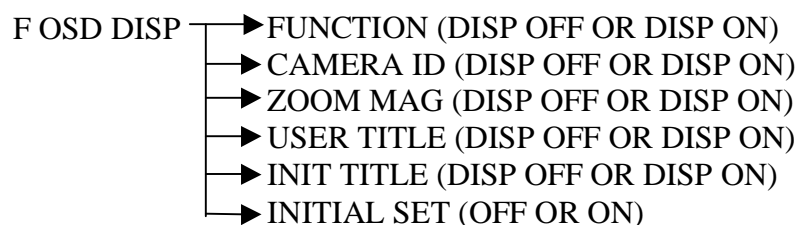

FUNCTION	When this is set to ON the module will overlay the function parameter on the output image.
CAMERA ID	When this is set to ON the module will overlay the camera id on the output image.
ZOOM MAG	When this is set to ON the module will overlay the current zoom magnification on the output image.
USER TITLE	When this is set to ON the module will overlay the USER TITLE (which is set from the SPECIAL menu) on the output image.
INIT TITLE	When this is set to ON the module will overlay the USER TITLE when the PTZ is initialising.
INITIAL	When switched ON this option will reset all of the options within the OSD DISP menu back to their default setting.

2.6 DAY/NIGHT (day and night).

This menu is for configuring the following module settings;

DAY/NIGHT

- D/N MODE (AE,EXT,NIGHT,DAY,SENSOR)
- CDS LEVEL (0 TO 255 WHEN D/N MODE IS SET TO SENSOR)
- FILTER DELAY (1 TO 15)
- INITIAL SET (OFF OR ON)

D & N MODE This option is used to set the module to either switch automatically between day and night mode depending on the level of light available. (AUTO) sets colour during the day and switches to black and white at night. CDS mode will allow the user to define the point at which the module will switch between day and night. DAY makes the module stay in colour mode and NIGHT makes the module stay in black and white mode.

CDS LEVEL Cadmium Sulphide (CdS) cells rely on the materials ability to vary its resistance according to the amount of light striking the cell. The CdS level from 0 to 255, will alter the point of which the module switches between day and night mode when the D & N mode is set to SENSOR.

FILTER DELAY This setting allows you to determine the time delay of the switch-over from day to night mode, or night to day mode, once the switching point has been reached. 1 to 15 seconds.

INITIAL When switched ON this option will reset all of the options within the D & N menu back to their default setting.

2.7 INITIAL.

INITIAL SET This menu is for resetting the module back to the factory default settings by turning this setting ON.