

Armoured PTZ range

Installation and Operation Manual

Outdoor *HIGH* Speed Armoured Pan Tilt Zoom 12V DC model with Infrared Camera

Models Covered
PTZ905



Version 1.0

CONTENTS TABLE

Description	Page No.
Contents	2
Safety Precautions	3
Key Functions	4
Special PTZ Features	5
Getting the PTZ up & running	6
Overview – introduction to fitting PTZ equipment	6
RS485 Wiring methods & Tips	8
Overcoming RS485 data loss using an RS485 distributor	11
Setting up the PTZ Camera	13
RS485 connection – Connecting the Keypad or DVR to the PTZ905	14
Connecting the video out of the PTZ	16
If you are using more than one PTZ on a site	18
Setting up a unique address in the PTZ905	18
Setup of the Protocol and the Default Baud Rate	19
Using the CCT786 and CCT768 keypad with the PTZ905	21
Presets and other functions	22
Patrols (Tours) – How to set them up and use them	23
Auto Scan – How to set it up – Calling the Auto Scan	26
Record Pattern – What is a record pattern?	27
What is the difference between a pattern & a patrol (tour) ?	27
How to set it up – Running the Record Pattern	27
Using the PTZ's Advanced Functions	29
Using the Advanced Menu System	30
Display Setup	31
Camera Setup	33
Control Setup	35
Program	37
PAL/NTSC Camera	39
CAM Default Set	40
Reset PT	41
Exit	42
Controlling one camera then another	42
Installation Instructions	43
Installation Steps	44
Technical Data Table	46
Appendix A: Lightning Proof and Surge Signal Proof	47

Please read this operation manual carefully
before installing and using this unit !!!!



Please read the following;

1. Please read the operation manual carefully before installing and operating the product.
2. **The PTZ905 requires a 12 V DC power supply.** The rated input voltage of the camera is 12V!!!! This gets its power from the PTZ905 and does not require a separate PSU. **Do not connect 24V AC to this PTZ under any circumstances!!**
3. During the course of transportation, storage and installation, the product should be handled with care avoiding vibration and any weight pressure, which may cause damage to the sophisticated optical and electronic equipment inside the machine.
4. Do not attempt to disassemble the camera. In order to prevent electric shock, do not remove screws or covers. There are no user-serviceable parts inside the camera.
5. Always use and stick to current electrical safety standards to install and use the PTZ905. Use a correctly rated power supply. The RS-485 and video signal cables should be kept way from other high voltage equipment such as mains cables and especially fluorescent lights. Using an anti surge protection device is recommended to prevent damage to the PTZ905 from lightning and mains surges. Damage to units by lightning or mains voltage surges is not covered under the product warranty.
6. Do not operate in areas exceeding the stipulated limitations concerning temperature, humidity and power supply.
7. Do not aim the camera directly towards the sun or an extreme light source whether it is switched on or not. Do not let the camera focus on bright and stationery objects for a long time. Doing either of these may damage the camera.
8. Do not use strong detergents to clean the main body of the camera as these may damage the PTZ paintwork. Wipe dirt with dry cloth. If needed a *mild* detergent can be used.
9. Operate the PTZ camera with care avoiding shock or vibration. If operated incorrectly, the PTZ could be damaged.
10. Ensure the PTZ is not dropped. The PTZ905 weighs approximately 10Kgs so never mount the unit on a structure that cannot support its weight.
11. When this unit is in use, avoid direct eye contact with the infrared lights.
12. The unit's outer case can heat up to 55°C when in use and care should be taken to ensure that this PTZ is fitted where it cannot be easily touched. It must also not be fitted in close proximity of any flammable materials.

KEY FUNCTIONS

The Armoured PTZ905 -

II. Description of Functions

This intelligent armoured PTZ is a hi-tech CCTV product, which incorporates a high-clarity colour camera. It has a panoramic variable speed PAN/TILT movement, a multifunctional decoder, a character generator and an on-board processor for logic handling. The PTZ905 is easy to connect, install, maintain and operate, and has many special features. Its unique design and shape offers a more obvious deterrent with its infrared capability and robust construction. The PTZ905 has more vandal resistant features than a standard PTZ dome and is a good choice for both indoor and external surveillance.

1. Integrated Multi-Protocol Decoder

- a. The integrated multifunctional decoder can communicate with 16 different protocols. The baud rate can be independently set allowing compatibility with numerous systems with selectable baud rates from 2400 bps to 19200 bps. Dip switches control the selection of the protocol and baud rate thus making this PTZ easy to set up and use.
- b. The PTZ905 uses RS485 serial control with address ranges between 1 and 1023 using binary dipswitch settings.

2. Integrated Speed-Variable PAN/TILT

- a. The PTZ can turn 360° horizontally and continuously with unlimited positions with an adjustable speed from 0.9 - 60rad/s and turning 0 - 90° vertically with a speed up to 40 rad/s.
- b. The PTZ can run at low speed, low noise, and does not show any picture shake.
- c. The PTZ905 is a high precision unit and maintains preset positions up to $\pm 0.1^\circ$.

3. High Intelligent Settings

- a. This PTZ can store up to 128 preset positions in non-volatile memory that are not lost with a power failure. Refer to the section "Presets and other functions."
- b. The PTZ can scan horizontally between two points and the scan speed can be modified. The PTZ can scan a range larger or smaller than 180° between any two points with adjustable speed settings. Refer to the section on "Auto Scan."
- c. Six sets of tours (patrols) each with 16 preset positions can be programmed. The running speed and the dwell times are adjustable. Refer to the section on "Patrols (Tours)."
- d. The PTZ camera can simulate a route operated by you within a 40 second interval by utilising the Record Pattern facility. Refer to the section on "Record Pattern."
- d. The logical structure of the menu makes all setups and programming of the PTZ camera more convenient and easy to operate.
- e. Long focus speed-limited function. The PTZ can automatically adjust the manual control speed to ensure rapid and accurate target searching. The larger the magnification, the slower the manual control speed.

4. Functions of the Camera (when the OSD option of the camera is ON)

- a. **Focus Control Mode:** the user can manually adjust the focal length of the camera.
- b. **Magnification Control:** the user can adjust the lens to control magnification.

-
- c. **Backlight Compensation:** When the object to be shot has a dark background, the user can increase the backlight compensation accordingly.
 - d. **White Balance:** If the image has incorrect colours displayed on the monitor, the user can use different modes to alter the white balance. There are 6 modes for selection: Indoor Mode, Outdoor Mode, Trigger Mode, Auto tracking White Balance, Manual White Balance and Automatic Mode.
 - e. **AE Mode:** Manual/Automatic Setup.
 - f. **Low Illumination Setup:** The camera will normally operate under normal conditions but when the ambient light level drops below 1 Lux the camera can automatically switch into low illumination state. This setting can also be made manually.
 - g. **Other functions:** Other functions are available according to the camera fitted. Use the system menu to access these functions.

5. Special PTZ Features

Infrared System

The infrared system runs normally under automatic control. The Infrared lamps illuminate in a low light condition and switch off when light levels improve. A menu default option is set to OFF for normal operation. The user may set the option to ON to force the Infrareds to illuminate but if it is required to return to normal mode the option must be set to OFF.

Note: To stop the PTZ from oscillating between infrared illumination on and off during low light conditions, the PTZ is automatically set to keep the infrared illumination on for 30 minutes once it has been triggered.

Special Note: The PTZ905 does not have Alarm Inputs/Output as available on the PTZ900 24V AC model.

Vehicle and Portable Applications

The PTZ905 can be fitted to vehicles and used in portable applications. It is recommended that the unit is fitted with the PTZ910 rubber shock absorber when subject to vibration.

Getting the PTZ up and running!



You **MUST** connect up the PTZ and your control equipment on a workbench or kitchen table before the actual site installation and **CHECK YOU KNOW HOW TO INSTALL IT CORRECTLY!!!!!!!!!!!!!!!!!!!!!!**.

By doing this you can set-up any DIP switches, adjust the camera, and learn about how it operates before taking it to site. This will save you hours of time on-site trying to work out why a particular item doesn't function as you expected it to. There is nothing worse than installing something and then having to take it down to see how to get it working!! Do the learning curve in the comfort of your own premises!!!!

Do you KNOW how to install PTZ equipment that is controlled by RS485 data signals?

If not please read the following introduction to PTZ >>>....

Overview- introduction to fitting PTZ equipment

Generally speaking, PTZs require four things;

- 1- They require a power supply and a cable to supply this power to the PTZ. The PTZ905 operates on 12V DC.
- 2- They require a cable to get the video signal back to the monitor or recording device.
- 3- They require a cable to transmit the "RS485 control signal" from the keypad or DVR to tell the PTZ to pan and tilt etc.
- 4- They require something to control them, either a keypad or a DVR.

The following diagram indicates the basic cable requirements for a PTZ system.

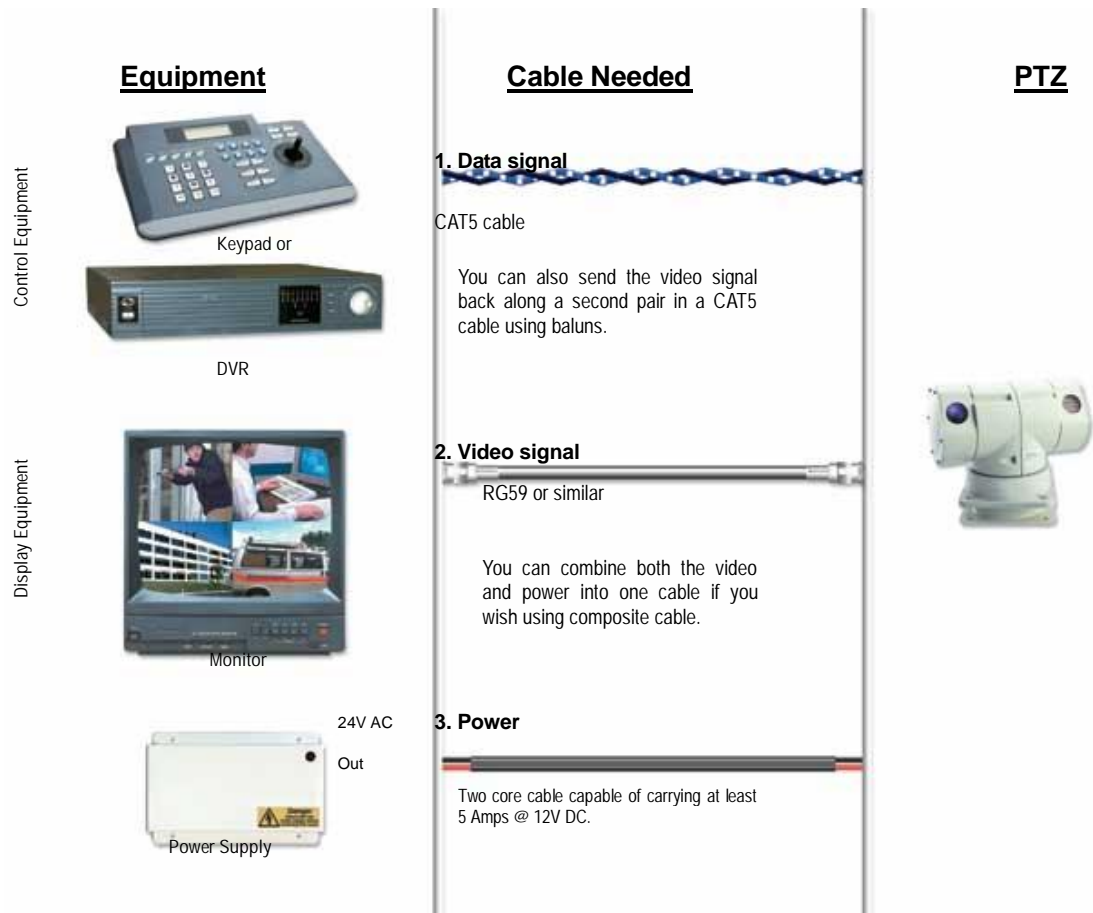

You can get “composite” cables that will carry both the power and the video signals and this has the benefit of combining two of the three cables into one. You may choose to power the PTZ locally to it, so you may only need to get the video signal back from the PTZ and the RS485 control signals to it. If this is the case you may choose to use a pair of BALUNS. By using baluns you can send the video signal and control signal down the same CAT5 cable just using different cores for each signal.

The control signal (RS485) is nearly always sent along a “twisted-pair” type cable. The twists in the cable help prevent interference affecting the data signal by “shielding” it. Many installation companies use a CAT5 type or similar cable to run out to the PTZs to carry the data signal.

If you are considering using baluns please note - DVR’s tend to require very good video signals to function correctly and “passive baluns” can lose some signal strength over the 50 meter mark so try to restrict the use of passive baluns to below 50 meter cable runs when using them with DVRs. Above this distance perhaps consider an active balun. Active baluns require power, passive baluns do not.

You can mix and match how you wire up your PTZ installation and the following general diagram gives you a guideline about how to do it. Remember this is a GUIDE and is not an instruction what to fit!

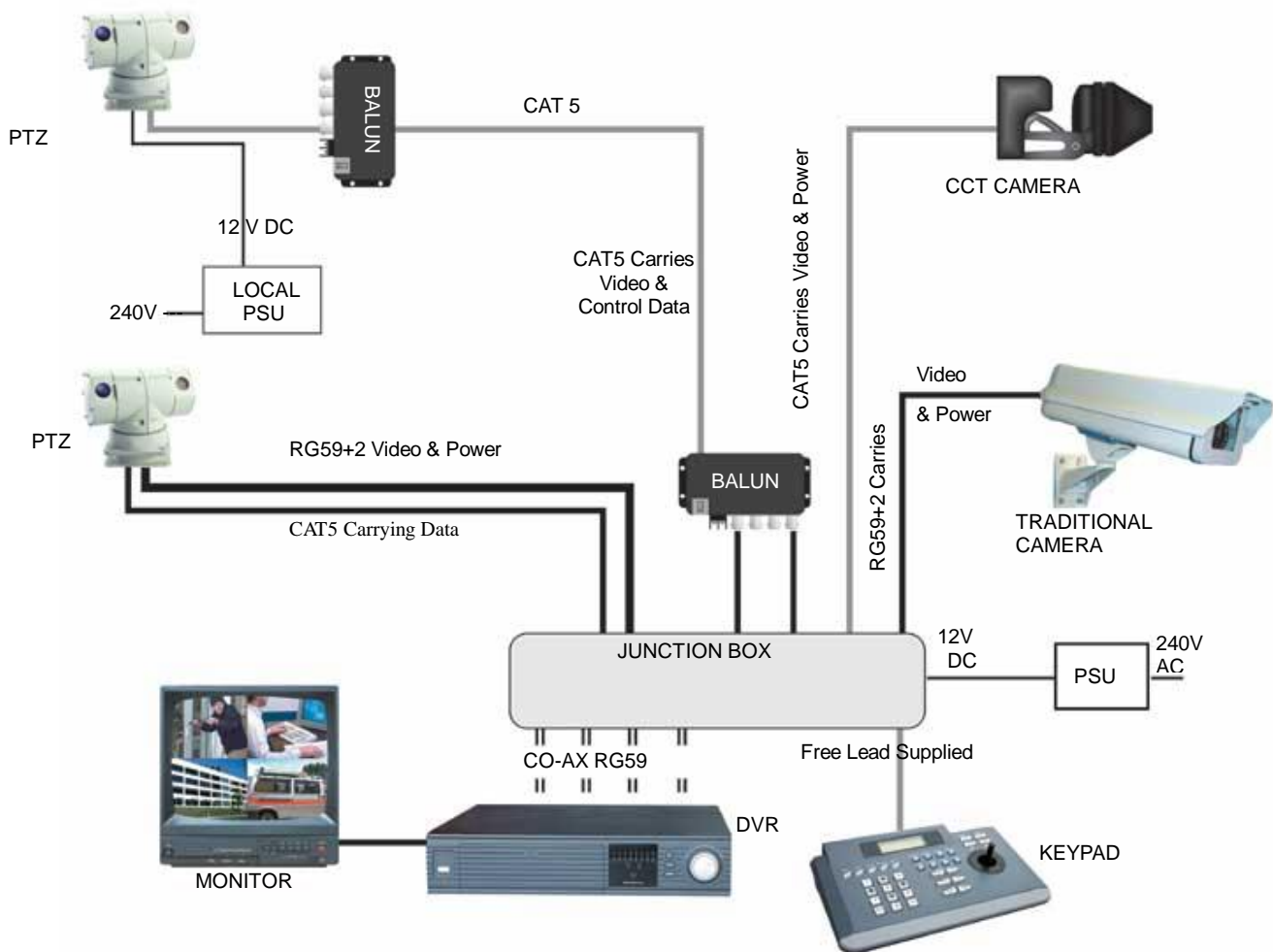

Many installation companies can get the power and video signal correct, but struggle with the control of the PTZ using the keypad or DVR using the RS485 data.

The key to successfully installing the data cabling to the PTZ is to get the basics right. Use a quality data cable such as CAT5 (never use just a standard untwisted cable such as alarm cable for the RS485 signal).

Also, you must follow the RS485 wiring convention; the following section explains this:

RS485 Wiring methods & Tips >>>>>

1. Characteristics of RS485

As specified by RS485 standards, RS485 is a half-duplex data transmission type with characteristic impedance of 120Ω . The maximum load capacity is 32 units (PTZs, keyboards and DVRs).

2. Transmission distances of RS485 Signals using CAT5 or similar cables

Selecting a CAT5 or similar sized twisted pair data transmission cable, the maximum theoretical transmitting distances are as follows:

Baud Rate	<u>Maximum</u> Transmitting Distance
2400 Bps (PELCO-D)	1500m
4800 bps	1000m
9600 bps	600m

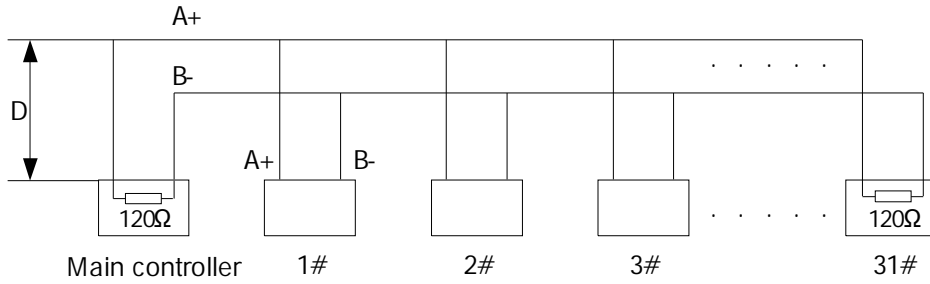

Daisy-Chain connection WITH SHORT SPURS for the RS485 PTZ control signal

(one main radial with very short spurs to each PTZ off it, keeping the spurs to less than 10 meters)

TIP - The connection of a 120 Ω termination resistor: The JP1 termination resistor is ready fitted on the PTZ pcb, all you have to do to set it, is to move the jumper from Pins 2 &3 to pins 1 & 2.

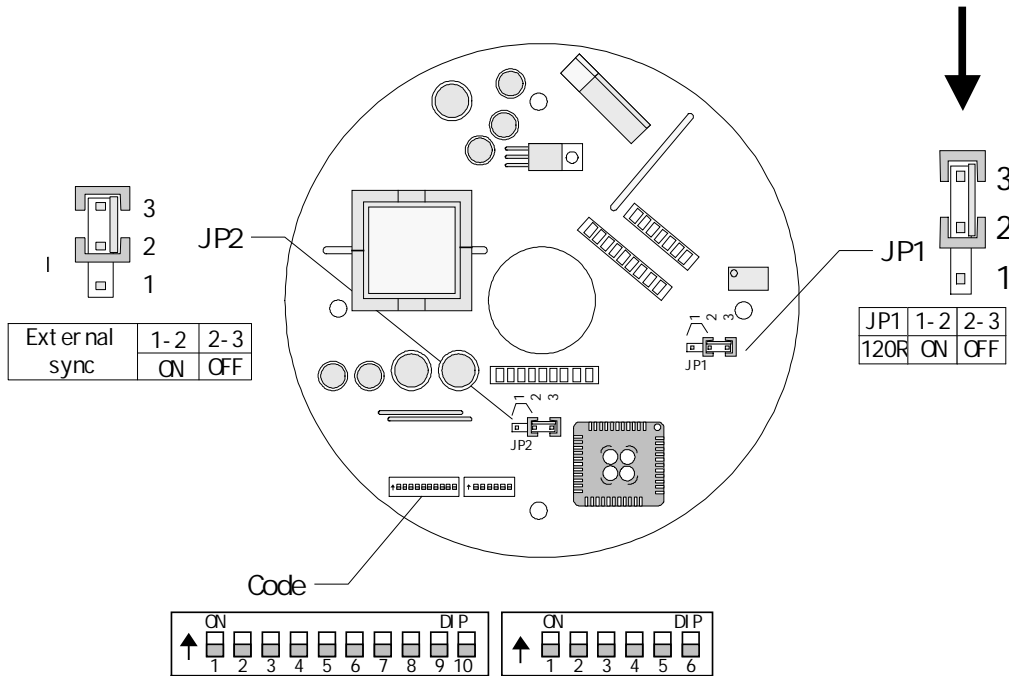

SPECIAL NOTE:

DO NOT GET THE TWO JUMPER SWITCHES CONFUSED.

JP1 IS THE 120 Ω TERMINATION & JP2 IS THE EXTERNAL SYNCHRONISATION

ON THIS PTZ905 12V DC PTZ, THE JP2 JUMPER MUST BE SET TO EXT SYNC OFF

The JP2 jumper is the connection terminal for the external synchronisation of the PTZ which provides a synchronised signal to the internal camera.

STAR method of connection.

In some circumstances you may need to adopt a star configuration for practical purposes. For instance, all the PTZs may be so scattered on a large site that running out separate spurs to each PTZ in a “STAR” array is the only practical solution.

So how do you do this in practice?

The termination resistors must be connected to the two PTZs that are furthest away from each other, such as PTZs 3 and 5 in the following “Star diagram”. Note that all the other PTZs do not have the 120 Ω resistor connected. The resistors are already fitted to the PTZ’s PCB but by default are not in circuit. To put them in circuit you must move the small “jumper” as previously indicated.

As the star configuration is not in conformity with the requirements of RS485 standards, problems such as signal reflections may arise, especially when there are long cable connections. The results are that control signals are decreased and the PTZ may not respond to, or just responds intermittently to the controller.

If your STAR circuit is not too extensive with each spur in the region of 20-50 meters you can expect quite good reliable performance using this technique. If you experience any problems though, there is a RS485 distribution box available CODE PT750 to help overcome any problems.

The Star circuit for wiring PTZ’s.

The two furthest PTZs need the 120 Ω resistors enabling, by moving the “Jumper”
In this example it’s PTZs 3 & 5.

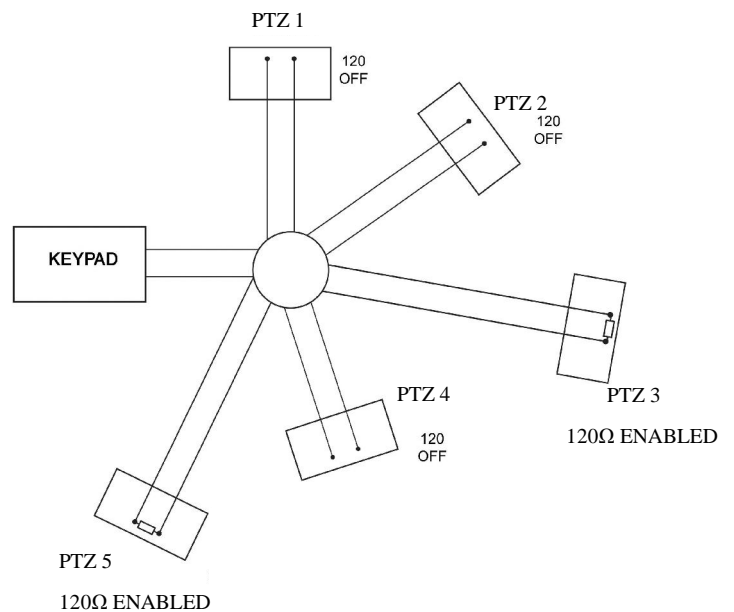

Overcoming RS485 data loss using an RS485 distributor

In the real world not everything always works exactly as it’s expected to!

RS485 data signals that control the PTZs’ movements are tiny signals that can get corrupted for many reasons. Poor cable quality, not using a PAIR of cores from a CAT5 but using one core from TWO separate pairs, running the CAT5 cable near mains equipment such as florescent lighting all will have a detrimental effect on the signal. These are things that you can correct with good installation practices.

Where you wish to run several separate CAT5 cables out to send the RS485 data signal out to the PTZs you

are in effect correcting the STAR method of RS485 data distribution. As previously mentioned the problem with the Star method is that it is not actually designed for RS485 but generally works okay if you follow the previous notes on getting the $120\ \Omega$ resistor setting right, as per the previous notes. One way that takes the guesswork out of installing the Star method is to utilise an RS485 distributor. This has the advantage that the RS485 signal is correctly distributed to the PTZs so that they behave as expected. You can create up to 4 spurs to the PTZs and put up to 4 PTZs on each spur. Just like the Daisy chain method the end PTZ on each spur needs to have the $120\ \Omega$ resistor enabled.

Although the RS485 distributor is a small additional expense, it takes some of the guess work out of the installation design and gives a more flexible approach to cabling which itself can save time and money on the installation. Not forgetting you get more predictable results!

The RS485 distributor (PTZ750) amplifies the RS485 control signal and distributes it evenly to 4 separate spurs, each spur can have up to 4 PTZs. This means that you could theoretically have up to 4 individual spurs of over 1000 meters each to control up to 16 PTZs in total.

Ideally you would put just one PTZ on each spur from the PTZ750 but up to 4 PTZs are generally acceptable. The following diagram shows a typical use of the PTZ750 RS485 distributor.

In the following example and diagram, PTZs 1,4,5 and 7 are at the end of each spur and therefore require the $120\ \Omega$ resistor enabling by moving the jumper setting within the PTZs. PTZs 2,3 and 6 are all “midway” in each spur and do not need the $120\ \Omega$ resistor and can be left as default. The PTZ750 itself has four $120\ \Omega$ resistors built in as shown and you do not have to do anything with the PTZ750 as the resistors are permanently connected within it.

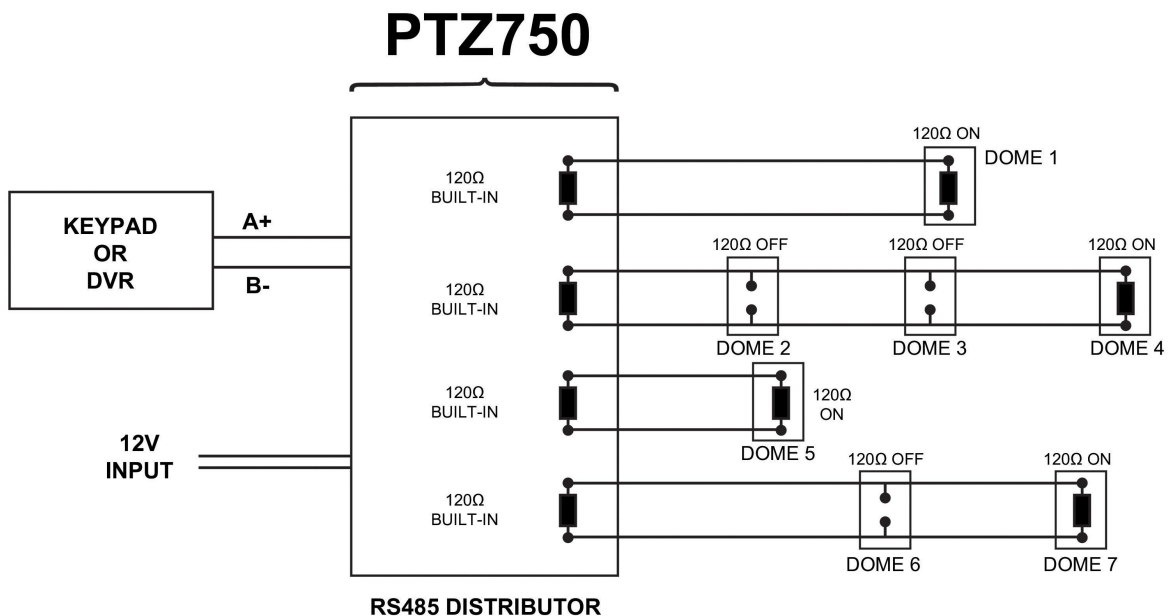

(Diagram showing how to use an RS485 distributor to improve PTZ control reliability)

Please note if you have the PTZ750 located within 5mtrs of the keypad or DVR you can connect up

to 3 of them in parallel.

Setting up the PTZ Camera

1. Connection of the System

There are many ways to wire up a PTZ system.

If you have read the introduction at the beginning of these instructions you should have got a good idea what your options are.

Below is a general schematic diagram showing you some of these options.

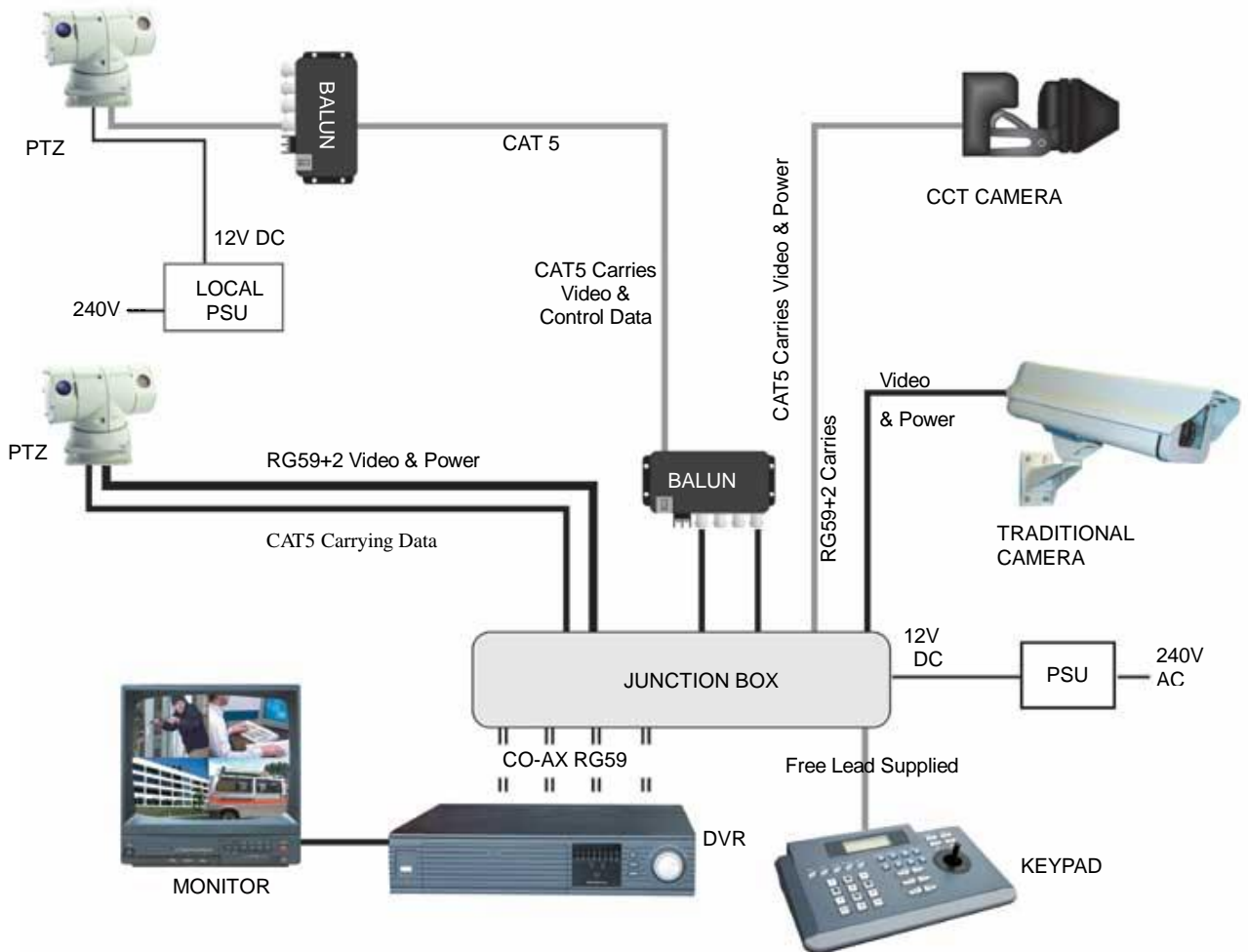

Powering the PTZs-

All the PTZs will need power. For this PTZ it is a 12V DC power supply. The power supply must be capable of delivering at least 2.8Amps per PTZ.

You can either power each PTZ with its own PSU locally to it or have the PSU's remotely situated perhaps near the keyboard or DVR. The PTZs require a current of about 2Amps so you must take this into consideration when working out maximum cable runs.

A popular way to power the PTZs is using our COMPOSITE VIDEO cable (or shotgun as its also known) as this cable can carry the power to the PTZ and the video signal back to the monitor or DVR.

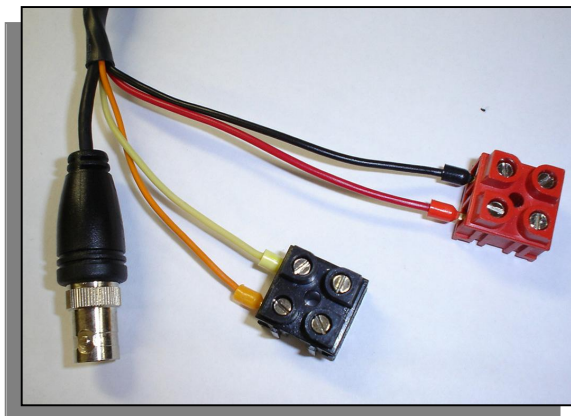

The power connection

The RED & BLACK cable coming out of the PTZ connected to the RED terminal block are for power. Connect a suitable 12V D.C power supply to this pair of cores.

The BNC connector is the “VIDEO-OUT” from the camera and goes to the monitor or “VIDEO-IN” of a DVR camera input.

The Orange and Yellow pair of cores that go in to the BLACK terminal block are the data cables. These are the cores that carry the RS485 control signal to the PTZ from either the keyboard or the DVR. The next section of the instructions gives more detail on how to connect the RS485 data. Please also read the RS485 WIRING METHODS & TIPS section towards the beginning of these instructions.

If the voltage of the PTZ drops below around 10V D.C it will fail to initialise. Obviously you can power the PTZs locally if you wish.

RS485 connection - *Connecting the Keypad or DVR to the PTZ905.*



The PTZ905 is controlled by an RS485 data signal that is given by either a KEYPAD or a suitable DVR. This data signal tells the PTZ to pan, tilt, zoom etc. Its important that you read the early section of these instructions to understand the fundamental principle of RS485 cabling techniques so that you get it right.

RS485 has two cores, A and B or sometimes known as RS485 + (A) and RS485 – (B) if you get these two the wrong way around then you will not be able to control the PTZ905. Sometimes installers get the connections right on one PTZ but not on the other and find only one PTZ works. They then swap the wires around at the keyboard only to find out one PTZ has now burst into life and the other one now failed!! But they don't put 2 + 2 together and realise their mistake that they have wired one PTZ different to the other. Take great care getting these the right way around and make sure you wire each PTZ IDENTICALLY so that

if you have to swap the A & B lines over at the keyboard you know all PTZs are wired the same!!

The PTZ905 series adopts the following RS485 convention:

ORANGE = RS485 + or A
YELLOW = RS485 – or B

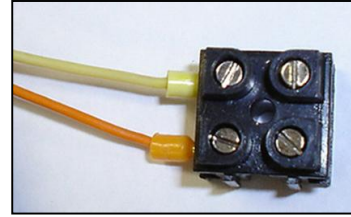

You should initially be wiring the PTZ905 to the keyboard or DVR on your workshop bench or at least your kitchen table to prove you know how to get everything to work. Once you have done this, it is just a job of extending the cables and physically installing the PTZs on site. You must obviously take note of the RS485 wiring techniques mentioned at the beginning of these instructions and get the 120 Ω resistors correct in the “End of line” PTZs. Generally speaking you will always be extending the RS485 signal from either the keypad or the PTZ using a CAT5 or similar cable.

The Keyboard models type CCT786 & CCT768 are supplied with a connecting lead and a break out box that looks like the following picture.



The RJ45 lead supplied with the keyboard connects into the rear of the keyboard into the slot marked “OUT” do not connect it to the “IN” position by mistake.



This lead provides the RS485 A and RS485 B connections from the keyboard. It is this cable that you would extend using one pair of conductors from a CAT5 cable. To test the PTZ on your workbench you can obviously omit the “extension” cable as the PTZ and keyboard are next to each other.

Now connect the RS485 data cable to the breakout box. Note that the orange connection is the RS485 + A Line connection and the yellow is the RS485 – B Line connection. The following picture shows the breakout box with the actual PTZ connected straight to it. The orange of the PTZ connects with the orange of the breakout box and the yellow of the PTZ connects with the white of the breakout box.

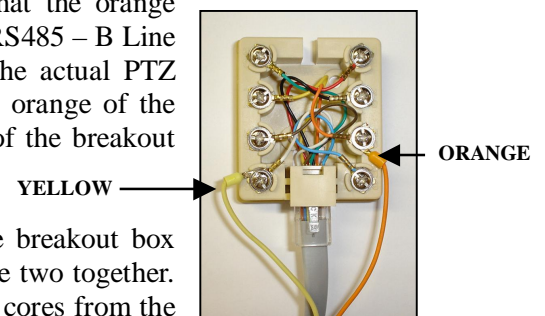

Obviously if the PTZ was on site you could not connect it to the breakout box directly. This is where you would use the CAT5 cable to connect the two together. You could use any pair out of the CAT5 cable but they must be two cores from the same pair. Why not use for example the orange pair so that the colours tie together a little? If you use cores from two different pairs in the CAT5 cable you will not get the benefit of the shielding effect of the cable twists and the PTZ905 will function erratically. You must always use a core from a PAIR, not two cores from two different pairs!!

Connecting the video out of the PTZ.

The PTZ905 has a short BNC lead attached to it, this is the lead that carries the video signal from the built-in camera. You need to extend this lead to the “VIDEO-IN” of the DVR or monitor. Use a good quality RG59 coax cable or similar to do this.

TIP – If you can’t get a picture at the remote end you could always take your test monitor to your PTZ and check the picture quality on its own short BNC lead.

If you’re testing the equipment on a workbench you now have a one PTZ system.

For setting up the keyboard and testing the PTZ please read sections on default PTZ settings and using the keyboard.

You can use a keyboard or a suitable DVR to control the PTZ905. A suitable DVR would be one with PTZ functionality built into it and preferably Pelco-D protocol. If your DVR has a list of protocols it’s always best to try “JEC” first or “Pelco-D” protocol, as these are very widely available. In the DVR, with either JEC or Pelco-D set, you must also make sure you set up the “baud-rate” to 2400. JEC protocol is very similar to Pelco-D but has a wider tolerance.

A typical site installation would look like the following diagram on the next page.

It shows the PTZ connected to the keypad plus how the PTZ could also be connected to a DVR instead of the keypad or at the same time. DVR’s that have the capabilities of PTZ control will have a terminal or connection on them somewhere, where the PTZ’s RS485- A and RS485- B line can connect to. Please refer to the individual DVR instructions of how to do this.

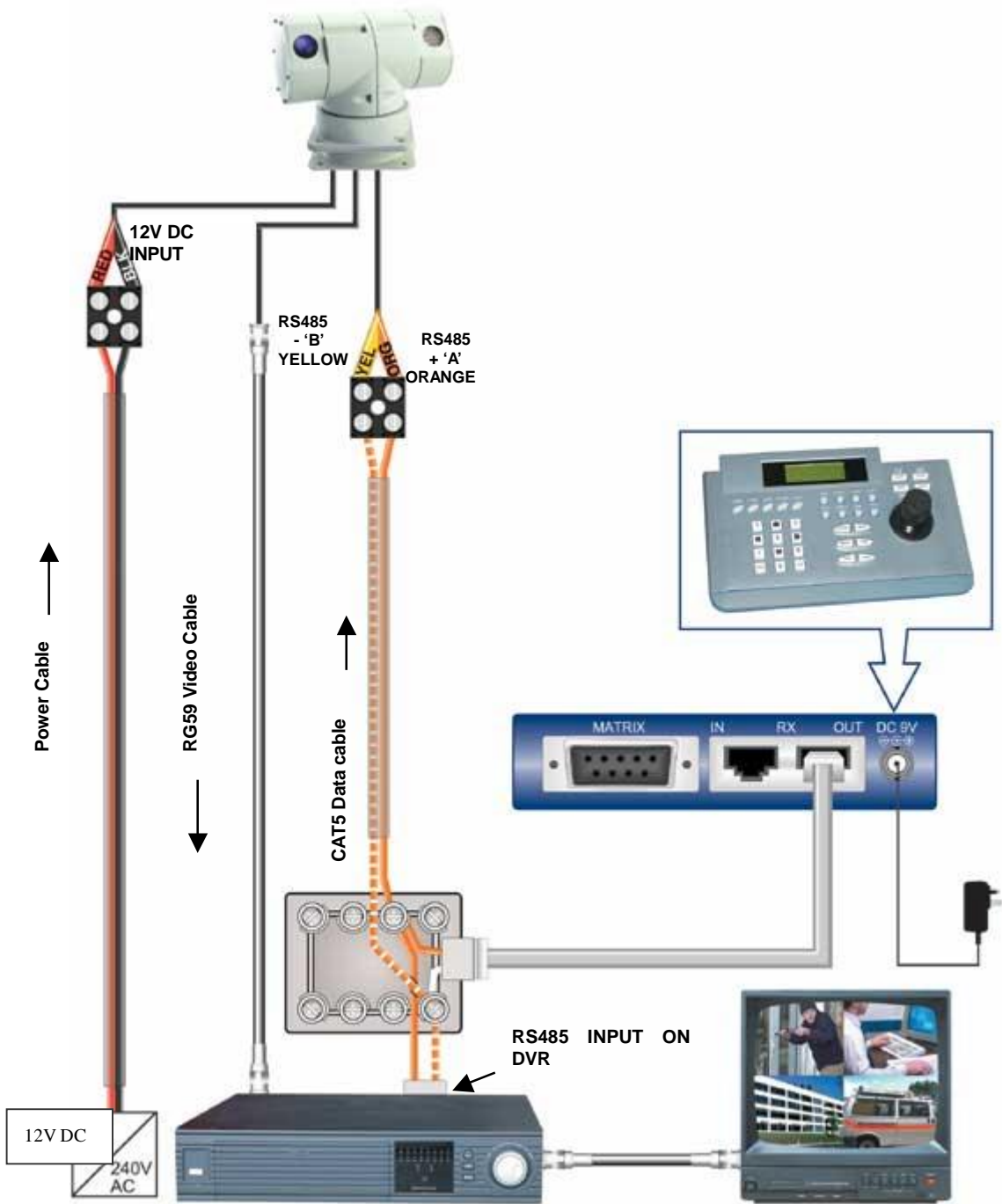

If you're using more than one PTZ on a site

Each PTZ has a unique “address” so that if you are using more than one on a site the keyboard “talks” to the right unit when you want it to PTZ. If you only have the one PTZ on the site then the default “address” of “1” is okay and you have no reason to change the PTZ from this.

With multiple PTZ sites you need to set up each PTZ address separately.

The following diagram shows the switch options.

SW2 sets up the protocol. This switch is dealt with later in these instructions.

For most System Q equipment they should always be set to PELCO-D 2400 baud rate. In the diagram this is correct. The Jumper on the far right either enables or disables the 120 Ω resistor.

Setting up a unique ADDRESS in the PTZ900 –

SW1 is used to set address of the PTZ900 from 1 ~ 1023.

To set the PTZ address at 1 put switch 1 up.
 To set the PTZ at address 2 put switch 2 up.
 To set the PTZ at address 3 put switches 1 & 2 up.
 ..and so on..

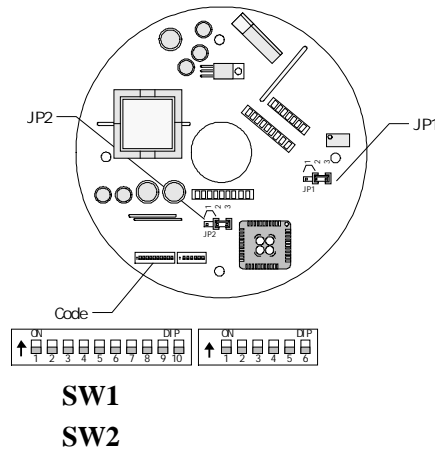

The following table indicates how this is done.

<p>Speed Done Address=1</p>	<p>Speed Done Address=2</p>	<p>Speed Done Address=3</p>
<p>Speed Done Address=4</p>	<p>Speed Done Address=18</p>	<p>Speed Done Address=1023</p>

Dome Address	ID-CODE Status									
	DIP-1	DIP-2	DIP-3	DIP-4	DIP-5	DIP-6	DIP-7	DIP-8	DIP-9	DIP-10
1	ON	OFF	OFF	OFF	OFF	OFF	OFF	OFF	OFF	OFF
2	OFF	ON	OFF	OFF	OFF	OFF	OFF	OFF	OFF	OFF
3	ON	ON	OFF	OFF	OFF	OFF	OFF	OFF	OFF	OFF
4	OFF	OFF	ON	OFF	OFF	OFF	OFF	OFF	OFF	OFF
5	ON	OFF	ON	OFF	OFF	OFF	OFF	OFF	OFF	OFF
6	OFF	ON	ON	OFF	OFF	OFF	OFF	OFF	OFF	OFF
7	ON	ON	ON	OFF	OFF	OFF	OFF	OFF	OFF	OFF
8	OFF	OFF	OFF	ON	OFF	OFF	OFF	OFF	OFF	OFF
9	ON	OFF	OFF	ON	OFF	OFF	OFF	OFF	OFF	OFF
10	OFF	ON	OFF	ON	OFF	OFF	OFF	OFF	OFF	OFF
11	ON	ON	OFF	ON	OFF	OFF	OFF	OFF	OFF	OFF
12	OFF	OFF	ON	ON	OFF	OFF	OFF	OFF	OFF	OFF
13	ON	OFF	ON	ON	OFF	OFF	OFF	OFF	OFF	OFF
14	OFF	ON	ON	ON	OFF	OFF	OFF	OFF	OFF	OFF
15	ON	ON	ON	ON	OFF	OFF	OFF	OFF	OFF	OFF
16	OFF	OFF	OFF	OFF	ON	OFF	OFF	OFF	OFF	OFF
17	ON	OFF	OFF	OFF	ON	OFF	OFF	OFF	OFF	OFF
18	OFF	ON	OFF	OFF	ON	OFF	OFF	OFF	OFF	OFF
...
1023	ON	ON	ON	ON	ON	ON	ON	ON	ON	ON

Table 1

2. Setup of the Protocol and the Default Baud Rate.

As shown in Table 2, SW2 is used to set the protocol and the baud rate used by the PTZ camera. DIP-4 to DIP-1 of SW2 is used to select protocols and a maximum of 16 different protocols can be selected. Pelco-D 2400 is used for most System Q equipment.



Protocols	DIP status				Normal Baud Rate	
	DIP-1	DIP-2	DIP-3	DIP-4	DIP-5	DIP-6
SAMSUNG	ON	OFF	OFF	OFF	OFF	ON
B01	ON	OFF	OFF	OFF	OFF	ON
NEON	ON	OFF	OFF	OFF	OFF	ON
Santachi	OFF	ON	OFF	OFF	OFF	ON
PELCO-D	ON	ON	OFF	OFF	OFF	OFF
PELCO-P/4800	OFF	OFF	ON	OFF	ON	OFF
PELCO-P/9600					OFF	ON
PANASONIC	ON	OFF	ON	OFF	OFF	ON
Longcomity	OFF	ON	ON	OFF	OFF	ON
HUNDA600	ON	ON	ON	OFF	OFF	ON
LILIN	OFF	OFF	OFF	ON	OFF	ON
VICON	ON	OFF	OFF	ON	ON	OFF
MOLYNX	OFF	ON	OFF	ON	OFF	ON
KALATEL	ON	ON	OFF	ON	ON	OFF
VCL	OFF	OFF	ON	ON	OFF	ON
Reserved	ON	OFF	ON	ON	OFF	ON
ALEC	OFF	ON	ON	ON	OFF	ON
Ultrak	ON	ON	ON	ON	OFF	ON

Some protocols and the setting of the dipswitches on normal baud rates for these protocols are shown as follows:

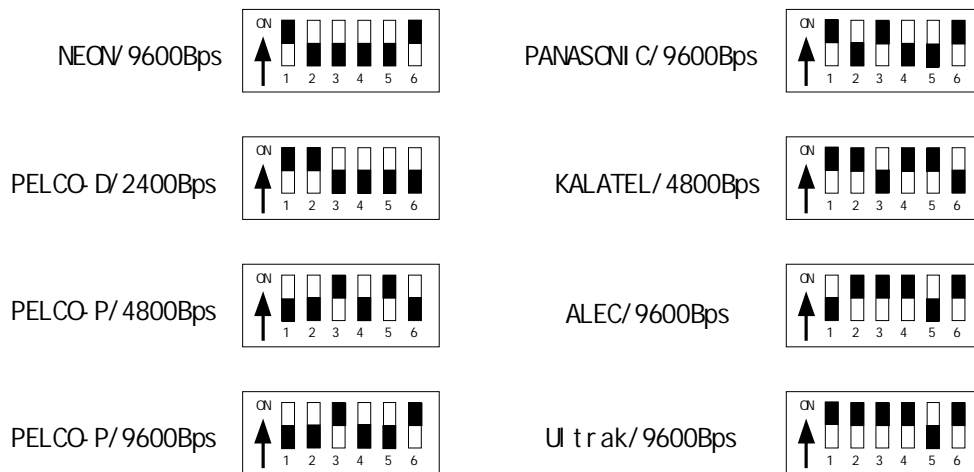

Setup of the Baud Rate.

As shown in Figure 2, SW2 is used to set the protocol of communication and the baud rate used by the PTZ905 camera. DIP-6 and DIP-5 of SW2 are used to select the baud rate and 4 different baud rates can be selected. If the controller adopts a non-standard baud rate, you can adjust it to be identical with that of the controller, as per the following table.

Baud Rate of Communication	DIP-1	DIP-2	DIP-3	DIP-4	Setup of Baud Rate	
					DIP-5	DIP-6
2400bps					OFF	OFF
4800bps					ON	OFF
9600bps					OFF	ON
19200bps					ON	ON

Using the CCT786 and CCT768 keyboard with the PTZ905



NOTE: For MINI 2D Keyboard type PTZ700 please refer to the instructions supplied with the actual PTZ700 keyboard.

The CCT768 & CCT786 keyboards require a 12V PSU (350ma) that is usually the plug in type. When you first take the keyboard out of the box you will need to set it up for the PTZs that you are using.

The PTZ you have purchased has the default settings of; PELCO-D 2400-BAUD rate Address 1

If you look at the image of the LCD display below you can see the CAM=001 indicates that the keyboard is ready to talk to camera with address 1, if you have another PTZ set at camera address 2, press 2 followed by CAM. This would change the screen to CAM=002.

If you have multiple PTZs you will need to change the address of each PTZ so they are different but PLEASE LEAVE THE PTZs ON PELCO-D 2400 BAUD RATE.

There is an LCD display on the keypad.
When power is connected this will display something like the following: >>>

The current protocol (protocol D or P)
The current camera address (each P/T device requires a unique address 1-32)
The current baud rate



LCD of keypad CCT786 & CCT768 with correct default setting for this PTZ at address 1

To set up the keyboard to the correct settings for this PTZ do the following:

KEY SETTINGS FOR THE PTZ – ENTER THESE into the keyboard type CCT768 & CCT786

For **2400-BAUD** rate: Input 24 and press the PRG key (default PTZ setting)

To select **PROTOCOL D**: enter 44 and press the PGM key (default PTZ setting)

To select **CAMERA ADDRESS 1** press 1 and then press the CAM key (default PTZ setting)

TIP - For advanced uses the keyboard also can also adopt the following features (these settings are not used for this PTZ!!!)

These parameters can all be changed in the following manner:

To select PROTOCOL P: enter 50 and press the PGM key

For 1200-BAUD rate: Input 12 and press the PRG key

For 4800-BAUD rate: Input 48 and press the PRG key

For 9600-BAUD rate: Input 96 and press the PRG key

PRESETS and other functions.

The PTZ905 has up to 128 presets that once programmed will stay in the PTZ's non-volatile memory so they will be retained even after a power cut.

What is a preset? A preset is a particular area or object that the PTZ was looking at and has been stored into its memory so when the preset is "called-up" the PTZ will select the area again without the operator using the joystick to do this. Even the zoom at the time is stored into the preset. This means that you could for example store a PRESET of a car-park entrance. When the operator calls up this preset the camera automatically zooms in on this area. By storing more than one preset you can add even more functionality to the PTZ. By having two presets, you can then get the PTZ to "SCAN" between the two locations. You can even vary the speed of this scan.

Having 3 or more presets you can get the PTZ to go on a TOUR (PATROL) of the presets. When you run the patrol the PTZ goes to one preset, then waits a short period then on to the next preset and so on. The PTZ continues to cycle around this patrol until you cancel it. The length of time the camera stays at one location and the speed of travel between each preset point can be set in the menu.

PRESETS -How to set up a preset

Aim the PTZ where you want it to look, zoom in or out to get the correct scene and let the camera auto focus. Now press the following keys on the keypad : **xx PRESET** (where **xx** is the preset number you wish to store). For example **01 PRESET** would store **PRESET 01** and the camera would always go to this location when **01** is "CALLED".

To test if the preset is stored correctly use the joystick to move the camera to a point in a new location. Now press **xx CALL** (where **xx** is the preset you wish the camera to go to). In this example if you press **01 CALL** the PTZ905 should go straight to the PRESET 01 location.

TIP -You may wish to write down a list of presets that you have stored next to the keypad for the operator.

CALLING a preset

This may be as follows:

PRESET 01 = MAIN GATE (a long zoom shot)

PRESET 02 = ENTRANCE DOOR

PRESET 03 = FIRE ESCAPE

PRESET 04 = EMERGENCY EXIT

PRESET 05 = CAR PARK (zoomed-out wide angle)

PRESET 06 = CAR PARK (zoomed-in narrow angle)

When the operator wishes to quickly zoom in on the MAIN GATE all he has to do is press **01 CALL**.

To go to the EMERGENCY EXIT he would press **04 CALL** and so on.

To call up any previously stored preset camera location, simply press **xx CALL**, where **xx** is the preset number.

Patrols (Tours) – How to set them up and use them

A patrol (tour) is simply a collection of at least three preset camera locations that are run in sequence with the PTZ stopping at each location for a brief period of time and then moving on to the next preset.

For example, you could use a patrol so that an outside PTZ camera points at a gate, then at a side doorway, then zooms out to get an overall shot of a car park and finally zooming in on a delivery bay, before repeating the whole cycle again. Patrols can be useful for both outside and internal PTZ's. For a shop they could be used to cover key areas like clothes rails, tills and changing rooms in a sequence.

To set up a patrol you need to set up the individual stop points where the camera will pause. These are called *presets*.

An example four preset mini-tour

Setting the presets using the keypad

STEP 1- Using the keypad joystick, move to where you wish to start the tour and then press **01 PRESET**

STEP 2- Now move to the next location and press **02 PRESET**

STEP 3- Now move to the third location and press **03 PRESET**

STEP 4- Finally move to where you wish to end the tour and press **04 PRESET**

Deleting a preset

You may wish to delete a preset.

To do this press **xx PRESET** holding the preset button down for 3 seconds at the end.
(xx = preset number).

As you are holding the preset button down for the 3 seconds you will see the preset number go to 000 on the keypad. This means that the preset has been deleted.

For example to delete preset 1, press **01 PRESET** (holding the preset button for 3 seconds.)

Obviously if you wish to overwrite a preset with a new location, simply aim the camera at the new location and store the preset as normal, this will simply overwrite the old preset.

Setting the Patrol (Tour)

To setup the patrol/tour you need to enter the Advanced Menu System by selecting **95 CALL** on the keypad. You will see the **Main Menu** displayed on the screen.

Using the joystick up/down direction movement, select the **PROGRAM** menu. Use the joystick pan right movement to enter this menu.

Now use the Joystick up/down direction movement to select **SET PATROL**. To the right of this, is the patrol sequence number. By moving the Joystick to the right this number can be increased from 1 ~ 6 (up to six patrols/tours can be programmed) or decreased using the left direction movement. Start with sequence **01**.

Now press the **OPEN** button to select edit mode. A table will be displayed showing 16 patrol item numbers. Note that the screen is divided into two halves with two patrol positions per line. Only the odd patrol item numbers are identified down the left hand side of the display. In the bottom left hand corner the patrol sequence number is displayed. This can be 01 ~ 06.

In the example we are setting four presets in the first patrol sequence.

To edit a patrol sequence

NO Patrol Item No.
POS No. of Preset Position
SP PTZ speed (0, 1~8)
 0 and 1 are fastest speed –
 8 is slowest speed
TM Dwell time at this position
 Time 0 ~ 99 seconds

NO	POS	SP	TM	POS	SP	TM
01	001		01	01	002	01
01						
03	003	01	01	004	01	01
05	---	--	--	---	--	--
07	---	--	--	---	--	--
09	---	--	--	---	--	--
11	---	--	--	---	--	--
13	---	--	--	---	--	--
15	---	--	--	---	--	--
SEQ:01				CLOSE.EXIT		

SEQ:nn The Patrol number. (01 ~ 06)

Special Note: The patrol item number (**NO**) is an ascending number list of the preset items within this sequence. It may not necessarily reflect the actual preset number. You could for instance have preset item (NO) 01 with preset position 004 as the first preset required.

Enter the preset position number (**POS**), the PTZ speed (**SP**) and the dwell time (**TM**) for each preset by using the Joystick up/down movement. Move the Joystick to the right to move to the next field.

After including all the presets required in this patrol/tour, press the Keypad **CLOSE** button to exit. If you add extra presets later and wish to incorporate into a patrol/tour already created, you must add the additional preset positions in the necessary SET PATROL table sequence.

Now exit the menu by moving the Joystick down, selecting **EXIT** and then moving the Joystick to the right to return to the Main Menu. Again use the Joystick to select **EXIT** and exit the Advanced Menu System by selecting the right pan movement.

Calling the Patrol (Tour)

There are two methods of initiating the patrol or tour. If you enter **91 CALL** via the keypad you can initiate patrol/tour sequence 1 only.

You may also initiate a patrol or tour through the Advanced Menu System. Enter **95 CALL** on the keypad. You will see the **Main Menu** displayed on the screen.

Using the joystick up/down direction movement, select the **PROGRAM** menu.
Use the joystick pan right movement to enter this menu.

Now use the Joystick up/down direction movement to select **RUN PATROL**. To the right of this, is the patrol sequence number (**xx**). By moving the Joystick to the right this number can be increased from 1 ~ 6 (up to six patrols/tours can be programmed) or decreased using the left direction movement. Now press the **OPEN** button to initiate the patrol/tour sequence number.

Special Note: If you notice that some expected presets are not being incorporated in a patrol/tour, check that the SET PATROL table has been setup correctly and shows all presets for the required sequence. A full explanation of the values to be set can be found in the Advanced Menu settings under PROGRAM, SET PATROL and RUN PATROL.

TIP - To stop the PATROL just move the joystick slightly.

AUTO SCAN- How to set it up

Auto-scan scans between two points. These are not presets as per the patrol (tour) facility but auto scan selection points. You may program only one auto scan.

STEP 1 – Select the required camera by entering <camera address> and pressing the **CAM** button on the keypad.

Position the camera where you wish to start scanning from. To setup the Auto Scan you need to enter the Advanced Menu System by selecting **95 CALL** on the keypad. You will see the **Main Menu** displayed on the screen.

Using the joystick up/down direction movement, select the **PROGRAM** menu.
Use the joystick pan right movement to enter this menu.

In the PROGRAM menu select **AUTO PAN START POS** followed by pressing **CLOSE** button to save.

STEP 2 - Aim the camera where you wish to end the scanning point. Now select the PROGRAM menu **AUTO PAN END POS**, followed by **CLOSE** button to save.

Calling the Auto Scan

First you must set the start and end positions of the auto scan as above. This runs the auto scan function between these two points. There are two methods of initiating the auto scan. If you enter **97 CALL** via the keypad you can initiate the auto scan. Note that the 97 CALL will run at the speed set in the RUN AUTO PAN table.

You may also initiate the auto scan through the Advanced Menu System. Enter the Main Menu by selecting **95 CALL** on the keypad. You will see the **Main Menu** displayed on the screen.

Using the joystick up/down direction movement, select the **PROGRAM** menu.
Use the joystick pan right movement to enter this menu.

In the PROGRAM menu select **RUN AUTO PAN <speed>**. The speed is selected using the Joystick pan left or pan right. The following speed selection can be made: **FAST / NORMAL / SLOW / -FAST / -NORMAL / -SLOW**. There are 6 speed selections. The first three relate to scans up to 180° and the second three relate to scans greater than 180°. If the start position is the same as the end position it will do a 360° scan. Now press the **CLOSE** button to save and initiate the Auto Scan.

TIP - To stop the scan just move the joystick slightly.

RECORD PATTERN- What is a record pattern

This PTZ has an option to store a record pattern. A record pattern consists of a continuous sequence of standard pan and tilt movements or lens commands recorded within a 40 second interval. A record pattern does not use presets. You can limit movement at a required position and pan and tilt within the 40 second time restriction. Once the recording is complete, i.e you have closed the recording or the record time has expired, you may use an option in the Advanced Menu System to replay the recorded pattern. Once this recorded pattern is initiated, the PTZ will run the record pattern continuously until a keypad movement is detected or an alarm is activated.

RECORD PATTERN- What is the difference between a pattern & a patrol (tour)

A patrol (tour) uses presets and when initiated, the PTZ will move to a maximum of 16 preset positions using the speed attribute and the dwell times as set in the Program Patrol Table. The speed of PTZ movement between any two presets can be selected but this is a constant speed and not a variable speed. A patrol (tour) can run for an extensive length of time with a dwell time of a maximum of 99 seconds at each of sixteen preset positions. In addition up to six different patrols (tours) can be stored each with different preset parameters whereas only one record pattern can be recorded. When a preset is stored the PTZ905 stores not only the preset position but also the camera attributes.

A record pattern does not use presets. It however allows the user to record a continuous sequence of standard pan and tilt movements or lens commands but does not allow presets, flip, digital zoom, proportional pan or turbo speed. The record pattern sequence can be recorded using the keypad pan and tilt joystick but will only record up to a 40 second interval. A record pattern allows the user a continuous view rather than selected preset positions and is similar to an auto scan except that an auto scan only allows a selected movement speed whereas the record pattern reflects the user movements made during the recording of the record pattern.

RECORD PATTERN- How to set it up

Record Pattern allows a pattern to be recorded which consists of any standard pan and tilt or lens command within a 40 second interval. A pattern is automatically closed when the 40 second interval is exceeded or by pressing the CLOSE button. Note that the following are not allowed in a pattern: presets, flip, digital zoom, proportional pan and turbo.

STEP 1 – Select the required camera by entering <camera address> and pressing the **CAM** button on the keypad.

Position the camera where you wish to start the record pattern sequence. Enter the Advanced Menu System by selecting **95 CALL** on the keypad. You will see the **Main Menu** displayed on the screen.

Using the joystick up/down direction movement, select the **PROGRAM** menu.
Use the joystick pan right movement to enter this menu.

In the **PROGRAM** menu select **RECORD PATTERN** followed by pressing **CLOSE** button to save.

STEP 2 – Now move the camera using the keypad joystick to record a forty second sequence and follow this by pressing the **CLOSE** button to save. The record pattern will be stored for future replay.

Running the Record Pattern

First you must have recorded a record pattern as detailed above. This runs a record pattern of up to 40 seconds duration. You can run the Record Pattern through the Advanced Menu System. Enter the Main Menu by selecting **95 CALL** on the keypad. You will see the **Main Menu** displayed on the screen.

Using the joystick up/down direction movement, select the **PROGRAM** menu.
Use the joystick pan right movement to enter this menu.

In the **PROGRAM** menu select **RUN PATTERN**. Now press the **CLOSE** button to save and initiate the Record Pattern sequence. This will run continuously.

TIP - To stop the record pattern just move the joystick slightly.

USING THE PTZ905'S ADVANCED FUNCTIONS-

On Screen Graphics (OSD) –

The PTZ905 boasts six patrol (tour) options, an auto scan option and a record pattern option. All these can be configured using the OSD.

To bring up the camera menu press **95 CALL**. The OSD is then displayed on the screen. You can navigate between the various options using the Joystick control – up to increase and down to decrease – right pan to enter and left pan to exit. You can also use the OPEN button to enter and the CLOSE button to save and exit.

THE ADVANCED MENU SYSTEM

Using the Advanced Menu System.

This menu system allows the user to alter the PTZ menu instruction options and settings using a control keypad. This first page shows the initial main menu page and only describes the general functions. The following pages show the main menu option selected on the left hand side of the page and a breakdown of that menu page on the right hand side of the page.

MAIN MENU

To enter the main menu system press **95 CALL** on the Keypad.

Use the Joystick control pan up or pan down to increase or decrease a value and pan left or pan right to enter a selection.

The OPEN button can also be used to enter a selection and the CLOSE button to exit.

To leave the main menu press EXIT in Main Menu.

DESCRIPTION OF MENU OPTIONS

DISPLAY SETUP: To set PTZ camera address display – set position of address – set preset title – set preset title position – open camera screen.

CAMERA SETUP: To set slow shutter – set backlight compensation – set low light shooting – auto/manual iris – digital zoom – auto/manual focus – white balance.

CONTROL SETUP: To set auto flip – alarm – preset freeze – set home function

PROGRAM: Set auto pan start & end – run auto pan – edit preset title – setup patrols/tours – run patrols /tours – record pattern – run pattern.

PAL CAMERA: To switch between PAL and NTSC camera mode.

CAM DEFAULT SET: To select camera default settings.

RESET PT: To reset the PTZ905.

EXIT: To exit menu.

MAIN MENU

1. DISPLAY SETUP
2. CAMERA SETUP
3. CONTROL SETUP
4. PROGRAM
5. PAL CAMERA
6. CAM DEFAULT SET
7. RESET PT
8. EXIT

DISPLAY SETUP

To access Display Setup press the **OPEN** button on keypad or move the Joystick to the right. The menu below will be displayed.

MAIN MENU

1. **DISPLAY SETUP**
2. CAMERA SETUP
3. CONTROL SETUP
4. PROGRAM
5. PAL CAMERA
6. CAM DEFAULT SET
7. RESET PT
8. EXIT



DISPLAY SETUP

ID DISPLAY	ON
ID POS	TOP-L
TITLE DIS	ON
TITLE POS	01 LINE
CAM DISPLAY	ON
RETURN	

DISPLAY SETUP MENU OPTIONS

ID DISPLAY ON / OFF

When set to ON the camera address of the PTZ appears on the screen e.g. CAM 001.

The default setting is ON. To toggle these settings move the Joystick to the right or press the OPEN button. To return to Main Menu use the Joystick down movement to RETURN and press the OPEN button on the keypad or move the Joystick to the right.

ID POS TOP-L / TOP-R / BOTT-R / BOTT-L

This allows user to position the camera address display at one of the following corners of the display: TOP-L (Top Left), TOP-R (Top Right), BOTT-R (Bottom Right) and BOTT-L (Bottom Left). To toggle these settings move the Joystick to the right or press the OPEN button. To return to Main Menu use the Joystick down movement to RETURN and press the OPEN button on the keypad or move the Joystick to the right.

TITLE DIS ON / OFF

When this is set to ON, the title of the preset point appears in the left of display when the preset is called. E.g. NO.001 ENTRANCE. The **PROGRAM** option is used to setup the title.

To toggle the settings move the Joystick to the right or press the OPEN button. To return to Main Menu use the Joystick down movement to RETURN and press the OPEN button on the keypad or move the Joystick to the right.

TITLE POS 01~10 LINE

This is used to set the display position of the preset title. Specify line number from 01 ~10.

Line 1 is at the top of the display and line 10 at the bottom. To toggle the settings move the Joystick to the right or press the OPEN button. To return to Main Menu use the Joystick down movement to RETURN and press the OPEN button on the keypad or move the Joystick to the right.

CAM DISPLAY ON / OFF

When this is set to ON the camera screen will be opened. To toggle the settings move the Joystick to the right or press the OPEN button. To return to Main Menu use the Joystick down movement to RETURN and press the OPEN button on the keypad or move the Joystick to the right.

RETURN

To return to Main Menu move the Joystick to the left or press the OPEN button.

CAMERA SETUP

Move the Joystick down to select Camera Setup and press the OPEN button or move the Joystick to the right. The menu below will be displayed.



MAIN MENU

1. DISPLAY SETUP
- 2. CAMERA SETUP**
3. CONTROL SETUP
4. PROGRAM
5. PAL CAMERA
6. CAM DEFAULT SET
7. RESET PT
8. EXIT

CAMERA SETUP

SLOWSHUTTER	AUTO
BACK LIGHT	OFF
ICR SHOT	AUTO
IRIS	AUTO
D-ZOOM	ON
FOCUS	AUTO
WB SET	ATW
MENU OF CAM	
RETURN	

NOTE: The following camera setup options depend on the camera type installed.

SLOW SHUTTER **AUTO / MANU**

Sets a manual shutter speed. In auto mode the electronic shutter is fixed on 1/50 sec after initialization. To toggle the settings move the Joystick to the right or press the OPEN button. To return to Main Menu use the Joystick down movement to RETURN and press the OPEN button on the keypad or move the Joystick to the right.

BACK LIGHT **ON / OFF**

Used to switch backlight compensation on or off. This can be used to improve image quality when the object viewed is dark or dim. This option allows the user to increase backlight compensation. To toggle the settings move the Joystick to the right or press the OPEN button. To return to Main Menu use the Joystick down movement to RETURN and press the OPEN button on the keypad or move the Joystick to the right.

ICR SHOT **ON / AUTO**

Low light shooting. This is used when the external brightness is extremely low. Normally the camera works in the automatic state but when the light level falls to below 1 Lux the camera can be switched to the zero luminance state. To toggle the settings move the Joystick to the right or press the OPEN button. To return to Main Menu use the Joystick down movement to RETURN and press the OPEN button on the keypad or move the Joystick to the right.

IRIS **AUTO / MANU**

Setup of automatic iris. To toggle the settings move the Joystick to the right or press the OPEN button. To return to Main Menu use the Joystick down movement to RETURN and press the OPEN button on the keypad or move the Joystick to the right.

CONTROL SETUP

Move the Joystick down to select Control Setup and press the OPEN button or move the Joystick to the right. The menu below will be displayed.



MAIN MENU

1. DISPLAY SETUP
2. CAMERA SETUP
- 3. CONTROL SETUP**
4. PROGRAM
5. PAL CAMERA
6. CAM DEFAULT SET
7. RESET PT
8. EXIT

CONTROL SETUP

AUTO FLIP	ON
ALARM	ON
PRESET PIC	MOVE
HOME OPTION	
IR LED	OFF
RETURN	

AUTO FLIP **ON / OFF**

This allows the setting of the 180° automatic flip of the dome camera. To toggle this setting move the Joystick to the right. To return to Main Menu use the Joystick down movement to RETURN and press the OPEN button on the keypad or move the Joystick to the right.

ALARM **ON / OFF**

This allows alarm activation to be set. To toggle this setting move the Joystick to the right. To return to Main Menu use the Joystick down movement to RETURN and press the OPEN button on the keypad or move the Joystick to the right.

PRESET PIC **FREEZE / MOVE**

Set this option to FREEZE if following a preset call, you wish to freeze the image. Otherwise set to MOVE to continue running. To toggle this setting move the Joystick to the right. To return to Main Menu use the Joystick down movement to RETURN and press the OPEN button on the keypad or move the Joystick to the right.

HOME OPTION **enter HOME OPTION sub menu**

To enter this option move the Joystick to the right. The submenu below will be displayed.



AUTO HOME **ON / OFF**

When this is set to ON the PTZ camera will return to home if there has been no action in a period of time. This does not apply if the PTZ camera is on a tour. If no home is needed when the camera is stopped, set the option to OFF.

HOME POS **01 ~ 63 or 65 ~ 128**

This setting allows the user to declare a preset position as the HOME position. You will

HOME OPTION	
AUTO HOME	ON / OFF
HOME POS	01
DWELL TIME	06 MIN
RETURN	

need to have previously created this preset position. To toggle this setting move the Joystick to the right. To return to Control Setup use the Joystick down movement to RETURN and press the OPEN button on the keypad or move the Joystick to the right.

DWELL TIME 1 ~ 99

This allows the user to set the time period in minutes before returning to HOME when there has been no action. To toggle this setting move the Joystick to the right. To return to Control Setup use the Joystick down movement to RETURN and press the OPEN button on the keypad or move the Joystick to the right.

RETURN return to CONTROL SETUP menu by moving Joystick to the left.

IR LED OFF/ON

The default option of the Infrared Lamp is OFF. Normally the PTZ905 detects external illumination and opens and closes the infrared lamp automatically. If the user changes this option to ON, the operation of the Infrared becomes a manual operation.

RETURN

To return to Main Menu move the Joystick to the left.

PROGRAM

Move the Joystick down to select **Program** and press the **OPEN** button or move the Joystick to the right. The menu below will be displayed.



MAIN MENU

1. DISPLAY SETUP
2. CAMERA SETUP
3. CONTROL SETUP
- 4. PROGRAM**
5. PAL CAMERA
6. CAM DEFAULT SET
7. RESET PT
8. EXIT

PROGRAM

AUTO PAN START POS
AUTO PAN END POS
RUN AUTO PAN SLOW
SET TITLE XX
SET PATROL XX
RUN PATROL XX
RECORD PATTERN
RUN PATTERN
RETURN

AUTO PAN START POS

To set the start position of an auto scan between two points, move the camera to the start position after selecting this option using the keyboard Joystick. Then press the **CLOSE** button.

AUTO PAN END POS

To set the end position of an auto scan between two points, move the camera to the end position after selecting this option using the keyboard Joystick. Then press the **CLOSE** button.

RUN AUTO PAN FAST / NORMAL / SLOW / -FAST / -NORMAL / -SLOW

This runs the auto scan function between two points. First you must set the start and end positions of the auto scan as above. If the start position is the same as the end position it will do a 360° scan. There are 6 speed selections. The first three relate to scans up to 180° and the second three relate to scans greater than 180°. The speed is selected using the Joystick pan left or pan right and to initiate the auto scan press the **OPEN** button.

SET TITLE

To edit titles of preset positions. Only 63 preset titles can be edited. Select preset point number using the Joystick pan left or pan right, press **OPEN** button to enter **EDIT MODE** and **CLOSE** to exit.

EDIT PRESET POINTS

To edit title of preset point. Move cursor using the Joystick pan left or pan right and modify the title using the Joystick UP/DOWN controls. Press **CLOSE** button to save modifications and exit. The title can be up to 8 characters long, consisting of

PRESET NO: 01
TITLE: NO TITLE

CLOSE:EXIT

0-9, A-Z, +, - and space.

NOTE: The first character of the title must be 0-9 or A-Z.

SET PATROL

To edit data for a patrol/tour. Select sequence number of patrol by using the Joystick pan left or pan right, press OPEN button to select edit mode and edit using the up/down Joystick movement, setting the POS (preset number), the Joystick pan right to select the PTZ speed (SP) and the dwell time (TM) followed by the CLOSE button to save and exit.

EDIT PATROL SEQUENCE

To edit a patrol sequence

NO Patrol Item No.
POS No. of preset position
SP PTZ speed (0, 1~8)
0 and 1 are fastest speed –
8 is slowest speed
TM Dwell time at this position
Time 0 ~ 99 seconds

NO	POS	SP	TM	POS	SP
01	001	01	01	002	01
03	003	01	01	004	01
05	---	--	--	---	--
07	---	--	--	---	--
09	---	--	--	---	--
11	---	--	--	---	--

SEQ:nn The Patrol number. (1 ~ 6)

Note that two patrol points are set on each line of this menu. The CLOSE button closes and stores the new settings. The program searches for the first --- and any data following is regarded as invalid data. In the example above the program stores four preset positions numbers 01~04. However the settable range can be from 1 to 63 and from 65 to 128. You can set up to 16 preset positions per Patrol sequence and you can have up to 6 patrol sequences.

RUN PATROL

To run a multi-point patrol select the Sequence Number of the Patrol using the Joystick pan left and pan right, and run using the OPEN button.

Special Note: If you notice that some expected presets are not being incorporated in a patrol/tour, check that the SET PATROL table has been set up correctly and shows all presets for the required sequence.

RECORD PATTERN

This option allows a pattern to be recorded which consists of any standard pan and tilt or lens command. **Presets, flip, digital zoom, proportional pan and turbo are not allowed in a pattern.** The pattern length lasts for 40 seconds maximum and returns after this period or by pressing the CLOSE button.

RUN PATTERN

This option initiates the recorded pattern. To exit the menu or stop running, move the Joystick.

RETURN Return to Main Menu.

PAL CAMERA

No sub-menu option for this.

MAIN MENU

1. DISPLAY SETUP
2. CAMERA SETUP
3. CONTROL SETUP
4. PROGRAM
- 5. PAL CAMERA**
6. CAM DEFAULT SET
7. RESET PT
8. EXIT

PAL / NTSC CAMERA

To switch from PAL to NTSC camera use the Joystick pan left or pan right. Note that PAL is the UK standard. Press the CLOSE button to exit or move down using the up and down toggle to move to the EXIT point.

CAM DEFAULT SET

No sub-menu option for this.

MAIN MENU

1. DISPLAY SETUP
2. CAMERA SETUP
3. CONTROL SETUP
4. PROGRAM
5. PAL CAMERA
- 6. CAM DEFAULT SET**
7. RESET PT
8. EXIT

CAM DEFAULT SET

This option sets the camera default settings. Press the CLOSE button to exit or move down using the up and down toggle to move to the EXIT point.

RESET PT

MAIN MENU

1. DISPLAY SETUP
2. CAMERA SETUP
3. CONTROL SETUP
4. PROGRAM
5. PAL CAMERA
6. CAM DEFAULT SET
- 7. RESET PT**
9. EXIT

RESET PT

This option resets the PTZ905 settings. The following display will be output 

Use the Joystick left or right pan to toggle between YES and NO. Press the CLOSE button to initiate the required option.

THE OPERATION WILL
CLEAR ALL TITLES
DO YOU WANT TO
CONTINUE ?

YES NO

EXIT

MAIN MENU

1. DISPLAY SETUP
2. CAMERA SETUP
3. CONTROL SETUP
4. PROGRAM
5. PAL CAMERA
6. CAM DEFAULT SET
7. RESET PT
- 8. EXIT**

Use the Joystick to select the option and press the CLOSE button to exit menu.

Controlling one camera then another.

If you look at the image of the LCD display you can see the CAM=001 indicates that the keyboard is ready to talk to camera address 1. In the PTZ905 the address 1 is set as default in the factory. You need to alter the DIP-switches within the PTZs to address 2, 3 etc if you have multiple PTZs on the same site, refer to the previous instructions how to set the DIP Switches. If you have another PTZ set at camera address 2, press 2 followed by CAM. This would change the screen to CAM=002. And so on.

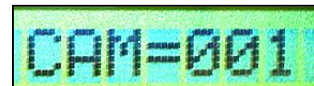

with

Installation Instructions

Product Dimensions

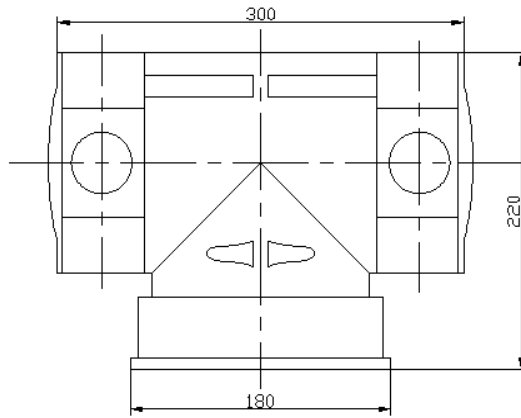

Outline Sizes of the PTZ905

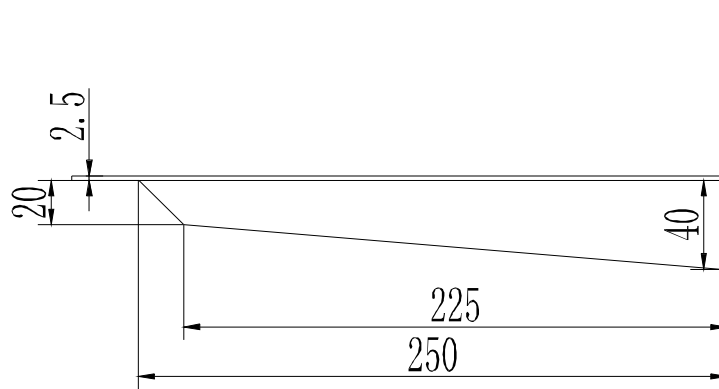

Side Elevation

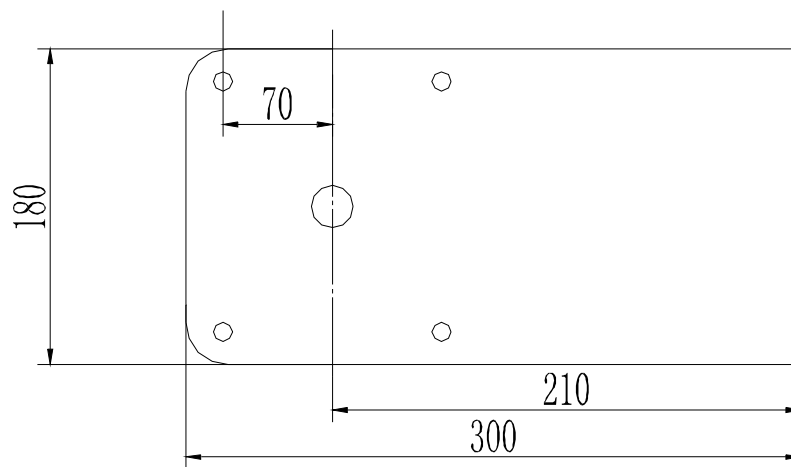

End Elevation

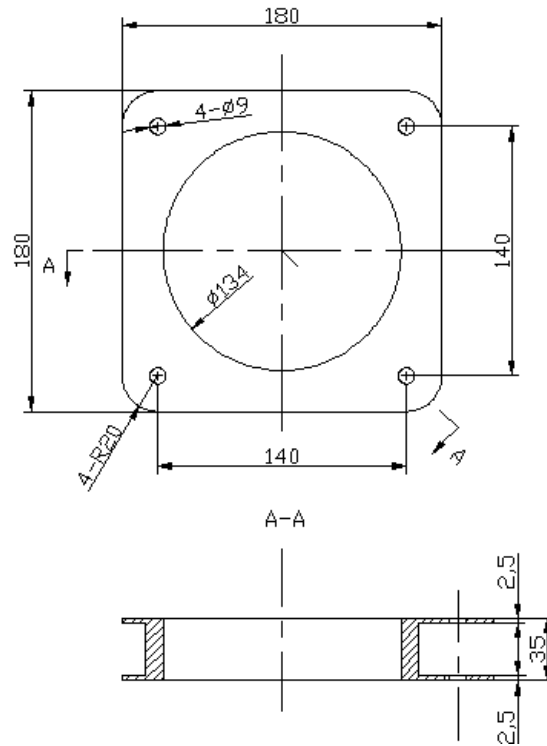

Shock Absorber sizes

Installation Steps

1. Remove the bottom plate of the pan/tilt.
2. In accordance with the instructions detailed earlier in this manual set the address, protocol, baud rate and termination jumper.
3. Install the bottom plate of the pan/tilt and ensure that the waterproof seal is carefully located ensuring a good seal.

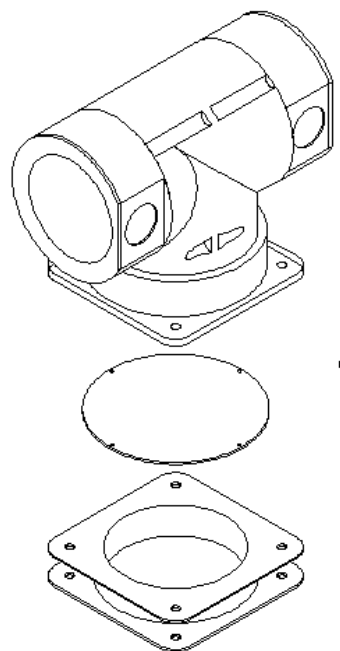

4. Connect the output wires of the socket according to relative colours on the schematic drawing. Ensure that the correct cables are used.

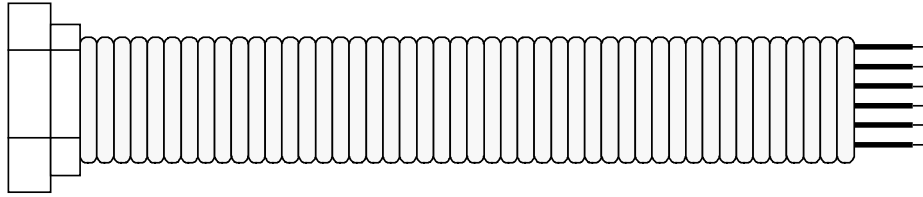

Attention: refer to power label

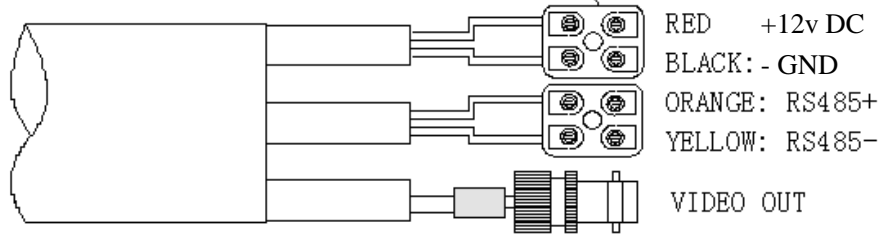

5. On the PTZ905 only the 7-core socket is used and the 10-core socket is disabled so that there is no alarm input connections.

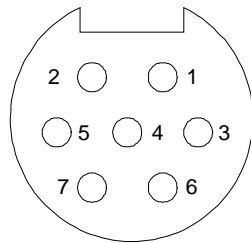

7 CORE TERMINAL

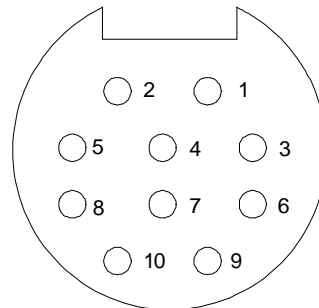

10 CORE TERMINAL NOT USED

PIN 1	DC12V	RED
PIN 2	GND	BLACK
PIN 3	RS485 -	YELLOW
PIN 4	NOT USED	
PIN 5	RS485 +	ORANGE
PIN 6	VIDEO +	
PIN 7	VIDEO -	

VI. Technical data table

Specifications	Image Inductor	Depends on camera type fitted
	Pixels	Depends on camera type fitted
	In-Phase System	In-Phase Inside
	Video Output	1.0 Vp-p/75 Ω
	White Balance	Auto / Manual
	Power Supply	12V DC \pm 10% 3A
	Power Consumption	30 VA
	Weight	10Kg
	Operating Temperature	-35°C ~ 55°C
	Waterproof Class	IP66
	Installation	Internal/External
	Signal /Noise Ratio	\geq 50db
	Relative Humidity	10~90%
	Dome Function	Pan Movement
Tilt Movement		0~60°/s
Scanning Speed		0.5~30°/s
Preset		128 presets (max)
Auto Cruise		At best 6 cruises
Pattern		40 sec.
Infrared Lamps	Infrared LEDs	40 LEDs
	Wavelength	850nm
	Projection Distance	30 metres
	Power Consumption	1.6 watts
	Infrared Control	Auto/Manual control via menu

Appendix A: Lightning Proof and Surge Signal Proof

This product adopts TVS lightning proof technology to prevent damage by a lightning strike below 1500 W and surge impulse signals. However it is also necessary to ensure that the following precautions are taken to ensure electrical safety:

- I Keep the communication cables at least 50 meters away from high voltage equipment or cables.
- I Where possible locate outdoor cables under eaves to provide best protection.
- I In an open area run cables in steel tubing and attach a single point ground to the tube.
- I In areas prone to thunderstorms or high EMF (such as a high voltage transformer substation), additional lightning proof equipment must be installed.
- I Always design the installation taking account of the building lightning proof requirements and grounding of outdoor equipment in accordance with the national and industrial standards.
- I The system must be grounded with equal potentials. The earth ground connection must satisfy anti-interference and electrical safety requirements and must not short circuit the high voltage electricity network. When the system is grounded separately, the resistance of the down conductor should be $\leq 4 \Omega$ and the sectional size of the down conductor should be $\leq 25\text{mm}^2$ (refer to Fig 36).

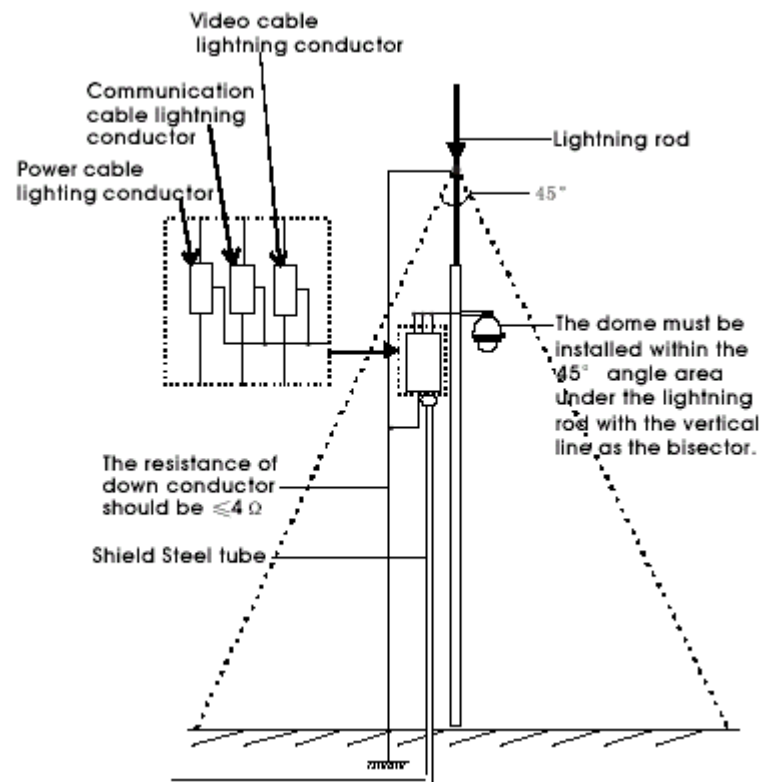

Figure 36

NOTE: This technology HELPS prevent the PTZ from being damaged by lightning strikes but under no circumstances does it guarantee protection. PTZs struck by lightning will not be covered by the warranty.